

E21171

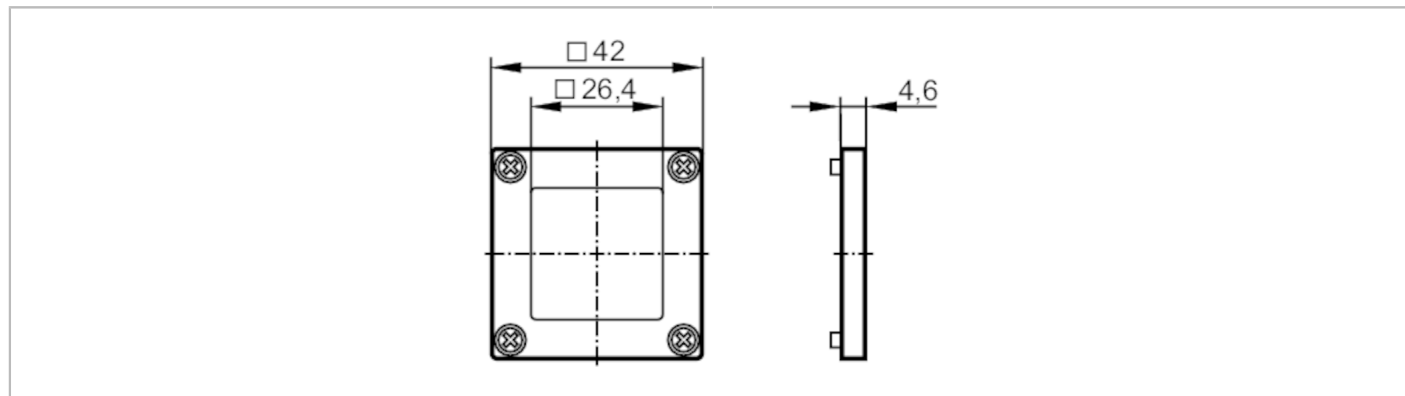

Protective cover

MASKING FRAME FOR O1D GLAS



Mechanical data	
Weight [g]	39.3
Dimensions [mm]	42 x 4.6 x 42
Materials	bezel: diecast zinc finish black; front lens: glass transparent and uncoloured; Sealing: FPM 75 ±5 Shore A; screws: stainless steel
Tightening torque [Nm]	0.6; (screws)
Accessories	
Accessories (supplied)	screws: 4 x (M3 x 8)
Remarks	
Remarks	By attaching the protective cover the measured distance value can be changed by up to +5 mm. This deviation influences the specified accuracy. The repeatability remains unchanged. By soiling or scratching the window the repeatability and accuracy of the sensor can deteriorate.
Pack quantity	1 pcs.