

ASSEMBLY

SECTION A-A

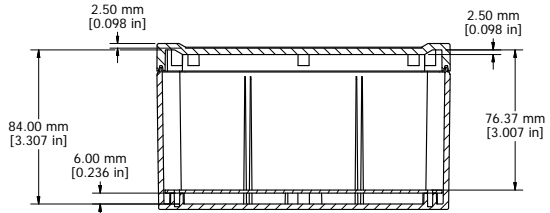

SECTION B-B

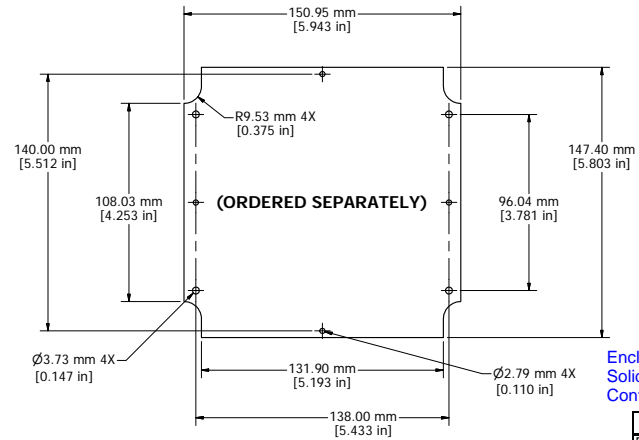

STEEL INNER PANEL

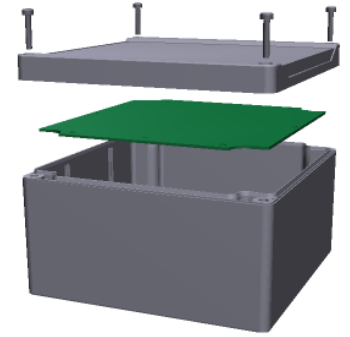

Polycarbonate Version Only  
**UL US LISTED**  
 File #E65324  
 NEMA 4, 4X

Enclosures can be Factory Modified ( Milling, Drilling, Printing etc. )  
 Solid models of this enclosure available in STEP or IGES.  
 Contact Factory [mjm@hammondmfg.com](mailto:mjm@hammondmfg.com)

**NOTE**  
 Purchased assembly includes box, styled lid, 4 cover screws, and preformed silicone gasket.  
 General Purpose ABS version is not UL approved. (Matl UL94 - HB)  
 Polycarbonate version is UL 508 approved. (Matl UL94 - V0)

**Recommended Cover screw torque -- 2.5 lbf-in (30 cN-m)**

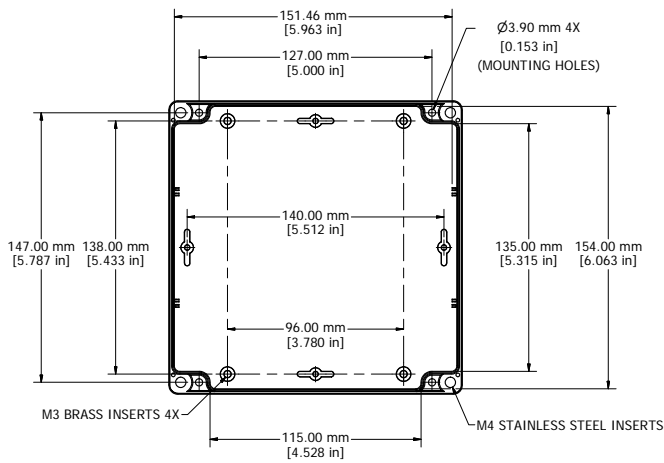

BOX - INSIDE

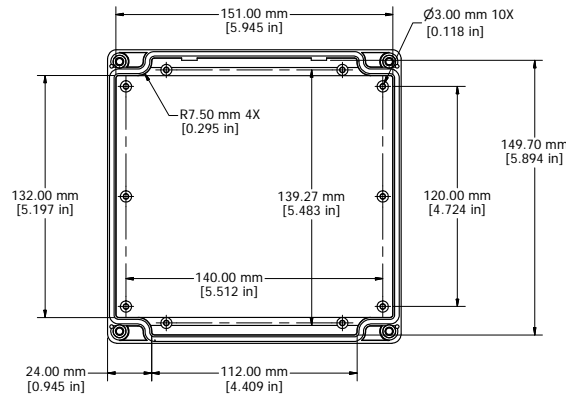

LID - INSIDE

1555S	
1555S Regular Enclosure	
General Purpose ABS RAL-7035	1555SGY
Polycarbonate RAL-7035	15552GY
ACCESSORIES	
Steel Inner Panels	1554RPL
Steel Panel / P.C. Board Machine Screw [M3 x 8mm Plated]	1591MM100
Steel Panel / P.C. Board Self Tapping Screw [#6 X 1/4" (6.4mm) Plated]	1598ATS100
Cover Screws (Pkg 4) [M4 X 20mm Stainless Steel]	SC1554

**HAMMOND MANUFACTURING™**  
 1555S  
[www.hammondmfg.com](http://www.hammondmfg.com)