

DESCRIPTION

The MP3336A is a compact, dual-channel, high-power, flash LED driver that can drive up to 2A in flash mode for each LED. It is usually applied for camera phones to improve image and video quality in low-light environments. The MP3336A operates with a selectable 1/2/3/4MHz switching frequency and uses a synchronous, current-mode PWM boost converter to regulate the LED current with two high-current sources. The MP3336A provides a high efficiency and optimized solution for smaller PCB spaces.

The MP3336A features a standard I²C interface, dual LED channels, rich protection modes, and high power density and performances. The MP3336A can also support flash, assist, indicator, and 5V DC modes.

The cathodes of the dual-flash LED are referenced to GND, which is better for improving thermal performance in layout. The MP3336A is available in a WLCSP-20 (1.6mmx2.0mm) package.

ELECTRICAL SPECIFICATION

Parameter	Symbol	Value	Units
Input Voltage	V _{IN}	2.7-5.5	V
Output Voltage	V _{OUT}	<5.5	V
LEDs #		2	
LED Current/string	I _{LED}	Max.2	A

FEATURES

- 2.7V~5.5V Input Voltage
- 1/2/3/4MHz Selectable Max Fsw
- Fsw Fold-back Function
- 400kHz I²C Compatible Interface
- Standby/Flash/Assist/Indicator/5V DC Modes

Flash Mode

- Up to 2A/Ch Programmable Current with ±7% Accuracy for Each LED, 7.84mA/Step

Assist Mode

- Up to 319mA/Ch Programmable Current with ±7% Accuracy for Each LED, 1.25mA/Step

Indicator Mode

- Works in 31.5kHz PWM Dimming Mode with 2/16, 3/16, 4/16, 5/16 Duty Cycle
- Used for Blinking and 128/256/512ms Selectable Blinking Time

5V DC Mode

- Output Constant 5V DC Voltage
- Separated EN1 Pin for NFC Application
- 1A to 4.2A Programmable Input DC Current Limit Protection
- External Strobe/TX Pin
- VIN to VOUT Disconnection Function
- Low-Battery Voltage Protection
- LED Short/Open Protection
- VOUT-GND Short Protection
- Over-Voltage Protection (OVP)
- Over-Temperature Protection (OTP)
- Input Under-Voltage Lockout (UVLO) Protection
- WLCSP-20 (1.6mmx2.0mm) Package

APPLICATIONS

- Smartphone Flash LED Application
- Cameras for Tablets
- Digital Still Camera

All MPS parts are lead-free, halogen free, and adhere to the RoHS directive. For MPS green status, please visit MPS website under Quality Assurance. "MPS" and "The Future of Analog IC Technology" are Registered Trademarks of Monolithic Power Systems, Inc.

EV3336A-C-00A EVALUATION BOARD



(L x W) 5.5cm x 5.5cm

Board Number	MPS IC Number
EV3336A-C-00A	MP3336AGC

EVALUATION BOARD SCHEMATIC

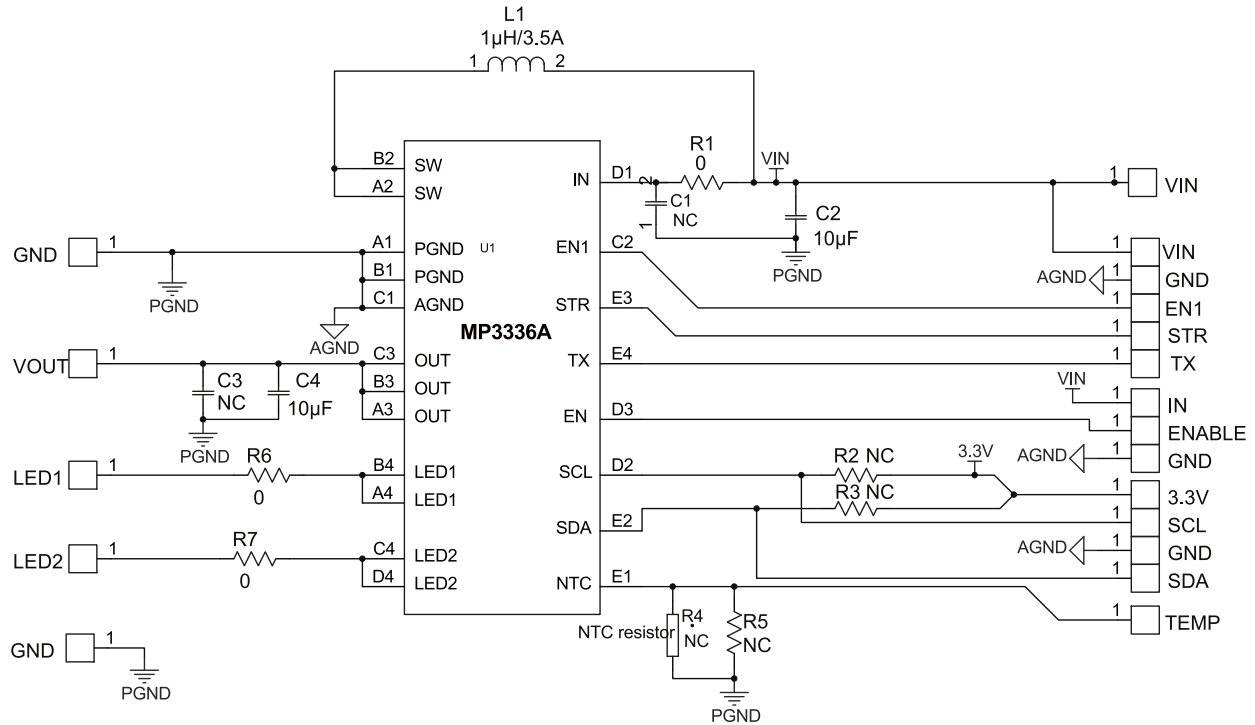
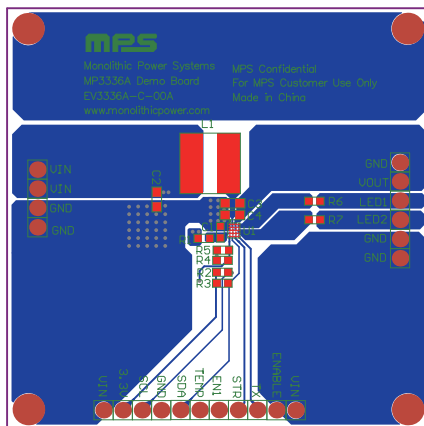
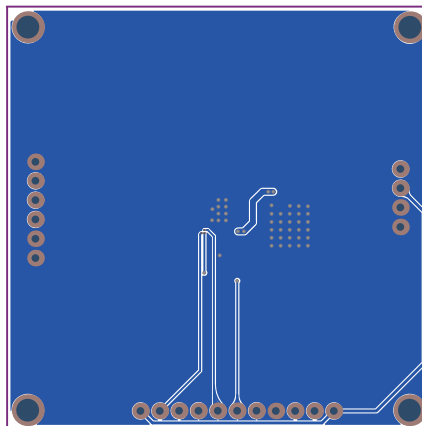

Figure 1: Dual-Channel Application Circuit

EV3336A-C-00A BILL OF MATERIALS

Qty	Ref	Value	Description	Package	Manufacturer	Manufacturer PN
1	C1	NC		0603		
2	C2,C4	10uF	Ceramic Capacitor,10V,X5R	0805	muRata	GRM21BR61A106KE19L
1	C3	NC		0805		
3	R1,R6,R7	0	res,1%	0603	Yageo	RC0603FR-070RL
4	R2,R3,R4,R5	NC		0603		
1	L1	1.1uH	1.1uA, 20m, 3.46A		TDK	D53LC-#A915AY-1R1M
1	U1		MP3336A	CSP9 2.01*1.61mm	MPS	MP3336A

PRINTED CIRCUIT BOARD LAY**Figure 1: Top Layer****Figure 2: Bottom Lay**

QUICK START GUIDE

1. Connect the positive and negative terminals of the power supply (2.7V ~5.5V) to the VIN and GND pins on the EV board, respectively.
2. Supply the EN terminal with logical signal.
3. Connect the positive and negative terminals of the LED to the LED1/2 pin and GND on the EV board, respectively.
4. Please connect SCL, SDA and GND of EV board to the SCL, SDA and GND of a programmable kit (EVKT-USBI2C-02) with I2C interface, respectively.
5. Power on sequence: VIN → EN → I2C setting → Set LED1/2_EN bit (to light the LED load). When work in flash mode with hardware trigger mode, please give a level or pulse signal to STR pin.

NOTICE: The information in this document is subject to change without notice. Users should warrant and guarantee that third party Intellectual Property rights are not infringed upon when integrating MPS products into any application. MPS will not assume any legal responsibility for any said applications.