

E21216

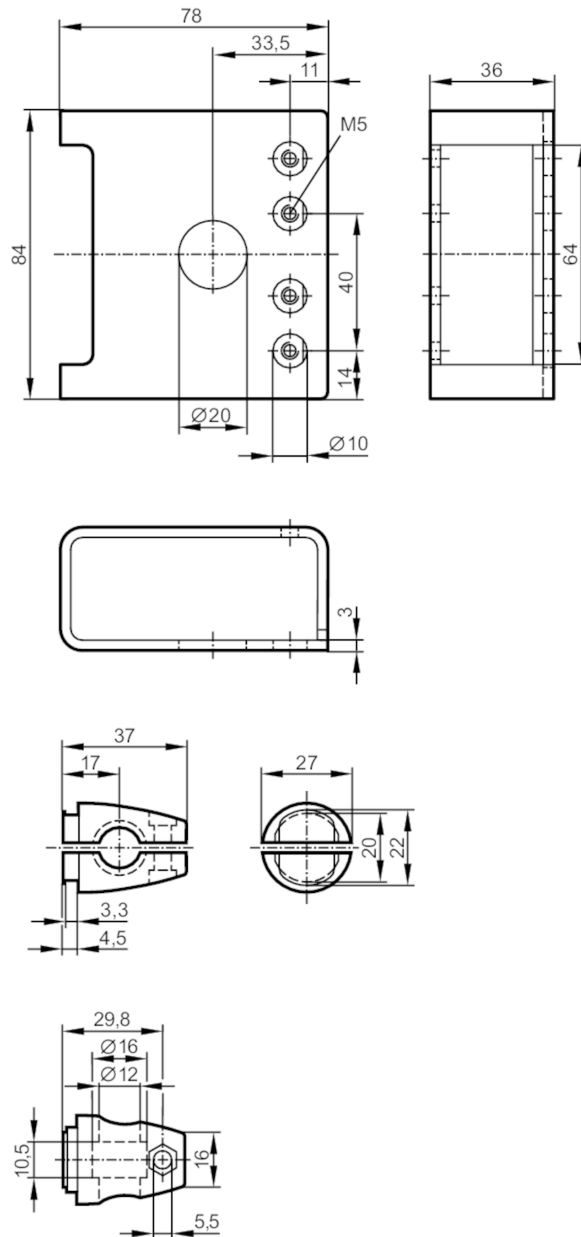

Mounting set with protective cover for photoelectric sensors

O4 PROTECTIVE BRACKET 500



Application	
Design	clamp mounting, with protective cover
Mechanical data	
Weight [g]	384
Type of mounting	Mounting rod; (Ø 12 mm)
Materials	stainless steel (1.4404 / 316L); Clamp: stainless steel
Accessories	
Accessories (supplied)	head cap screw: 1 x M5 x 16 cylinder screws: 2 x M5 x 30
Remarks	
Pack quantity	1 pcs.