

DESCRIPTION

300 Series

The **300 SERIES** is a range of diaphragm valve suitable for Dust collector applications, in particular for reverse pulse jet filter cleaning of filter bags, cartridges, envelope filters, ceramic filters and sintered metal fibre filters. The 300 Series valve has the inlet port at 90° to the outlet port. These valves allow a very quick connection, by fitting directly to unthreaded pipes. These valves are available in three models: 3/4", 1", 1 1/2". The 1 1/2" model is available in the single and double diaphragm version. The valves are constructed in die-cast aluminium and have an anodised protection treatment which protects them from corrosive and environmental agents. Bolts and screws are in stainless steel. The 300 Series is available in the following versions:

- VNP, with integrated solenoid pilot
- VEM, with remote pneumatic connection.

Important: The installation of these valves should only be for pneumatic connection and not for mechanical fixing. We suggest that the pipe should butt up to the internal lip of the valve.

Upon request: Integral pilot valves with ATEX Certification: • ATEX II 3 D (94/9/CE) for the above approved model the correct code to use is VEM+PV 24V/DCX (solenoid coil is 24V-DC/12W and Din connector in conformity to the ATEX Directive 94/9/CE) (PLG9-ATEX). Remote pilot valves meet the requirements of: • ATEX II 2 GD when mounted with PXA Pilot or CXD Enclosure (94/9/CE).

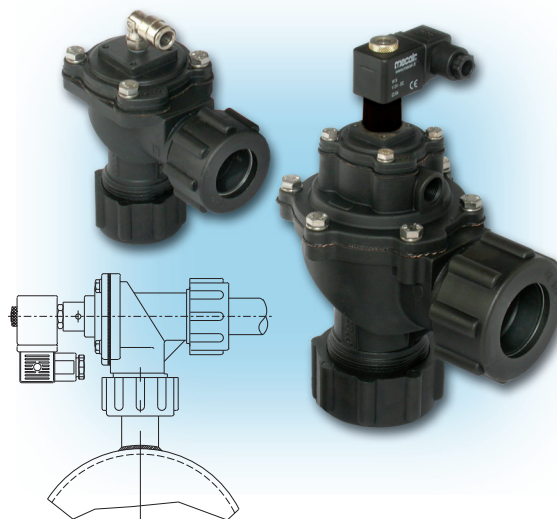

GENERAL CHARACTERISTICS

Fluids	Filtered air and oil free
Diaphragm	Standard NBR: -20°C / +120°C
	Optional Viton: -30°C / +200°C
	Nitrile: -40°C / +120°C
Pressure range	From 0,5 to 7,5 bar

CONSTRUCTIVE FEATURES - VALVE

Cover	Die-cast aluminium (Anodised)
Body	Die-cast aluminium (Anodised)
Pilot Base	Brass (Chromed)
Pilot	Stainless Steel
Diaphragm	NBR
Bolts and screws	Stainless steel
Diaphragm Backing disk	Stainless steel
Diaphragm spring	Stainless steel

ELECTRICAL CHARACTERISTICS - SOLENOID

Coil insulation	Class H
Din Socket Connector	Pg9 Connection
Din Socket Standard	EN175301 - 803 / A/ISO 4400
Din Socket Optional	94/9/CE ATEX II 3GD T6
Isolation class Din socket	VDE 0110 - 1/89
Electrical protection	IP65 EN60529
Voltage Range	12V DC (-5%, +20%) 12W
	24V DC (-5%, +20%) 12W
	48 V DC (-10%, +20%) 9W
	110 V DC (-10%, +20%) 12W
	24V 50/60Hz (-10%, +20%) 16/12 VA
	48 V 50/60 Hz (-10%, +20%) 16/12 VA
	110/127 V 50/60 Hz (-10%, +20%) 19/14 VA
	220/240 V 50/60 Hz (-10%, +20%) 19/14 VA
Ambient temperature	-20°C / +60°C

TYPE	Port size Ø	N° Diaph.	Pressure range (bar)		Weight Kg.	Coil	Kv	Cv
			min.	max				
VNP306	3/4"	1	0,5	7,5	0,9	YES	10	11,6
VNP308	1"	1	0,5	7,5	1,2	YES	21	24,4
VNP312	1 1/2"	1	0,5	7,5	2,2	YES	37	43,0
VNP314	1 1/2"	2	0,5	7,5	2,3	YES	47	54,6
VEM306	3/4"	1	0,5	7,5	0,6	NO	10	11,6
VEM308	1"	1	0,5	7,5	0,9	NO	21	24,4
VEM312*	1 1/2"	1	0,5	7,5	1,9	NO	37	43,0
VEM314	1 1/2"	2	0,5	7,5	2	NO	47	54,6

HOW TO ORDER:

VEM/VNP 3 06 110/50

VNP: with integral pilot
VEM: without pilot

3: "300 SERIES"

VALVE CONNECTION DIAMETER:

- 06 = 3/4"
- 08 = 1"
- 12 = 1 1/2" (single diaphragm)
- 14 = 1 1/2" (double diaphragm)

Voltage and frequency required.

DIMENSIONS

300 Series

VNP 306 - 308 - 312

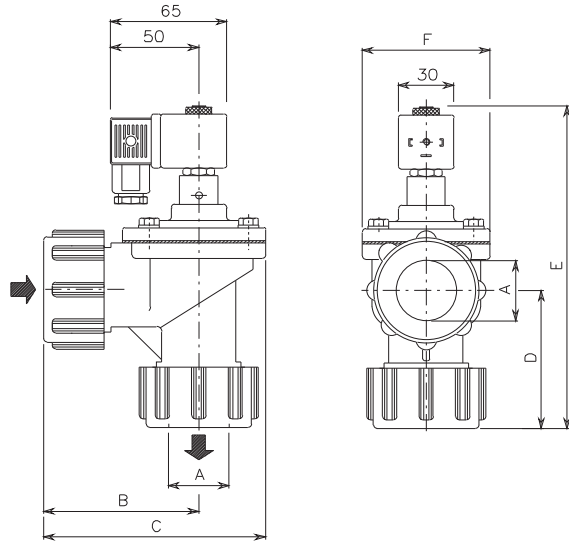

VEM 306 - 308 - 312

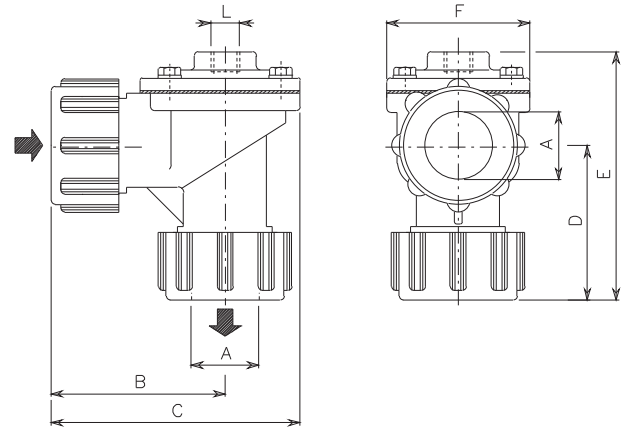

VNP 314

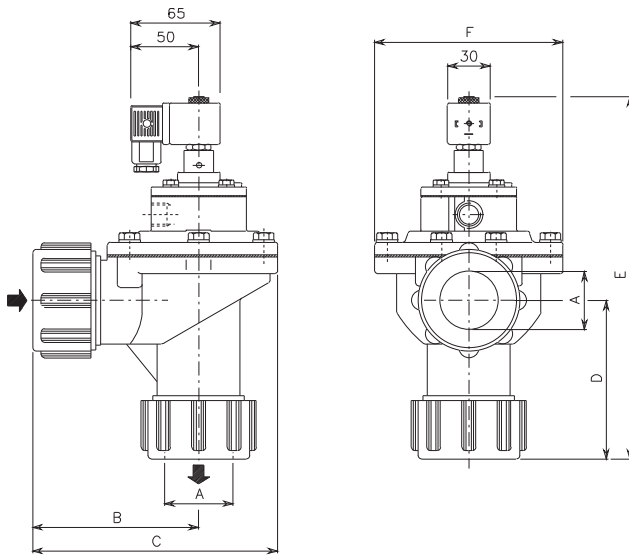

VEM 314

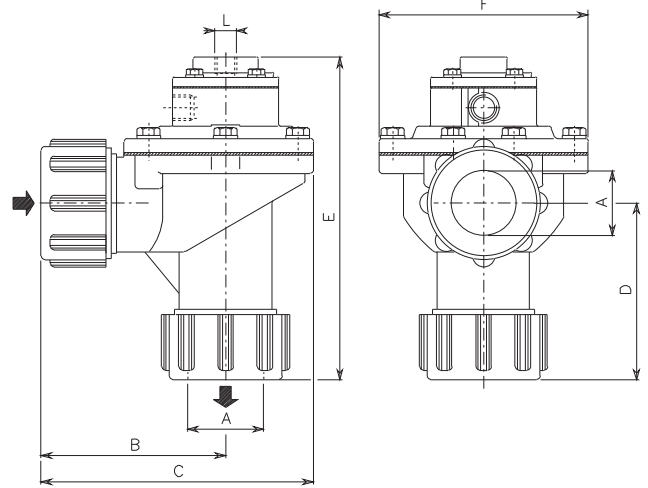

MODEL	Ø A	B	C	D	E	F	Weight Kg.	MODEL	E	Ø L	Weight Kg.	Pressure range (bar)		Diaph. N°
												min	max	
VNP 306	3/4"	77	108	67	167	60	0,90	VEM 306	107	1/4"	0,60	0,5	7,5	1
VNP 308	1"	90	128	80	183	74	1,20	VEM 308	123	1/4"	0,90	0,5	7,5	1
VNP 312	1 1/2"	114	176	99	220	135	2,20	VEM 312	160	1/4"	1,90	0,5	7,5	1
VNP 314	1 1/2"	114	176	99	252	135	2,30	VEM 314	192	1/4"	2	0,5	7,5	2

SPARE PARTS

300 Series

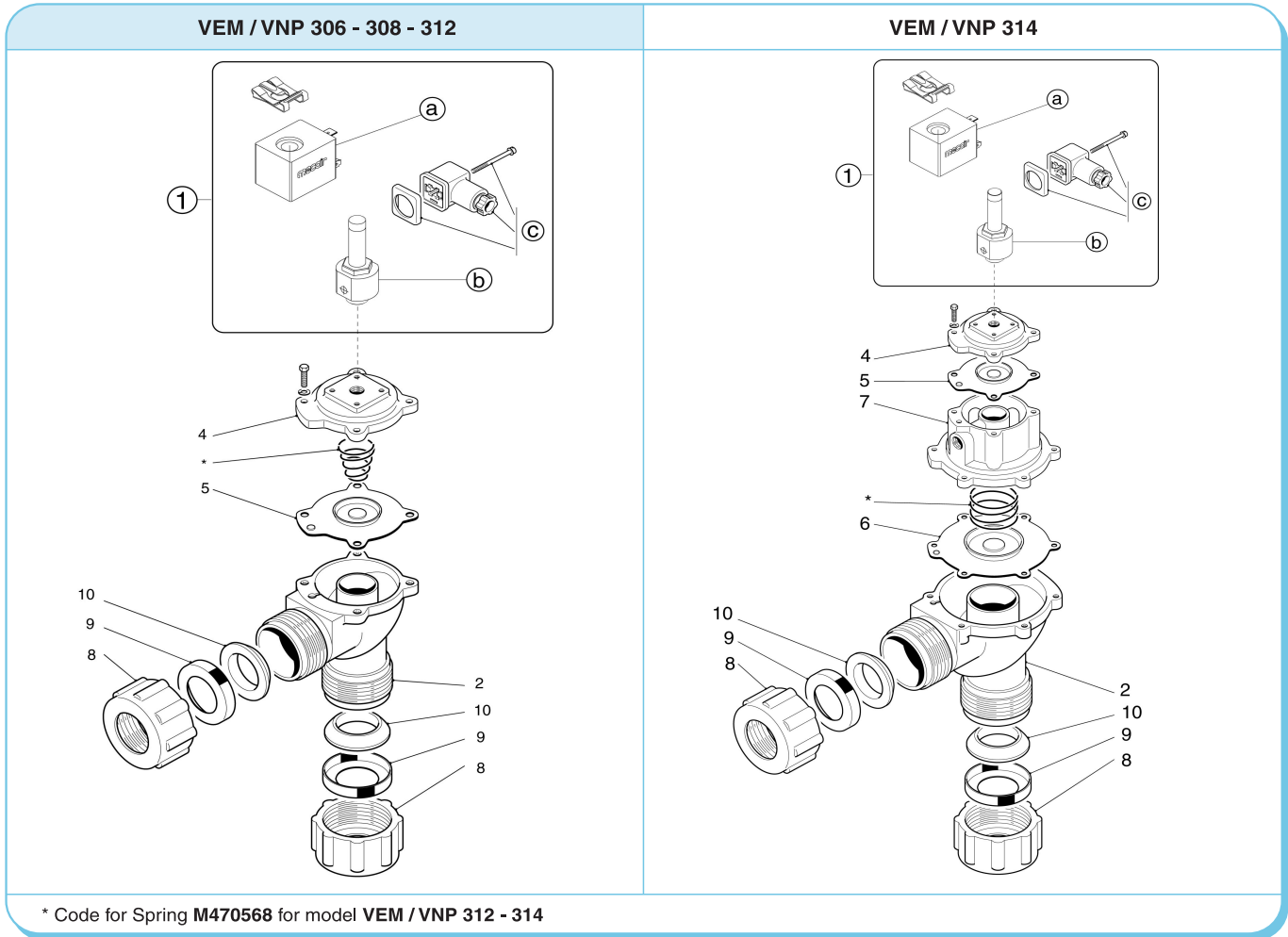

* Code for Spring **M470568** for model **VEM / VNP 312 - 314**

STANDARD Version

POS	DESCRIPTION	CODE
1	a) Solenoid (*)	a) SB3 - ../.. (*)
	b) Pilot group complete with base and ferrule	b) CP1/4
	c) Din Connector PG9EN175301-803 IP65	c) PLG9

(*) Specify Voltage and Frequency

OPTIONAL Version

POS	DESCRIPTION	CODE
1	a) Solenoid	a) SB3 - 24/DCX
	b) Pilot group complete with base and ferrule	b) CP1/4
	c) Din Connector (3GD IP65 T6)	c) PLG9 - ATEX

Version in conformity to European Directive 94/9/CE ATEX (cod. PV-24/DCX)

POS	DESCRIPTION	CODE			
		VEM/VNP306	VEM/VNP308	VEM/VNP312	VEM/VNP314
1	Pilot group complete with solenoid(*) and din connector	PV - ../.. (*)	PV - ../.. (*)	PV - ../.. (*)	PV - ../.. (*)
1+4	Pilot group complete with solenoid(*) and din connector, top cover and screws	PVM06 - ../.. (*)	PVM08 - ../.. (*)	PVM12 - ../.. (*)	PVM06 - ../.. (*)
2	Valve Body	M300203	M300206	M300213	M300213
7	Intermediate cover (Double diaphragm)	-	-	-	M310098
4	Top Cover	M310082	M310086	M310092	M310082
5	Diaphragm	DB 16	DB 18	DB 112	DB 16
6	Diaphragm (Secondary)	-	-	-	DB 114
8	Dresser Nut	M550022	M550024	M550026	M550026
9	Dress nut insert	M620013	M620014	M620015	M620015
10	Conic seal for dresser nut	M330202	M330203	M330204	M330204

(*) Specify Voltage and Frequency

INSTRUCTIONS AND MAINTENANCE

300 Series

1) - INSTALLATION INSTRUCTIONS

VALVE INLET: Mount valve inlet to tank stub pipe and ensure correctly connected. Valve reference "IN".

VALVE OUTLET: To be connected to blowpipe within the filter. Valve reference "OUT".

SEALING OF BLOWPIPE:

Suited to an unthreaded blowpipe only - The blowpipe must enter into the valve body and secured with the dresser nut.

FLUID:

COMPRESSED AIR - Ensure air supply is clean and dry. (We recommend the installation of compressed air filter units to be installed directly before the pressure vessel, in order to ensure clean and dry is supplied to the diaphragm valve). Operating pressure min/max. 0.5 ÷ 7.5 bar.

AIR INLET PIPE TO HEADER TANK/PRESSURE VESSEL:

Minimum Ø 1" for tanks with a 3/4", 1" o da 1 1/2".

COMPRESSOR:

With the appropriate compressor size being utilised, this ensures the tank can be refilled from 0-2 bar in a few seconds.

PROTECTION FROM RAIN:

Always ensure a small roof/lid is installed on top of the valves and/or electronic controllers as this protects the valves and controllers from exposure to harsh environmental conditions.

ELECTRICAL ON TIMES AND PULSE TIMES:

Average pulse times range from 100ms - 250ms depending on size of the valves being used.

2) - START UP

Before commencing to pulse the valves and to pressurise the tank/pressure vessel, it is important to eliminate all particulate, including dirt, rust, metal shavings, and other types of particulate, which may eventually enter the piping. The draining of any condensation or liquid within the tank/pressure vessel is also important and should be performed prior to pressurising the system. The drain valve should always be installed and should be used prior to start up. Minimum Ø of the drain valve socket is 1/4". If during the start phase, there is insufficient air in the airline, and you are unable to adequately fill the tank/pressure vessel, (the valves may remain slightly open), it is necessary to close the air inlet valve to the tank, wait for the pressure to reach 6 ÷ 7 bar and then re-open the valve quickly. This will ensure that the tank fills quickly also providing significant pressure which ensures the valves remain properly closed.

3) - SPARE PART RECOMMENDATION

3.1 - FOR START UP - Minimum quantity of 5% of the supply (min. 1 piece).

- Pilot Group (pos.1), complete with pilot body, solenoid coil, din connector.

3.2 - FOR THE FIRST TWO YEARS OF OPERATION - Minimum quantity of 10% of the supply (min. 2 pieces).

- Pilot Group (pos.1), complete with pilot body, solenoid coil, din connector.

- Diaphragms (pos.5 and/or 6)

4) - MAINTENANCE AND REPAIRS

4.1 - COMMON PROCESS FOR ALL CONTROLS, MAINTENANCE AND REPAIRS TO BE CONDUCTED:

- Before conducting any maintenance activity on the system ensure that the components are fully isolated from pressure and power supplies
- Replacement or controls relating to diaphragms (pos.5), in reinstalling/re-positioning the diaphragm ensure that the diaphragm bleed is in the correct position lined up with the valve body position. The bleed should fit into the valve body eyelet.
- Secure the bolts on the top cover to the valve body without over tightening. We recommend the use of a torque wrench to properly secure the bolts: o 1,6 kgm for M6 (3/4" - 1"), 3,8 kgm for M8 (1 1/2") and 7 kgm for M10 (1" - 2 1/2" - 3").
- Substitution of or controls relating to the solenoid pilot: and Prior to removing the solenoid pilot, ensure power supply is disconnected. Remove carefully din socket and then remove solenoid coil.

4.2 - PERIODICAL MAINTENANCE - Annually check: Diaphragm and pilot inspection should be conducted annually:

- In the case of VNP/VXP models, check the integrity of the electrical connections and the din socket connection to be properly fixed to the solenoid coil.
- In the case of VEM models, check the integrity of all pneumatic connections including pneumatic piping and all pneumatic connections.

4.3 - MALFUNCTION / TROUBLE SHOOTING: - Proceed with controls and checks below:

DEFECT / FAULT	CONTROL / CHECKS
The valve does not open or vibrates	<ul style="list-style-type: none"> - Verify integrity of the solenoid or that the wires are not damaged - Verify that the electrical connections are properly connected to the valve and that the wiring has been performed correctly - Verify that the outlets from the electronic controller are free from disturbances and within the specified tolerances of +/-10% of the nominal value
The valve remains opens or loses air continuously	<ul style="list-style-type: none"> - Check that the bolts of the top cover are properly secured, in case of diaphragm substitution - Remove the top cover and verify that there are no particulate underneath the diaphragm