



 GOYEN

DIAPHRAGM VALVES

3 SERIES

PULSE JET VALVES



FS3 Series



DD3 Series

T3 Series



DESCRIPTION

Superior performance, easy maintenance diaphragm valve available with threaded ports (T3), dresser nut ports (DD3) or flange and slide ports (FS3). Outlet at 90° to inlet. 3 Series valves are available as remote pilot valves and may be converted to integral pilot applications through the use of the screw in pilots of the MIP and 3DS series.

SUITABLE FOR

Dust collector applications, in particular for reverse pulse jet filter cleaning and its variations including bag filters, cartridge filters, envelope filters, ceramic filters, and sintered metal fibre filters.

CONSTRUCTION

Body: Aluminium (diecast)

Seals: Nitrile or Viton (diaphragms reinforced)

Spring: 304 SS

Diaphragm Seat: PA-6 (standard), Viton coated mild steel

OPERATION

Recommended

on time range: 50-500 ms

Recommended time

between pulses: 1 minute or greater

MAINTENANCE

Before conducting any maintenance activity on the system ensure that components are fully isolated from pressure and power supplies. Pressure and power should not be reapplied until the valve has been fully assembled.

Diaphragm and pilot inspection should be conducted annually.

APPROVALS

- Atex II 2D Mechanical (RCA Only)
- CSA (US) C22.2 No 139-1982, UL 429 (CA & RCA)

INSTALLATION

For your safety do not pressurise system until all valves and pipes are fully secured. Do not attempt to remove a fitted valve while system is under pressure.

1. Prepare supply and blowtube pipes* to suit valve type and specification. Avoid installing valves underneath the tank.

2. Ensure tank and pipes are free from dirt, rust or other particulate.
3. Ensure supply air is clean and dry.
4. Mount valves to inlet pipes (or flanges, tighten bolts to 10Nm) and blowtube to valves, ensuring no excess thread sealant can enter the valve itself. Ensure blowtube is fully inserted into the valve outlet.
5. Tanks and pipes must be independently restrained from FS and DD valves.
6. Connect RCAC pilot port to remote pilot valve, or install MIP/3DS screw in pilot valve.
7. Apply moderate pressure to system and check for installation leaks.
8. Fully pressurise system.
9. Test fire and listen for proper actuation and crisp pulse noise.

Valve is not a structural component. Do not rely on valve to retain tanks or pipe. Refer to Camlock product specifications for installation details.

*Pipes must be to Schedule 40 outside diameter

SCHEDULE 40 SIZE	OD MM	OD INCHES
¾"	26.7	1.050
1"	33.4	1.315

WEIGHTS

SIZE	REMOTE PILOT (RCAC) KG (LBS)	SIZE	REMOTE PILOT (RCAC) KG (LBS)
20T3	0.55 (1.21)	25T3	0.65 (1.43)
20ST3	0.55 (1.21)	25DD3	1.05 (2.32)
20DD3	0.55 (1.21)	25FS3	0.95 (2.08)
20FS3	0.55 (1.21)		

MAINTENANCE KITS AND ACCESSORIES

MODEL	NITRILE	VITON	INCLUDES
RCAC20T3, ST3, DD3, FS3 RCAC25T3, DD3, FS3, FH3	K2016 K2529	K2017 K2530	Diaphragm kits include main diaphragm, spring, and locking pin.
20DD3 Dresser nut seal kit	K2018	K2019	Nut, seal, and seal retaining ring.
25DD3 Dresser nut seal kit	K2533	K2534	Nut, seal, and seal retaining ring.
20FS3 Outlet seal replacement	G690338	G690338-2	Outlet seal
25FS3 Outlet seal replacement	G690763	G690763-2	Outlet seal
25FS3 Valve to baghouse wall seal	G690125	G690125-2	Wall seal
Camlock for 20 & 25FS3 and 6" round tank	K2514-2		Flange adaptor to mount FS valves to round tanks.
Camlock for 20 & 25FS3 and 8" round tank	K2536-2		Eliminates welding. Refer to Camlock product specification.

PRODUCT CHARACTERISTICS AND PERFORMANCE

MODEL	PORT SIZE		NUMBER OF DIAPHRAGMS	FLOW		PRESSURE RANGE KPA(PST)	TEMPERATURE RANGE °C (°F)	
	MM	IN		KV	CV		NITRILE SEALS	VITON SEALS
20T3	20	¾"	1	14	17	30(5)–860(125)	–40(–40) to 82(179.6)	–29(–20.2) to 232(449.6)
20ST3	20	¾"	1	14	17	30(5)–860(125)	–40(–40) to 82(179.6)	–29(–20.2) to 232(449.6)
20DD3	20	¾"	1	14	17	30(5)–860(125)	–40(–40) to 82(179.6)	–29(–20.2) to 232(449.6)
20FS3	20	¾"	1	19	22	30(5)–860(125)	–40(–40) to 82(179.6)	–29(–20.2) to 232(449.6)
25T3	25	1"	1	24	27	30(5)–860(125)	–40(–40) to 82(179.6)	–29(–20.2) to 232(449.6)
25DD3	25	1"	1	24	27	30(5)–860(125)	–40(–40) to 82(179.6)	–29(–20.2) to 232(449.6)
25FS3	25	1"	1	34	40	30(5)–860(125)	–40(–40) to 82(179.6)	–29(–20.2) to 232(449.6)

ORDER CODE

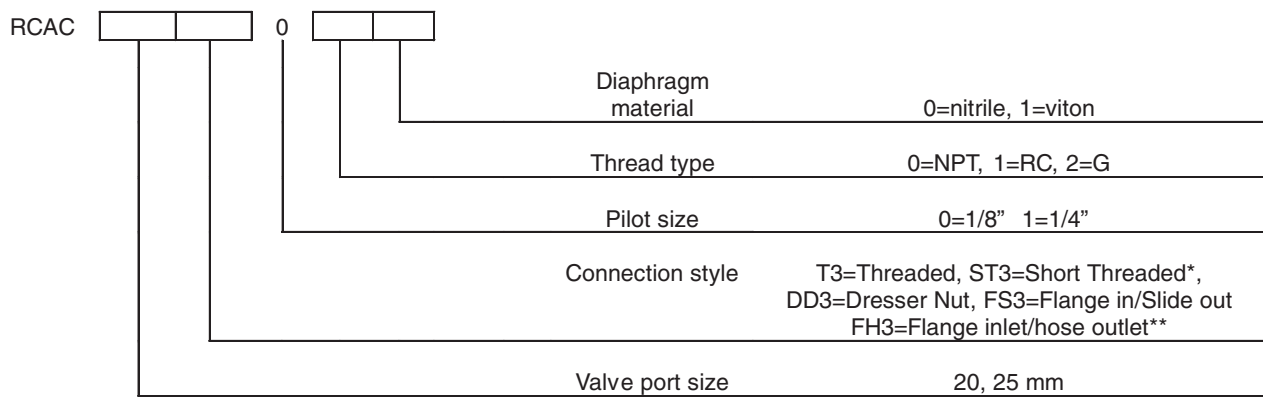

*Available for 20 [¾"] size only. **Available for 25 [1"] size only.

Examples: RCAC25T3010
 1" threaded port valve with 1/8" pilot, 1" RC port threads, nitrile seals.
 RCAC20FS3001
 ¾" flange inlet slide seal outlet port valve with 1/8" NPT remote pilot port and viton seals.

DIMENSIONS

(Dimensions in mm and [inches])

RCAC20T3

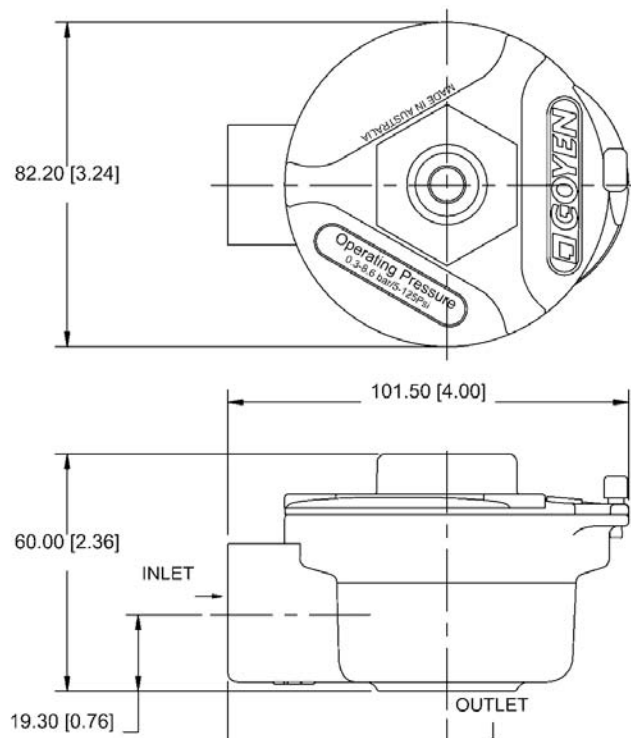
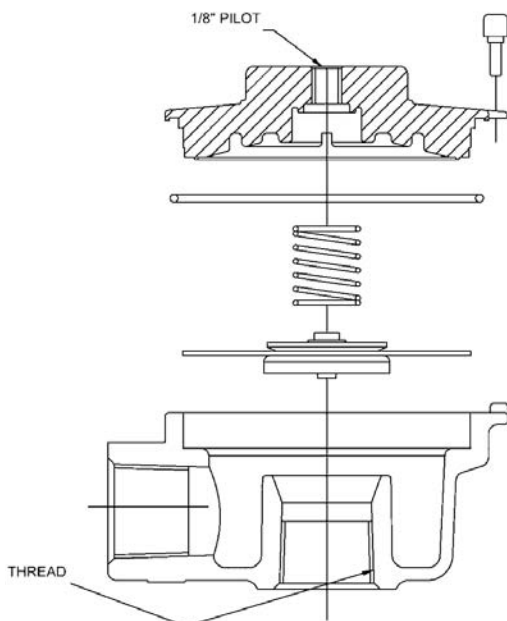

RCAC20ST3

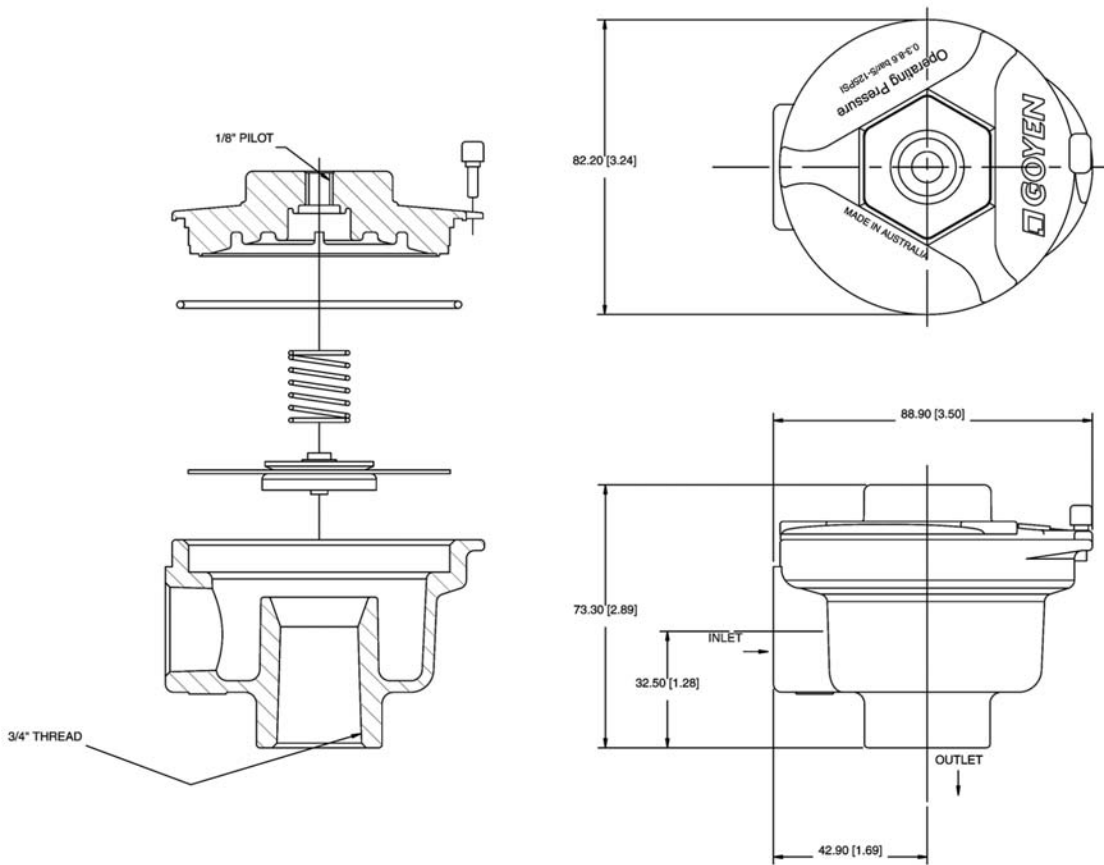

RCAC20DD3

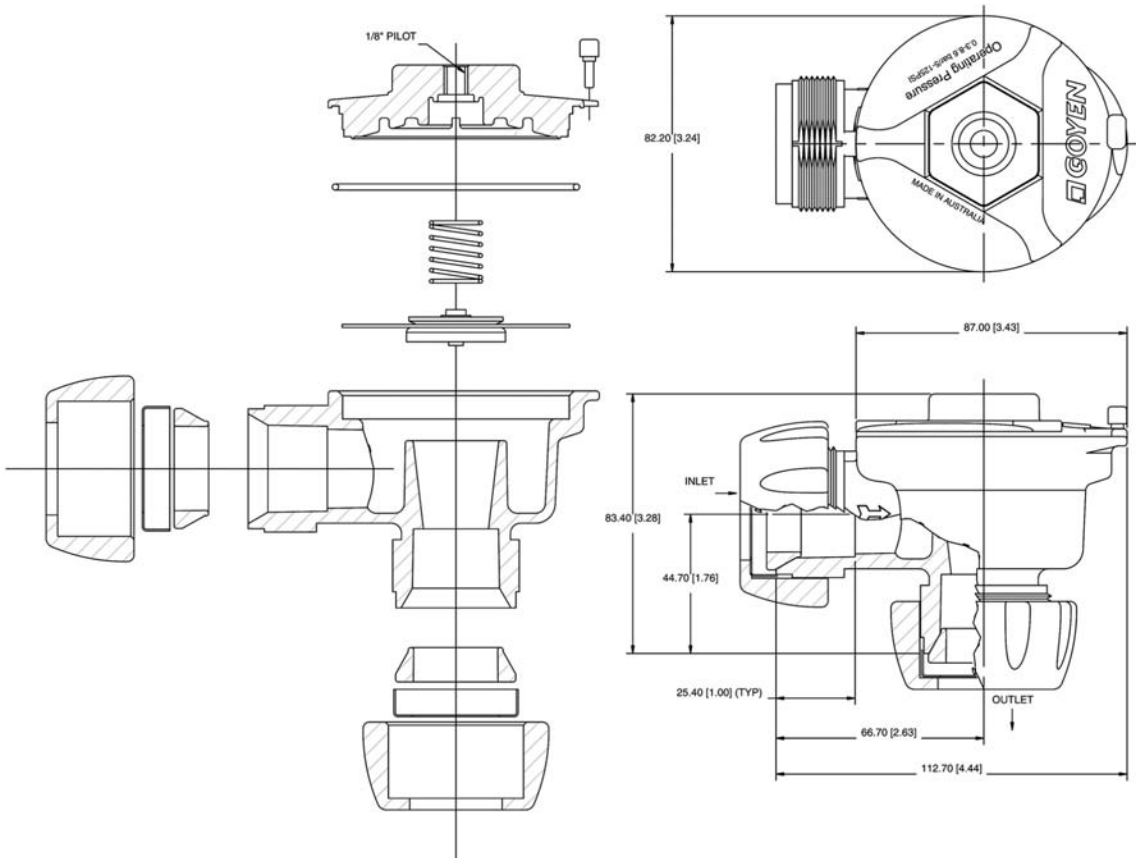

RCAC20FS3

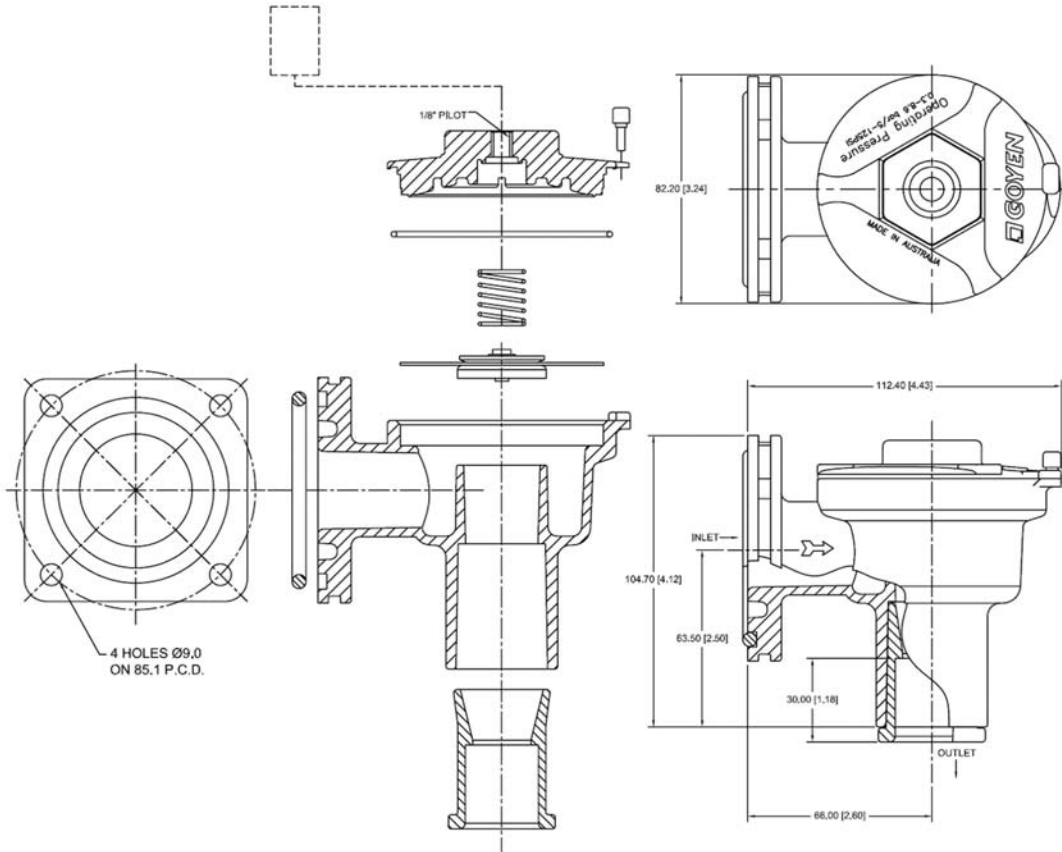

RCAC25T3

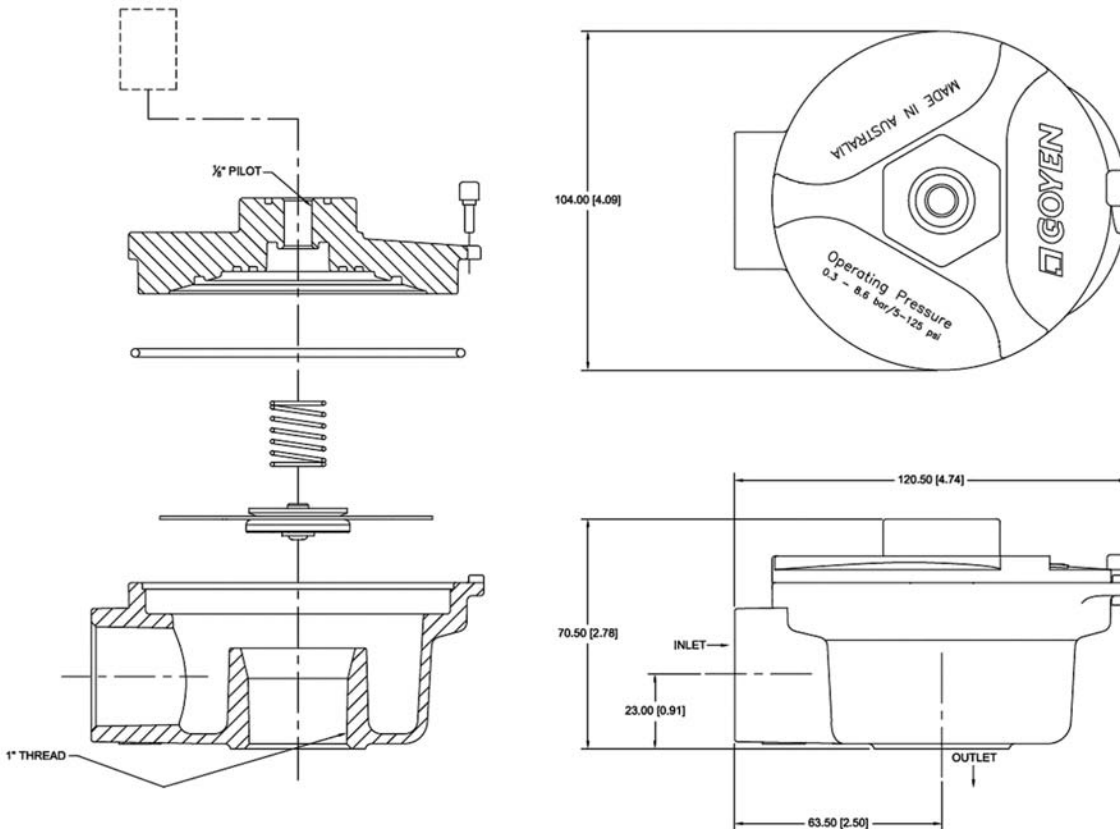

RCAC25DD3

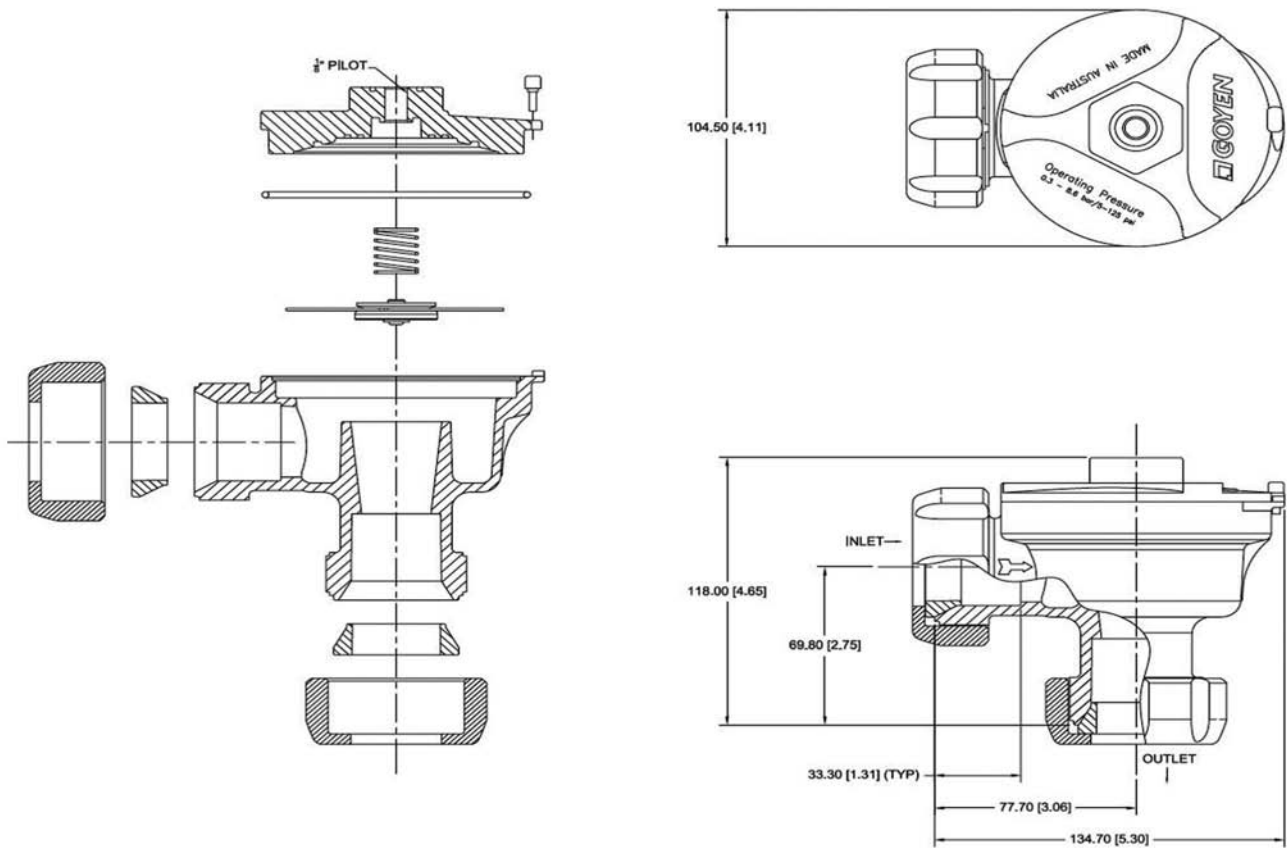

RCAC25FS3

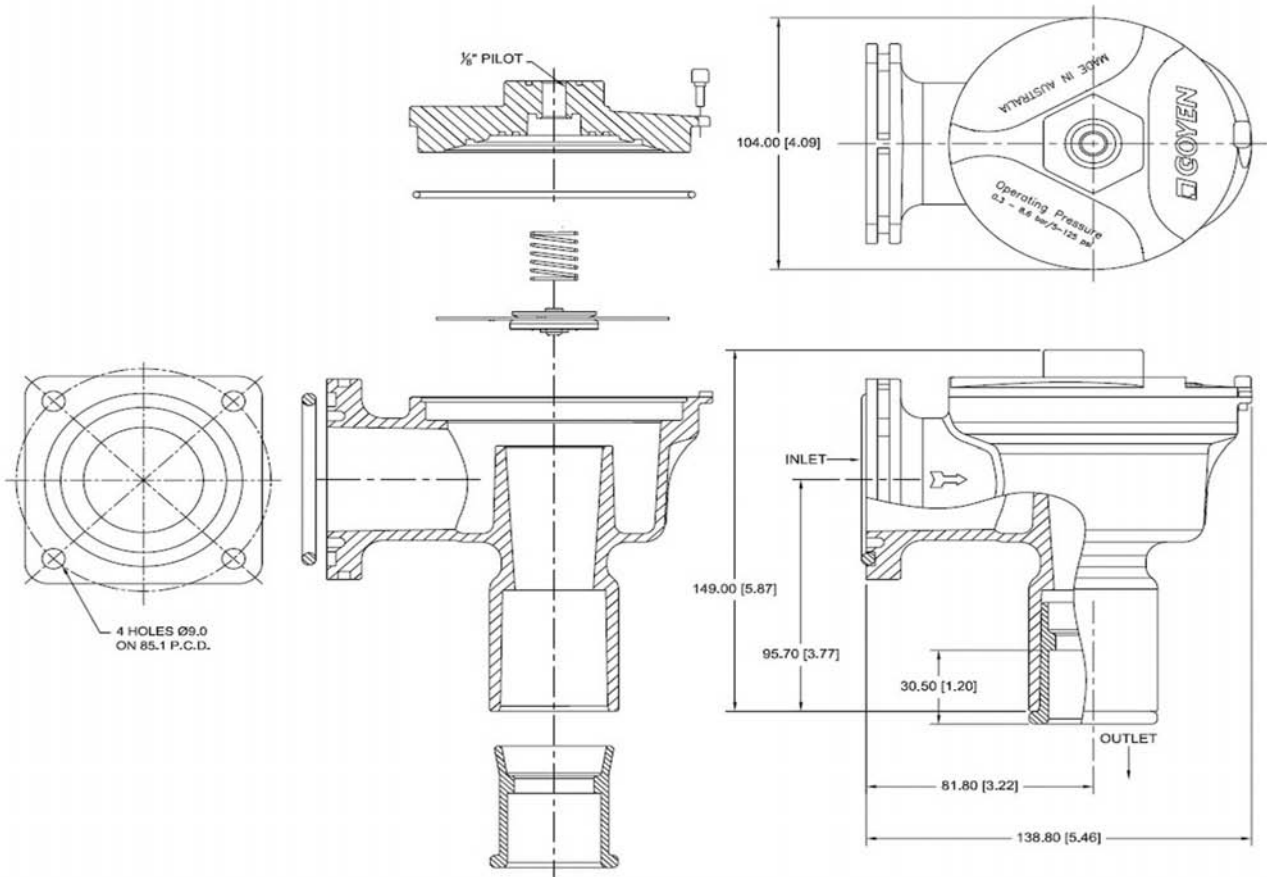

'T' SERIES

PULSE JET VALVES



T Series

DESCRIPTION

High performance diaphragm valve with threaded ports. Available with integral pilot or as remotely piloted valve. Outlet at 90° to inlet.

SUITABLE FOR

Dust collector applications, in particular for reverse pulse jet filter cleaning including bag filters, cartridge filters, envelope filters, ceramic filters, and sintered metal fibre filters.

CONSTRUCTION

Body: Aluminium (diecast)

Ferrule: 304 SS

Armature: 430FR SS

Seals: Nitrile or Viton (reinforced)

Spring: 304 SS

Screws: 302 SS

Diaphragm Seat: PA-6 (standard), Viton coated mild steel or High Density PE

Refer to Q Series Solenoid product data sheet for solenoid construction details.

OPERATION

Recommended

on time range: 50–500 ms

Recommended time

between pulses: 1 minute or greater

MAINTENANCE

Before conducting any maintenance activity on the system ensure that components are fully isolated from pressure and power supplies. Pressure and power should not be reapplied until the valve has been fully assembled.

Diaphragm and pilot inspection should be conducted annually.

APPROVALS

- Atex II 2D Mechanical
- CSA (U.S) C22.2 No 139–1982, UL 429 (CA & RCA)
- C-Tick (CA)
- EMC 2004/108/EC (CA)
- Low Voltage Directive 2006/95/EC (CA)

INSTALLATION

1. Prepare supply and blowtube pipes to suit valve specification. Avoid installing valves underneath the tank.
2. Ensure tank and pipes are free from dirt, rust or other particulate.
3. Ensure supply air is clean and dry.
4. Mount valves to inlet pipes and blowtube to valves, ensuring no excess thread sealant can enter the valve itself.
5. Make electrical connections to solenoid or connect RCA pilot port to pilot valve (RCA valves only).
6. Apply moderate pressure to system and check for installation leaks.
7. Fully pressurise system.
8. Test fire and listen for proper actuation and crisp pulse noise.

WEIGHTS

SIZE	INTEGRAL PILOT (CA) KG (LBS)	REMOTE PILOT (RCA) KG (LBS)	SIZE	INTEGRAL PILOT (CA) KG (LBS)	REMOTE PILOT (RCA) KG (LBS)
10	NA	0.06 (0.14)	45	1.50 (3.30)	1.28 (2.83)
20	0.60 (1.31)	0.38 (0.83)	50	2.89 (6.38)	2.68 (5.92)
25	0.73 (1.61)	0.51 (1.13)	62	3.31 (7.30)	3.09 (6.82)
35	1.04 (2.28)	0.83 (1.83)	76	4.77 (10.52)	4.56 (10.04)

MAINTENANCE KITS

MODEL	NITRILE	VITON	LOW TEMPERATURE -60°C (-76°F) MIN.	INCLUDES
RCA10T	K1001	K1002	NA	Diaphragm kits include main and secondary diaphragms (where required) and all springs. *These kits are for discontinued valves.
CA/RCA20T	K2000	K2007	NA	
CA/RCA25T	K2501	K2503	K2504	
CA/RCA32T*	K2500	—	NA	
CA/RCA35T	K3500	K3501	K3502	
CA/RCA40T*	K4000	—	NA	
CA/RCA45T	K4502	K4503	K4522	
CA/RCA50/62T	K5004	K5000	NA	
CA/RCA76T	K7600	K7601	NA	
Pilot repair kit	K0380	K0384	NA	o-ring, armature assembly, armature spring, ferrule

PRODUCT CHARACTERISTICS AND PERFORMANCE

NOM. SIZE	PORT SIZE		NUMBER OF DIAPHRAGMS	KV	FLOW	
	MM	IN			CV	
10	10	3/8	1	2.5	2.9	
20	20	3/4	1	12	14	
25	25	1	1	20	23	
35	40	1.5	1	36	42	
45	40	1.5	2	44	51	
50	50	2	2	76	88	
62	62	2.5	2	91	106	
76	76	3	2	144	167	

Pressure Range: 30(5)–860(125) kPA(Psi)

Temperature Range: Nitrile Seals: -40°C (-40°F) to 82°C (179.6°F)
Viton Seals: -29°C (-20.2°F) to 232°C (449.6°F)

ORDER CODE

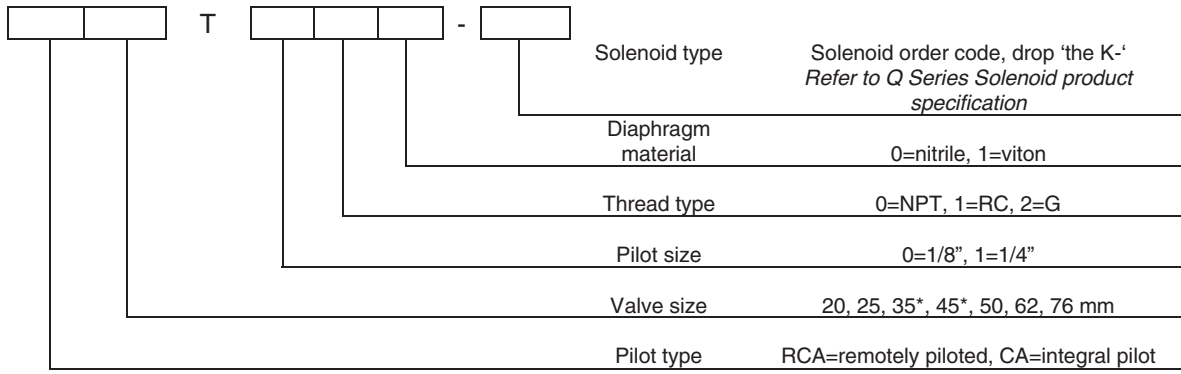

*Note that the 35 & 45 share the same port sizes.

Order Code RCA10T Series

RCA10-6T/645 [1/4 NPT]

RCA10-6T/669 [1/4 BSPT]

Examples: CA50T010-300
 2" threaded port valve with 1/8" pilot, 2" RC port threads, nitrile seals and 200/240 VAC integral pilot with DIN socket terminals.
 RCA25T001
 1" threaded port valve with 1/8" NPT remote pilot port, 1" NPT port threads and viton seals.

DIMENSIONS

(Dimensions in mm and [inches])

RCA10T

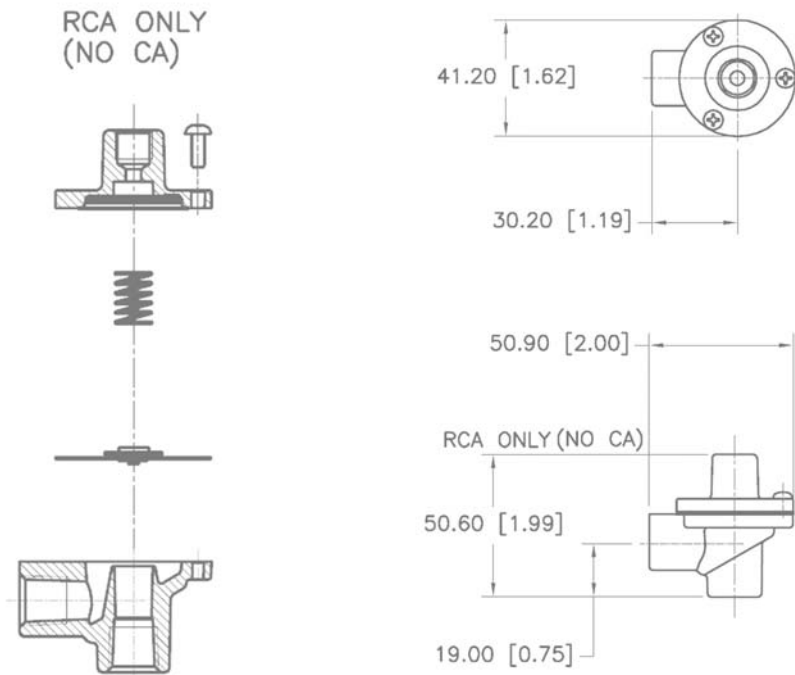

CA/RCA20T

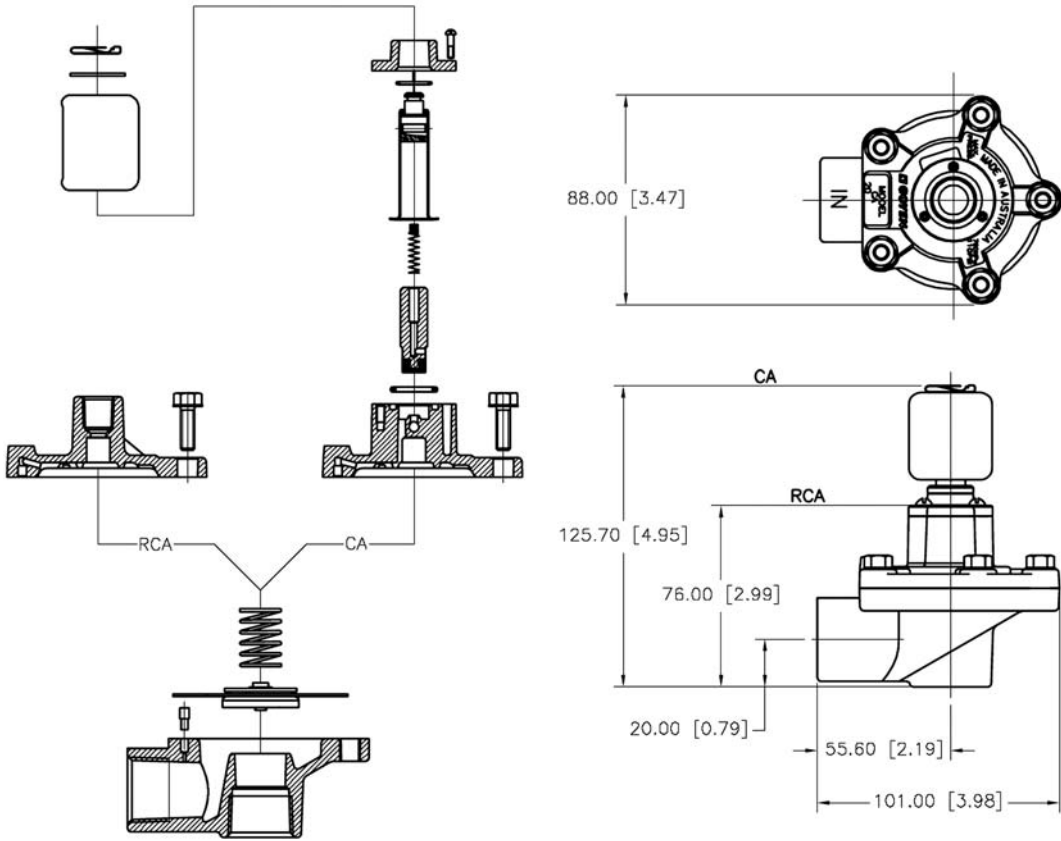

CA/RCA25T

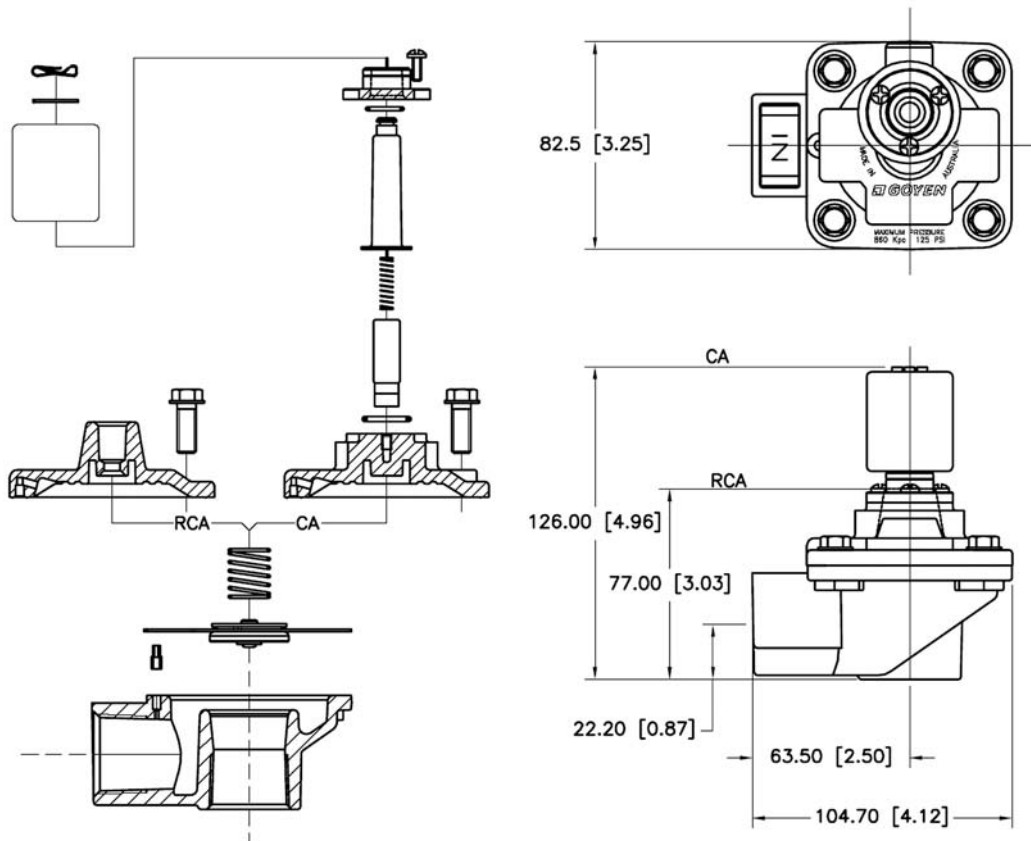

CA/RCA35T

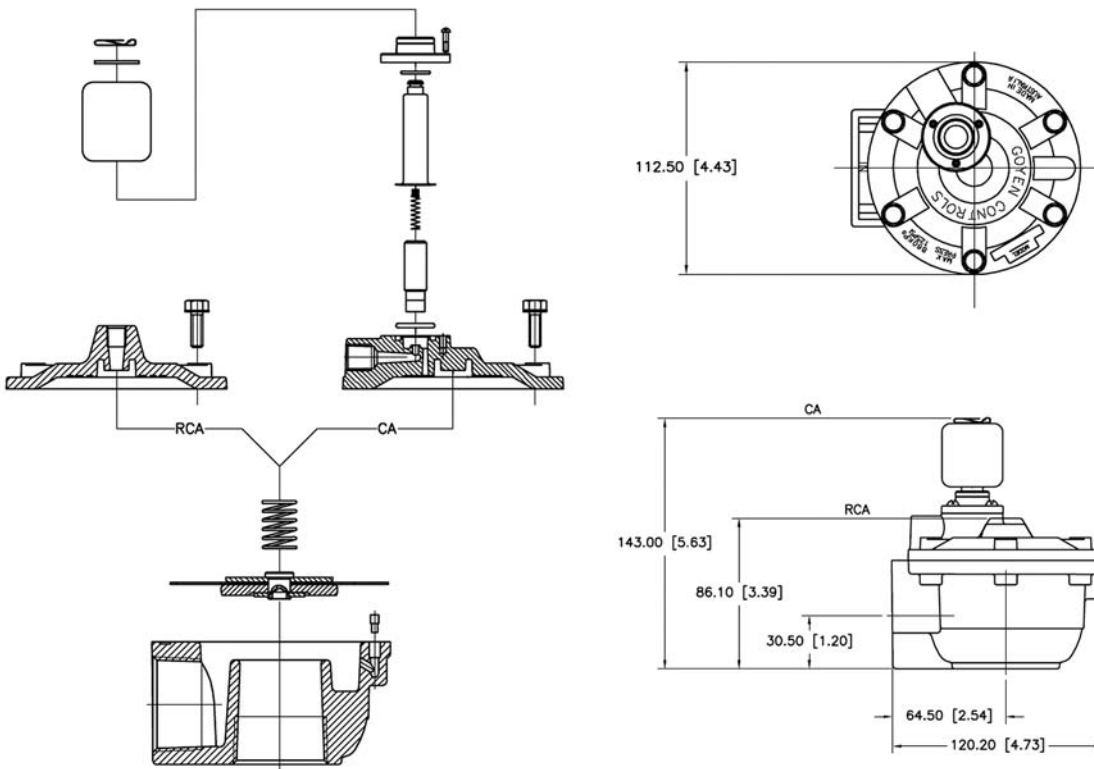

CA/RCA45T

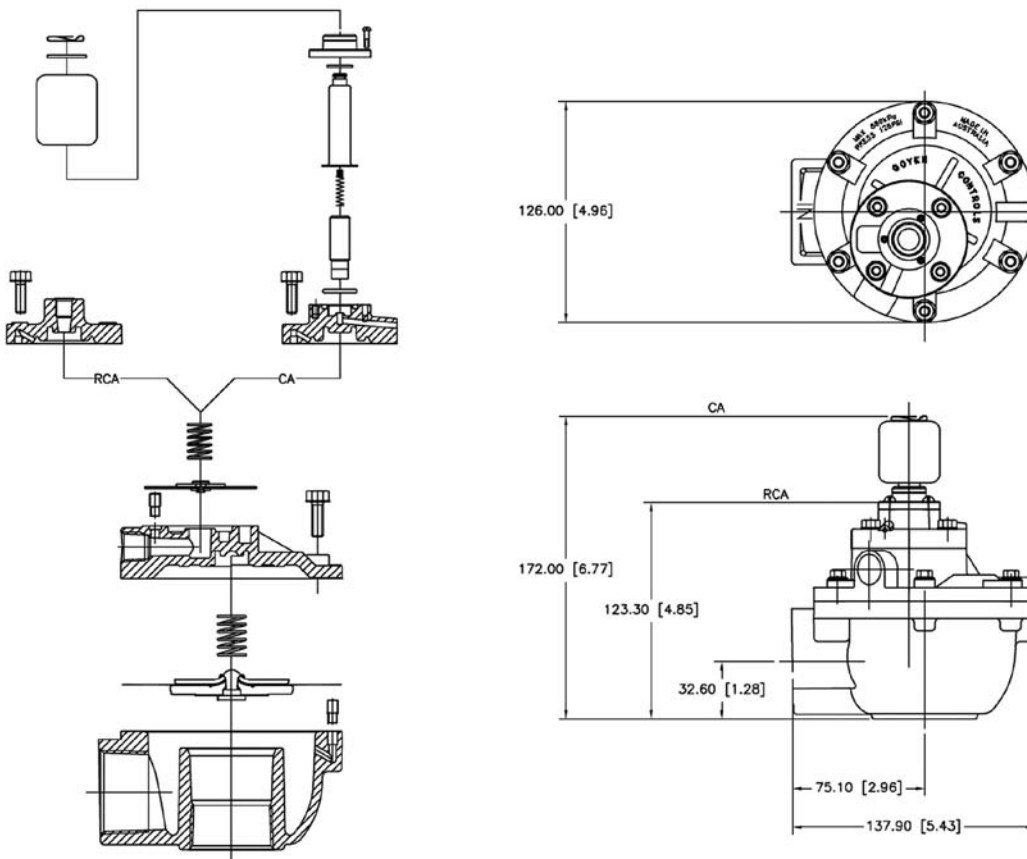

CA/RCA50T

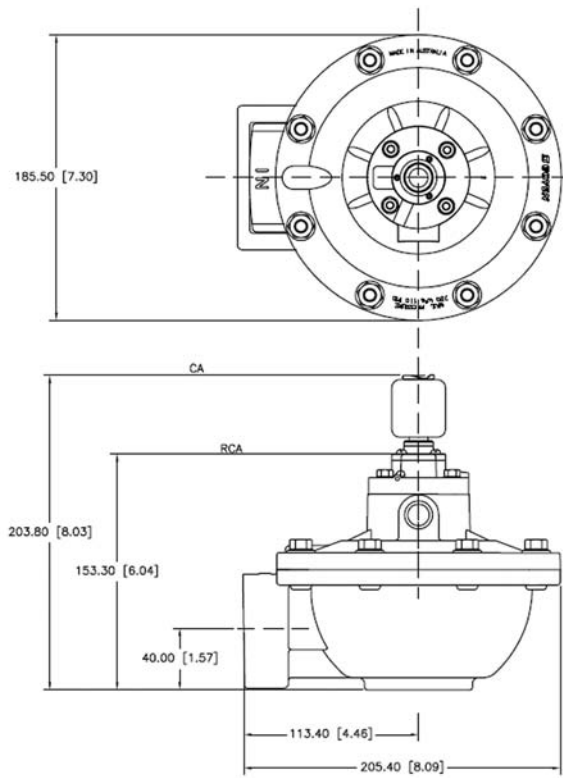
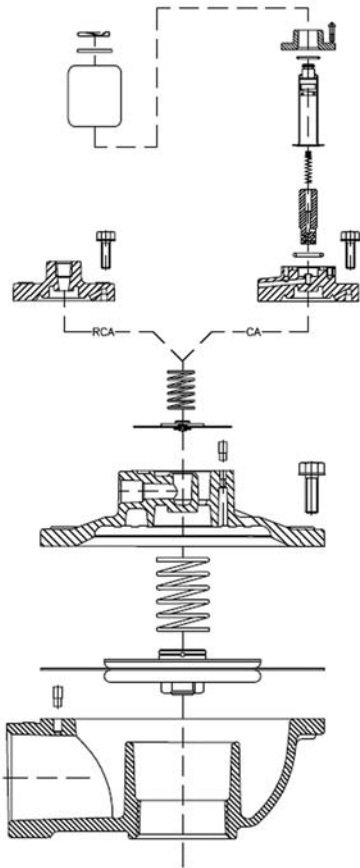

CA/RCA62T

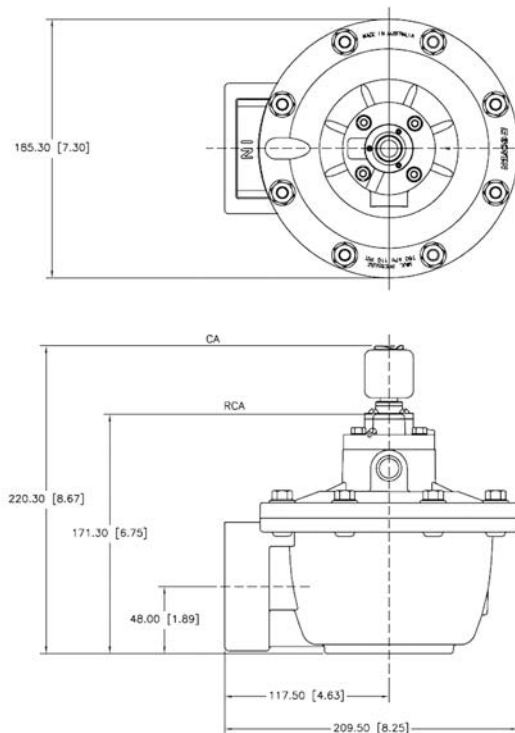
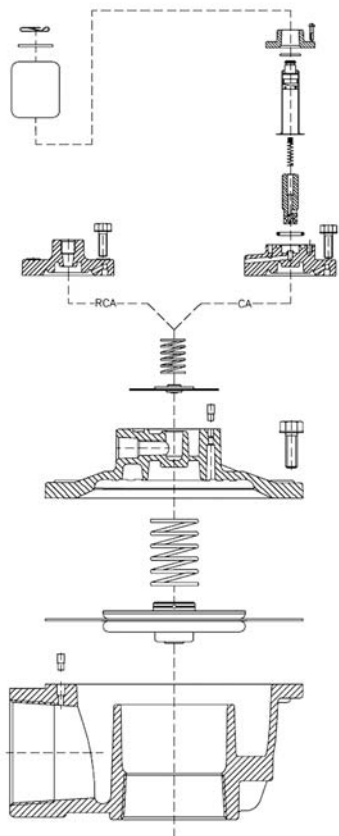

CA/RCA76T

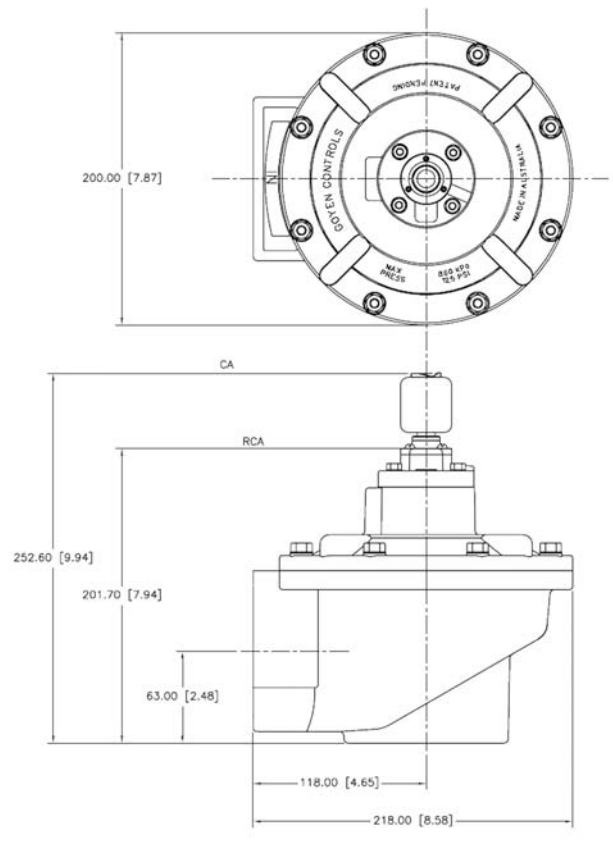
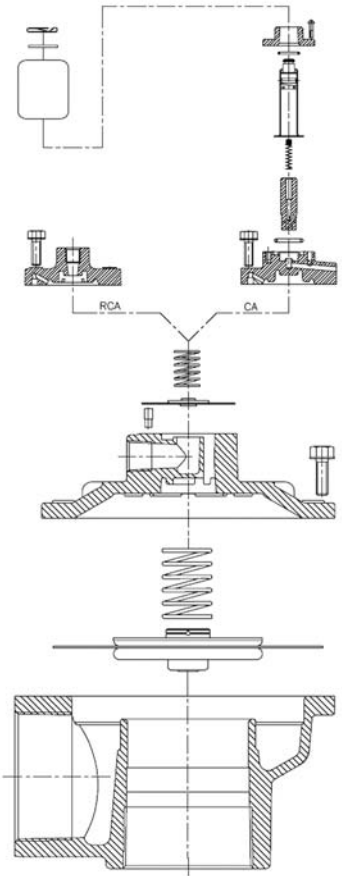

'DD' SERIES

PULSE JET VALVES



DD Series

DESCRIPTION

High performance diaphragm valve with dresser nut ports. Available with integral pilot or as remotely piloted valve. Outlet at 90° to inlet.

SUITABLE FOR

Dust collector applications, in particular for reverse pulse jet filter cleaning and its variations including bag filters, cartridge filters, envelope filters, ceramic filters, and sintered metal fibre filters.

CONSTRUCTION

Body and Dresser

Nuts: Aluminium (diecast)

Ferrule: 304 SS

Armature: 430FR SS

Seals: Nitrile or Viton (reinforced)

Spring: 304 SS

Screws: 302 SS

Dresser Nut Seals: Nitrile or Viton

Diaphragm Seat: PA-6 (standard), Viton coated mild steel or High Density PE

Refer to Q Series Solenoid product data sheet for solenoid construction details.

OPERATION

Recommended

on time range: 50–500 ms

Recommended time

between pulses: 1 minute or greater

MAINTENANCE

Before conducting any maintenance activity on the system ensure that components are fully isolated from pressure and power supplies. Pressure and power should not be reapplied until the valve has been fully assembled.

Diaphragm and pilot inspection should be conducted annually.

APPROVALS

- Atex II 2D Mechanical (RCA Only)
- CSA (U.S) C22.2 No 139–1982, UL 429 (CA & RCA)

- C-Tick (CA)
- EMC 2004/108/EC (CA)
- Low Voltage Directive 2006/95/EC (CA)

INSTALLATION

For your safety do not pressurise system until all valves and pipes are fully secured. Do not attempt to remove a fitted valve while system is under pressure.

1. Prepare supply and blowtube pipes* to suit valve specification. Avoid installing valves underneath the tank.
2. Ensure tank and pipes are free from dirt, rust or other particulate.
3. Ensure supply air is clean and dry.

4. Mount valve to inlet pipes and blowtube to valve, tighten dresser nut.
5. Tanks and pipes must be independently restrained from valve.
6. Make electrical connections to solenoid or connect RCA pilot port to pilot valve (RCA valves only).
7. Apply moderate pressure to system and check for installation leaks.
8. Fully pressurise system.
9. Test fire and listen for proper actuation and crisp pulse noise.

Valve is not a structural component. Do not rely on valve to retain tanks or pipe.

*Pipes must be to Schedule 40 outside diameter

SCHEDULE 40 SIZE	OD MM	OD INCHES
¾"	26.7	1.050
1"	33.4	1.315
1.5"	48.3	1.900

WEIGHTS

SIZE	INTEGRAL PILOT (CA) KG (LBS)	REMOTE PILOT (RCA) KG (LBS)
20	0.82 (1.80)	0.61 (1.34)
25	1.21 (2.67)	0.99 (2.18)
45	2.28 (5.03)	2.11 (4.65)

MAINTENANCE KITS

MODEL	NITRILE	VITON	LOW TEMPERATURE –60°C (–76°F) MIN.	INCLUDES
Diaphragm Kit				
CA/RCA20DD	K2000	K2007	NA	Diaphragm kits include main and secondary diaphragms (where required) and all springs.
CA/RCA25DD	K2501	K2503	K2504	
CA/RCA45DD	K4502	K4503	K4522	
Dresser Seal Kit				
CA/RCA20DD	K2008	K2009	NA	1 dresser seal, 1 dresser nut, 1 seal retainer
CA/RCA25DD	K2508	K2507	NA	1 dresser seal, 1 dresser nut, 1 seal retainer
CA/RCA45DD	K4510	K4511	NA	1 dresser seal, 1 dresser nut, 1 seal retainer
Pilot repair kit (suits all CA valves)	K0380	K0384	NA	o-ring, armature assembly, armature spring, ferrule

PRODUCT CHARACTERISTICS AND PERFORMANCE

NOM. SIZE	PORT SIZE		NUMBER OF DIAPHRAGMS	FLOW		PRESSURE RANGE KPA(P.SI)	TEMPERATURE RANGE °C °(F)	
	MM	IN		KV	CV		NITRILE SEALS	VITON SEALS
20	20	3/4	1	12	14	30(5)-860(125)	-40(-40) to 82(179.6)	-29(-20.2) to 232(449.6)
25	25	1	1	20	23	30(5)-860(125)	-40(-40) to 82(179.6)	-29(-20.2) to 232(449.6)
45	40	1.5	2	44	51	30(5)-860(125)	-40(-40) to 82(179.6)	-29(-20.2) to 232(449.6)

ORDER CODE

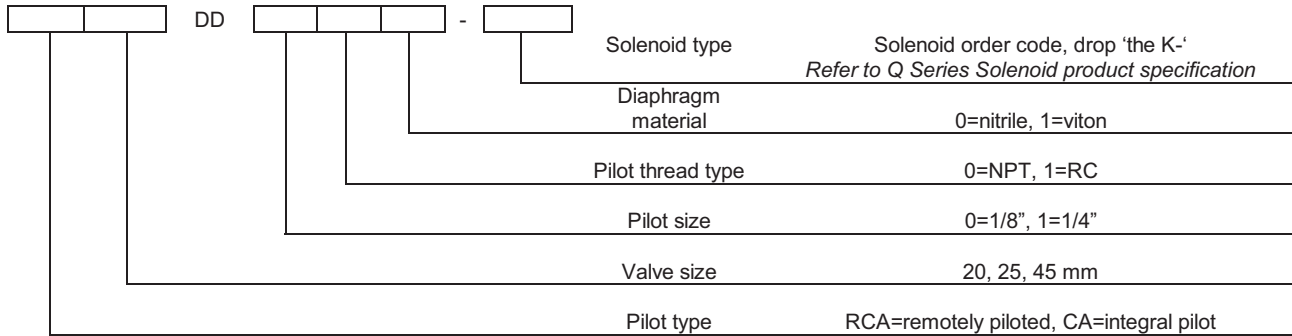

Examples: CA45DD010-300
 1.5" dresser nut port valve with 1/8" RC pilot, nitrile seals and 220/240 VAC integral pilot with DIN socket terminals.
 RCA25DD001
 1" dresser nut port valve with 1/8" NPT remote pilot port and viton seals.

DIMENSIONS

(Dimensions in mm and [inches])

CA/RCA20DD

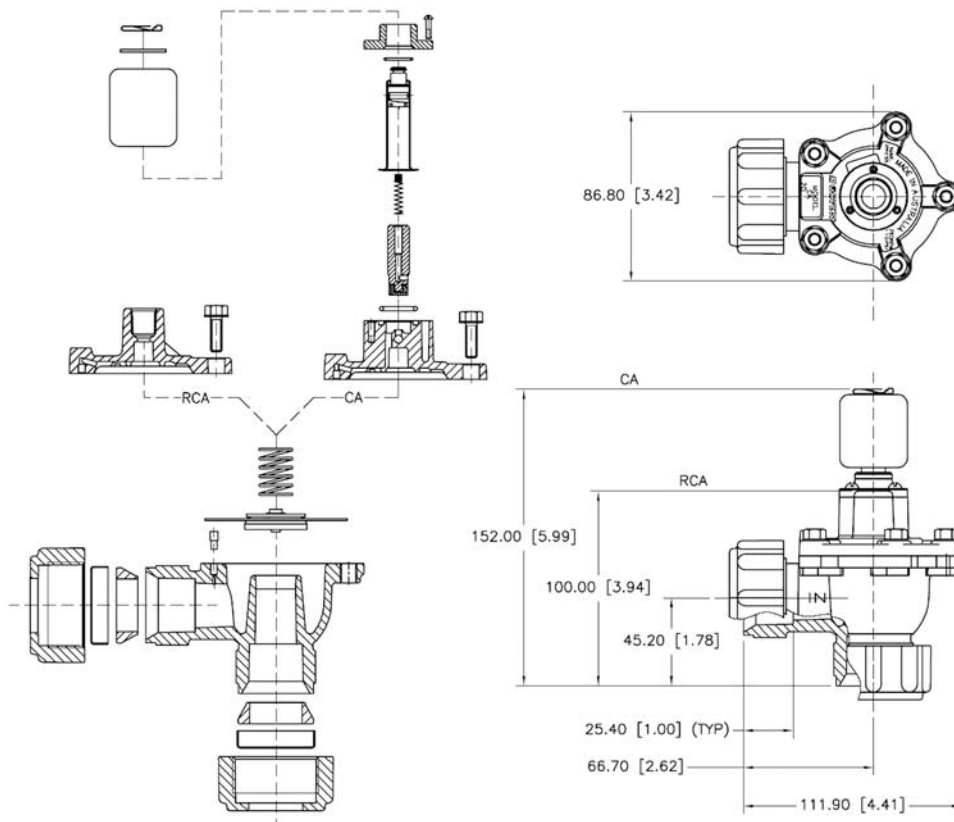

CA/RCA25DD

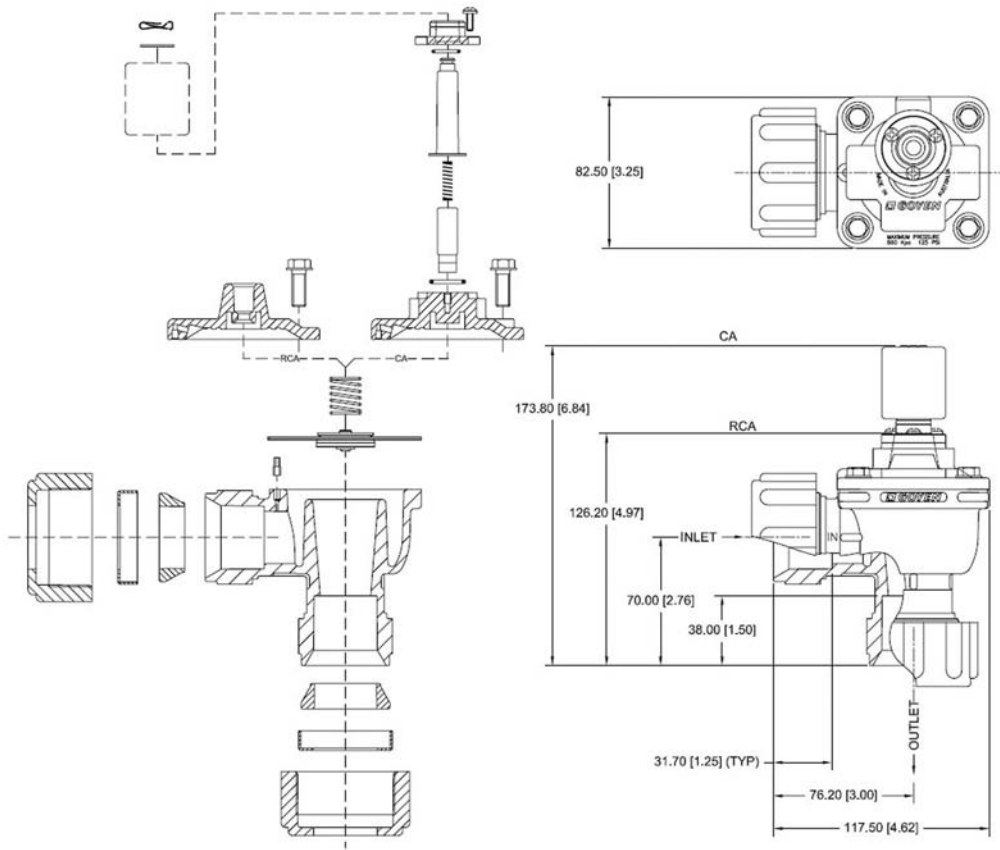

CA/RCA45DD

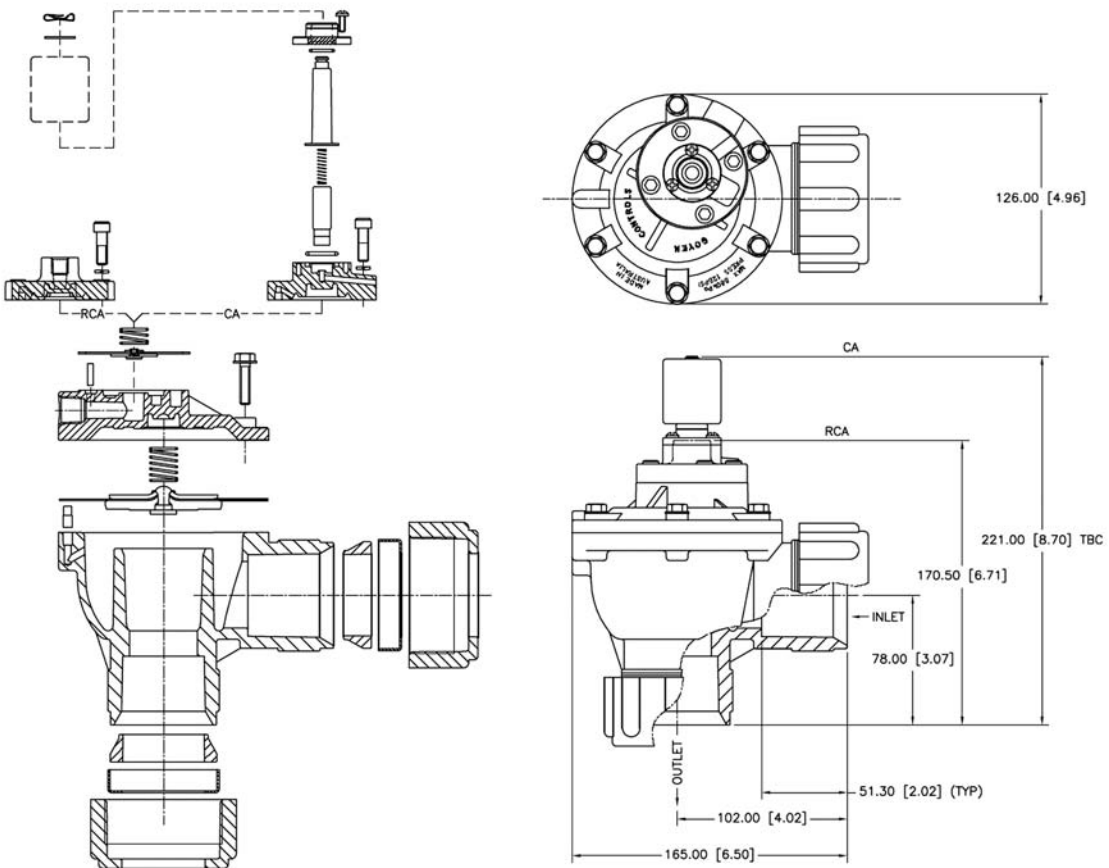

'FS' SERIES

PULSE JET VALVES



FS Series

DESCRIPTION

Very high performance diaphragm valve with flanged inlet port and slide seal outlet port for easy valve installation and removal. Available with integral pilot or as remotely piloted valve. Outlet at 90° to inlet.

SUITABLE FOR

Dust collector applications, in particular for reverse pulse jet filter cleaning including bag filters, cartridge filters, envelope filters, ceramic filters, and sintered metal fibre filters.

CONSTRUCTION

Body: Diecast aluminium or 316 stainless steel

Ferrule: 304 SS

Armature: 430FR SS

Seals: Nitrile or Viton (reinforced)

Spring: 304 SS

Screws: 302 SS

Outlet Slide Seal: EPDM or Viton

Diaphragm Seat: PA-6 (standard), Viton coated mild steel

Refer to Q Series Solenoid product data sheet for solenoid construction details.

OPERATION

Recommended

on time range: 50–500 ms

Recommended time

between pulses: 1 minute or greater

MAINTENANCE

Before conducting any maintenance activity on the system ensure that components are fully isolated from pressure and power supplies. Pressure and power should not be reapplied until the valve has been fully assembled.

Diaphragm and pilot inspection should be conducted annually.

APPROVALS

- Atex II 2D Mechanical (RCA Only)
- CSA (U.S) C22.2 No 139–1982, UL 429 (CA & RCA)
- C-Tick (CA)

- EMC 2004/108/EC (CA)
- Low Voltage Directive 2006/95/EC (CA)

INSTALLATION

1. Prepare inlet flange and blowtube pipes* to suit valve specification. Avoid installing valves underneath the tank.
2. Ensure tank and pipes are free from dirt, rust or other particulate.
3. Ensure supply air is clean and dry.
4. Mount valves to inlet flange and blowtube to valves with all seals in place. Tighten flange bolts to 10Nm (7.4 ft-lbs) Ensure blowtube is pushed all the way into the valve outlet.

5. Tanks and pipes must be independently restrained from valve.
6. Make electrical connections to solenoid or connect RCA pilot port to pilot valve (RCA valves only).
7. Apply moderate pressure to system and check for installation leaks.
8. Fully pressurise system.
9. Test fire and listen for proper actuation and crisp pulse noise.

Valve is not a structural component. Do not rely on valve to retain tanks or pipe. Refer to Camlock product specification for installation details.

SCHEDULE 40 SIZE	OD MM	OD INCHES
1"	33.4	1.315
1.5"	48.3	1.900

WEIGHTS

SIZE	INTEGRAL PILOT (CA) KG (LBS)	REMOTE PILOT (RCA) KG (LBS)
25	1.050 (2.31)	0.830 (1.82)
45	1.830 (4.03)	1.610 (3.55)

MAINTENANCE KITS

MODEL	NITRILE	VITON	INCLUDES
CAC/RCAC25FS Diaphragm kit CA/RCA45FS Diaphragm kit	K2501 K4502	K2503 K4503	The main diaphragm, secondary diaphragm (45FS only) and spring(s).
CAC45FS to CA45FS Integral pilot cover conversion kit	K4532(NPT) K4538(BSP)	K4537(NPT) K4539(BSP)	The complete CA integrally piloted valve cover assembly. Does not include main diaphragm, main diaphragm spring, cover bolts or main bleed pin.
RCAC45FS to RCA45FS Remotely piloted cover conversion kit	K4533(BSP) K4535(NPT)	K4534(BSP) K4536(NPT)	The complete RCA remotely piloted valve cover assembly with main diaphragm and spring. Does not include cover bolts or main bleed pin.
Integral pilot repair kit (CA45FS and CAC25FS only)	K0380	K0384	O-ring armature assembly, armature spring, ferrule.
Integral pilot repair kit (CAC45FS only)	K0390	N/A	O-ring armature assembly, armature spring, ferrule.
25FS Outlet seal	G690763	G690763-2	Outlet seal
45FS Outlet seal	G690864	G690864-2	Outlet seal

PRODUCT CHARACTERISTICS AND PERFORMANCE

NOM. SIZE	PORT SIZE		NUMBER OF DIAPHRAGMS	FLOW		PRESSURE RANGE KPA(PSI)	TEMPERATURE RANGE °C °(F)	
	MM	IN		KV	CV		NITRILE SEALS	VITON SEALS
25	25	1	1	28	32	30(5)–860(125)	–40[–40] to 82(179.6)	–29[–20.2] to 232(449.6)
45	40	1.5	1	56	65	30(5)–860(125)	–40[–40] to 82(179.6)	–29[–20.2] to 232(449.6)

ORDER CODE

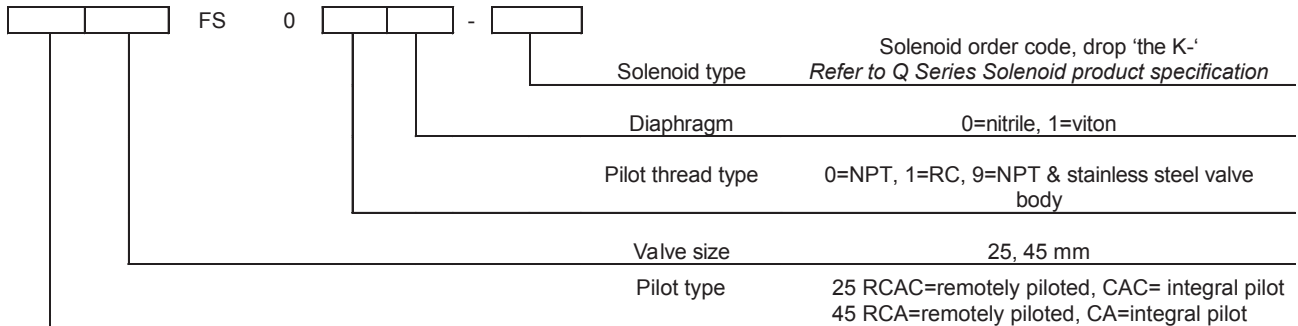

Examples: CA45FS010-300
 1.5" FS valve with 1/8" RC pilot, nitrile seals and 220/240 VAC integral pilot with DIN socket terminals.
 RCAC25FS091
 1" FS valve with 1/8" NPT remote pilot port, stainless steel body and valve cover, and viton seals.

DIMENSIONS

(Dimensions in mm and [inches])

CAC/RCAC25FS

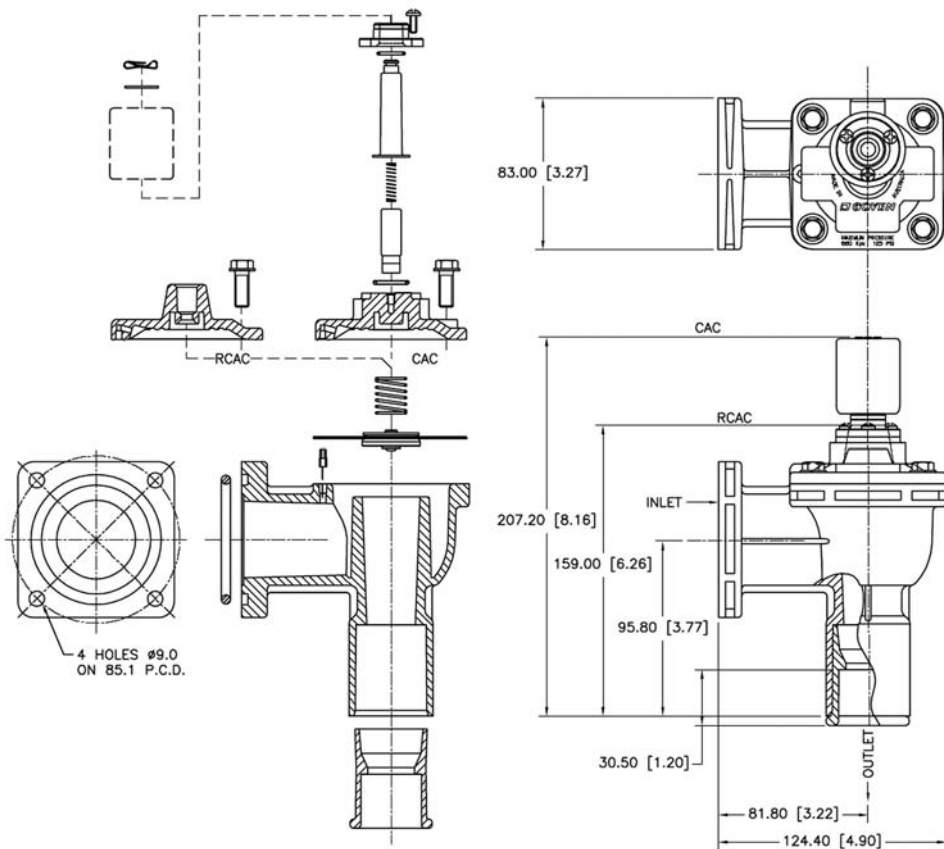

CA/RCA45FS

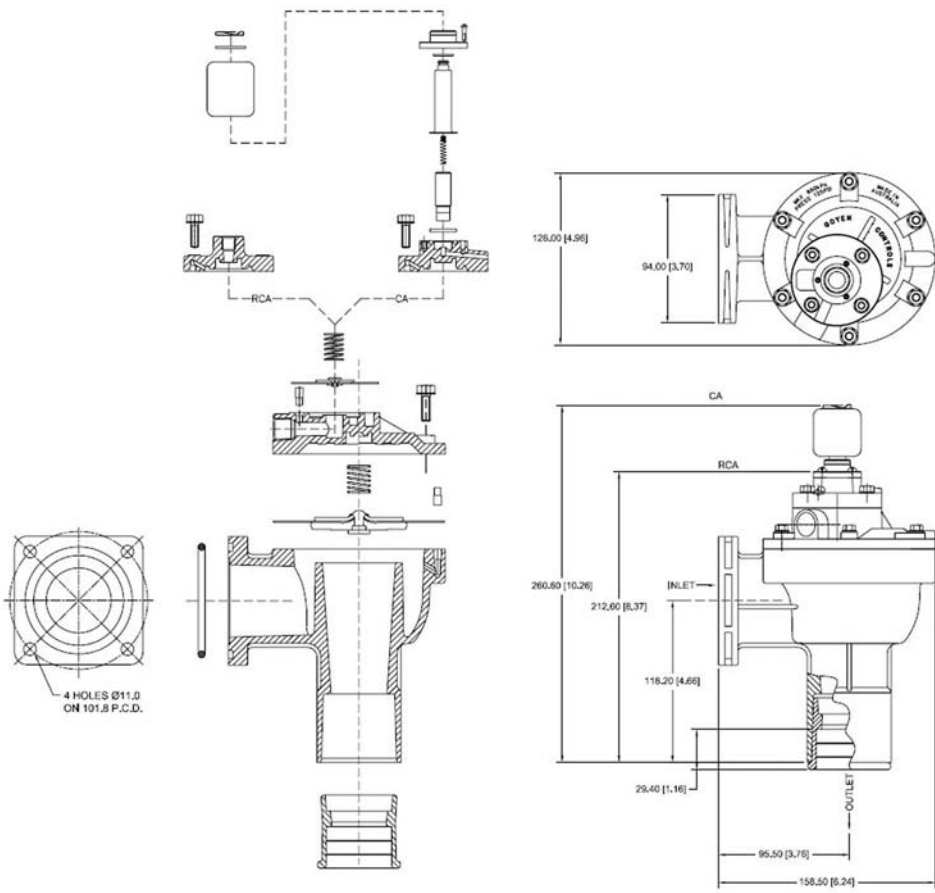

'MM' SERIES PULSE JET VALVES



MM Series

DESCRIPTION

Very high performance diaphragm valve designed to be mounted directly into the compressed air manifold. 1" and 1.5" models are supplied with outlet pipes to length specified, 3" and 3.5" models are supplied without outlet pipes.

SUITABLE FOR

Dust collector applications, in particular for reverse pulse jet filter cleaning including bag filters, cartridge filters, envelope filters, ceramic filters, and sintered metal fibre filters.

CONSTRUCTION

Body and Dresser

Nuts: Diecast Aluminium

Ferrule: 304 SS

Armature: 430FR SS

Diaphragm and Seals: Nitrile or Viton (reinforced)

Spring: 304 SS

Screws: 302 SS

Outlet Pipe: Schedule 40 wrought steel zinc passivated

Diaphragm Seat: PA-6 (25 & 40MM standard), Nitrile coated mild steel (76MM standard), or Viton coated mild steel (all sizes)

Refer to Q Series Solenoid product data sheet for solenoid construction details.

OPERATION

Recommended

on time range: 50–500 ms

Recommended time

between pulses: 1 minute or greater

MAINTENANCE

Before conducting any maintenance activity on the system ensure that components are fully isolated from pressure and power supplies. Pressure and power should not be reapplied until the valve has been fully assembled.

Diaphragm and pilot inspection should be conducted annually.

APPROVALS

- Atex II 2D Mechanical (RCA Only)
- CSA (U.S) C22.2 No 139-1982, UL 429 (CA & RCA)
- C-Tick (CA)
- EMC 2004/108/EC (CA)
- Low Voltage Directive 2006/95/EC (CA)

INSTALLATION

1. MM valves are installed through the tank, refer to the appropriate template listed above.
2. To avoid any potential operational problems it is preferable that the valves are not mounted underneath the tank where condensation may collect. All o-rings should be coated with a silicone based lubricant or similar.
3. Dresser nut seals where used are a pressure seal only, not a structural component. Do not rely on dresser seals to retain either the tanks or blowtubes. Tanks and blowtubes must be independently restrained.
4. Tighten dresser nuts to 20 Nm (15 ftlbs) max.
5. Tighten pipe outlets to 20 Nm (15 ftlbs).
6. Connect to Goyen pilot valve, if remotely actuated.
7. Ensure compressed air supply is dry and free from oil and dirt.
8. Check all cleaning system components are secure before applying pressure.
9. Apply moderate pressure and check for leaks.
10. Fully pressurise system.
11. Test fire and listen for proper actuation and crisp pulse noises.

WEIGHTS

SIZE	INTEGRAL PILOT (CA) KG (LBS)	REMOTE PILOT (RCA) KG (LBS)
25	0.720 (1.59)	0.500 (1.10)
40	1.120 (2.47)	0.900 (1.98)
76	3.900 (8.60)	3.680 (8.11)
102	3.900 (8.60)	3.680 (8.11)

MAINTENANCE KITS AND ACCESSORIES

MODEL	NITRILE	VITON	INCLUDES
CA/RCA25MM Diaphragm kit	K2501	K2503	Diaphragm kits include main and secondary (where required)
CA/RCA40MM Diaphragm kit	K4000	K4007	diaphragms and all diaphragm springs
CA/RCA76MM Diaphragm kit	K7600	K7601	
CA/RCA102MM Diaphragm kit	K10200	K10201	
Pilot repair kit (all models)	K0380	K0384	o-ring, armature assembly, armature spring, ferrule
CA/RCA25MM*P Installation template	Drawing 690048		Installation templates are available free of charge.
CA/RCA25MM*D Installation template	Drawing 690046		
CA/RCA40MM*P Installation template	Drawing 690045		
CA/RCA40MM*D Installation template	Drawing 609999		
CA/RCA76MM Installation template	Drawing 690151 and 690051		
CA/RCA102MM Installation template	Drawing 691055 and 691056		Suitable for 102MM hose

PRODUCT CHARACTERISTICS AND PERFORMANCE

NOM. SIZE	PORT SIZE		NUMBER OF DIAPHRAGMS	FLOW		PRESSURE RANGE KPA(PSI)	TEMPERATURE RANGE °C °(F)	
	MM	IN		KV	CV		NITRILE SEALS	VITON SEALS
25	25	1	1	26	30	30(5)-860(125)	-40(-40) to 82(179.6)	-29(-20.2) to 232(449.6)
40	40	1.5	2	44	51	30(5)-860(125)	-40(-40) to 82(179.6)	-29(-20.2) to 232(449.6)
76	76	3	2	200	233	30(5)-860(125)	-40(-40) to 82(179.6)	-29(-20.2) to 232(449.6)
102	102	3.5	2	238	277	30(5)-860(125)	-40(-40) to 82(179.6)	-29(-20.2) to 232(449.6)

ORDER CODE

1" and 1.5" Models

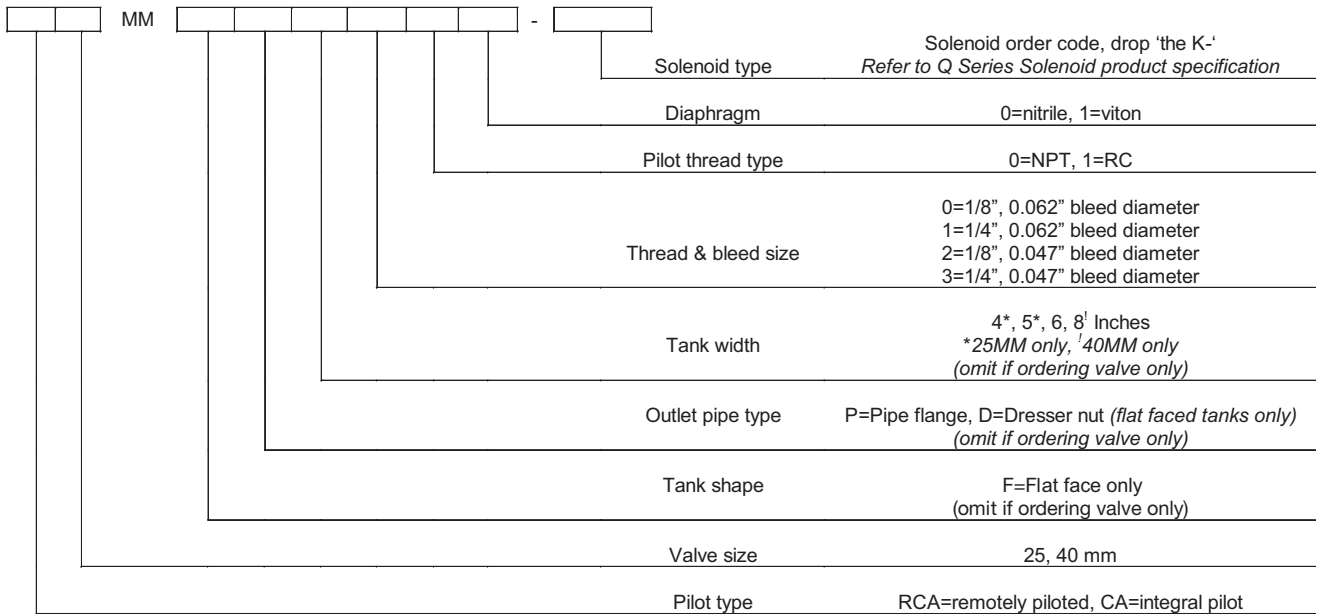

3" and 3.5" Models

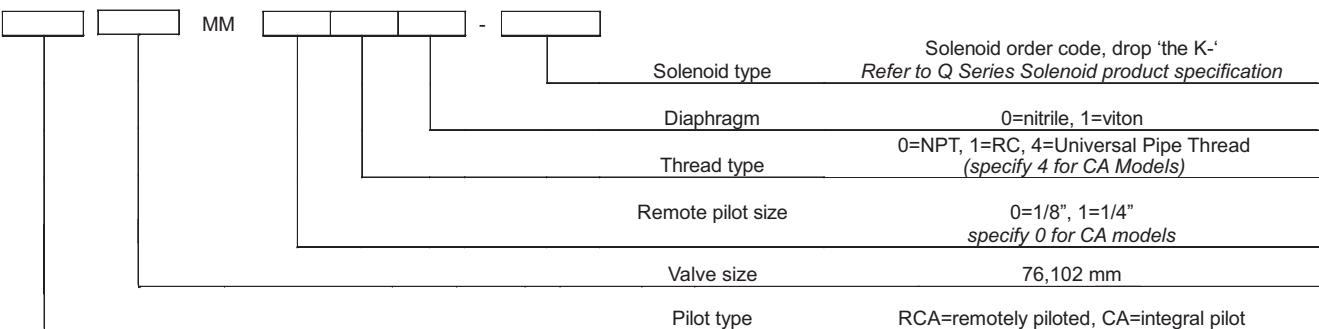

Examples: CA40MMFD6000-300
1.5" MM valve to suit a flat faced tank with a dresser nut outlet, 1/8" NPT exhaust port, Ø0.062" bleed, nitrile seals and 220/240VAC integral pilot with DIN socket terminals.
RCA25MMRP001
1" MM valve to suit a Ø 5" round tank with pipe flange outlet. 1/8" NPT remote pilot port, Ø0.062" bleed and viton seals.
RCA25MM001
1" MM valve only, 1/8" NPT remote pilot, Ø0.062" bleed and viton seals.

DIMENSIONS

(Dimensions in mm and [inches])

CA/RCA25MM

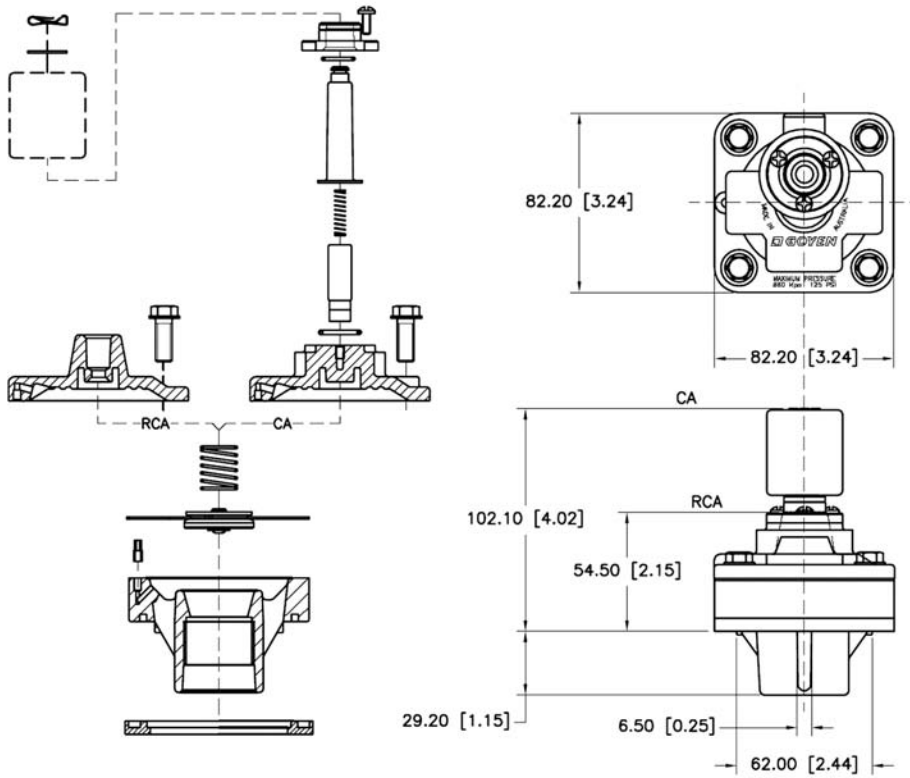

Note: Pipe outlet not shown

CA/RCA40MM

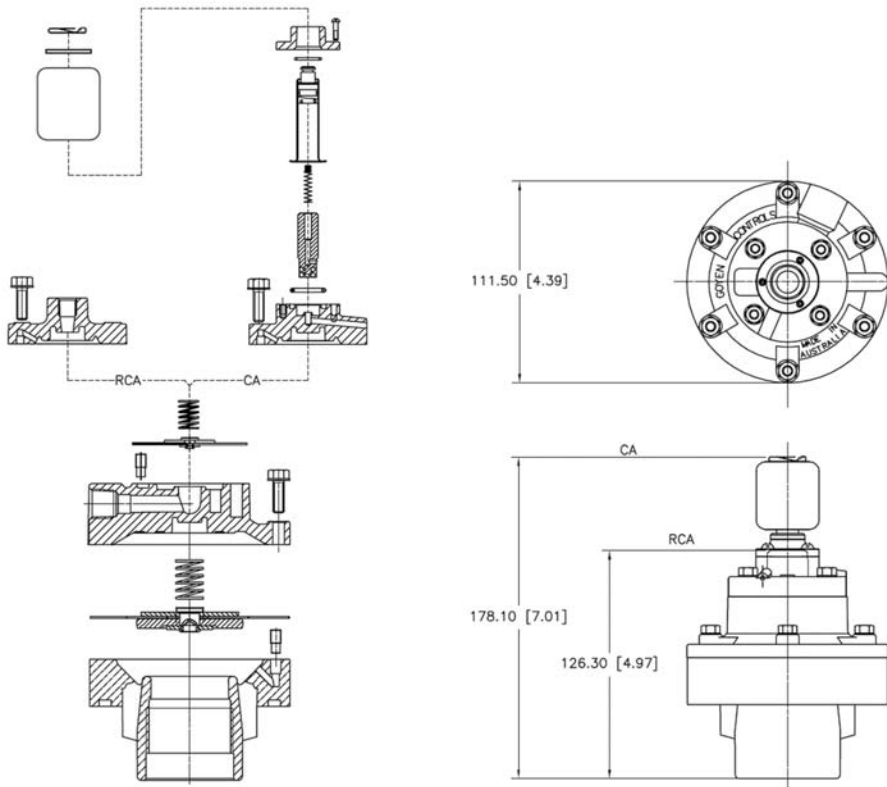

Note: Pipe outlet not shown

CA/RCA76MM

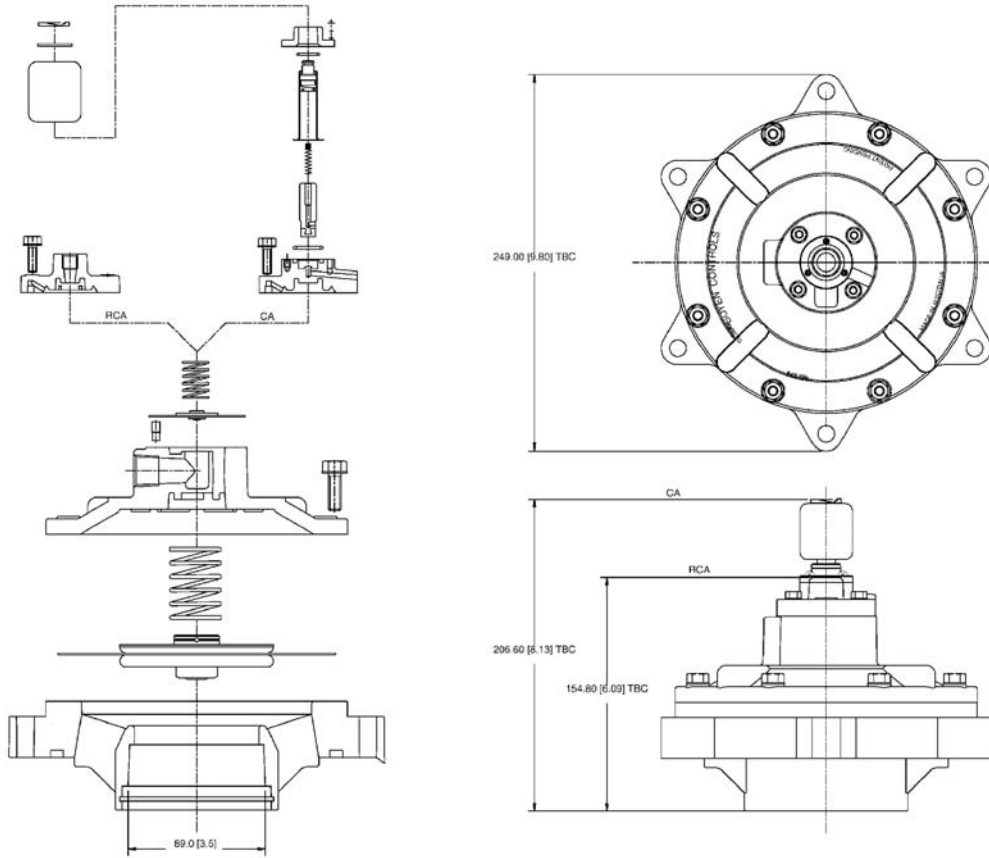

Note: Suggested pipe size is 3" NB Schedule 40 pipe (OD=89.0mm, 3.5")

CA/RCA102MM

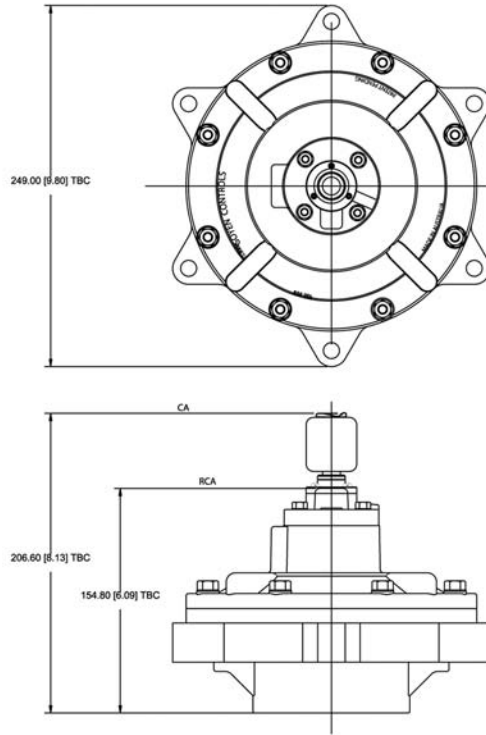
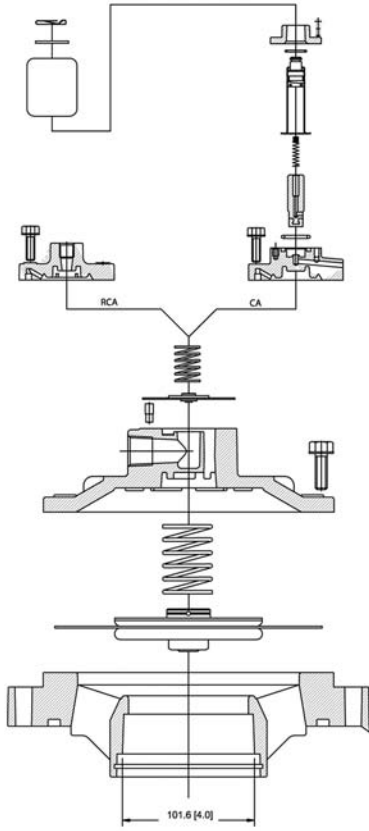

Note: Suggested pipe size is 3.5" NB Schedule 30 pipe (OD=101.6mm, 4")