

**MATERIAL**

Die-cast zinc alloy, epoxy resin coating, black colour, matte finish.

**GRUB SCREW**

Black-oxide steel with brass bolt.

**STANDARD EXECUTIONS**

- **GN 412.1-1:** for front mounting, with pass-through holes for cylindrical-head screws with hexagon socket.
- **GN 412.1-2:** for rear mounting, with threaded blind holes.

**FEATURES AND APPLICATIONS**

GN 412.1 positioning flanges are suitable for example for fastening indexing plungers or vibration damping elements.

For optimal positioning of the plunger of indexing plungers use hexagonal-head positioning bosses GN 412.2 (see page 801) or with conical head GN 412.3 (see page 801).

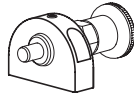
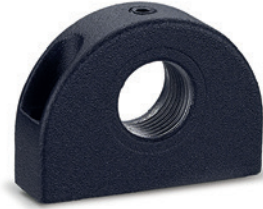

GN 412.1-1

GN 412.1-2

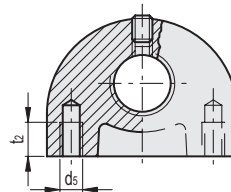
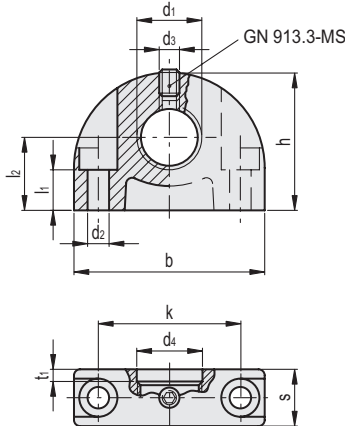

**GN 412.1-1**

Code	Description	d1	d2	d3	d4	b	h	k	l1	l2	s	t1	⚖
GN.41211	GN 412.1-35-M8-1	M8	4.3	M4	8.2	35	26	25	6	14	12	2	41
GN.41213	GN 412.1-35-M8x1-1	M8x1	4.3	M4	8.2	35	26	25	6	14	12	2	41
GN.41215	GN 412.1-35-M10-1	M10	4.3	M4	10.2	35	26	25	6	14	12	2	38
GN.41217	GN 412.1-35-M10x1-1	M10x1	4.3	M4	10.2	35	26	25	6	14	12	2	38
GN.41221	GN 412.1-35-M12-1	M12	4.3	M4	12.2	35	26	25	6	14	12	3	37
GN.41223	GN 412.1-35-M12x1.5-1	M12x1.5	4.3	M4	12.2	35	26	25	6	14	12	3	37
GN.41225	GN 412.1-47-M16-1	M16	5.3	M5	16.2	47	34	35	10	18	14	3	76
GN.41227	GN 412.1-47-M16x1.5-1	M16x1.5	5.3	M5	16.2	47	34	35	10	18	14	3	77
GN.41229	GN 412.1-47-M20x1.5-1	M20x1.5	5.3	M5	20.2	47	34	35	10	18	14	3	78

**GN 412.1-2**

Code	Description	d1	d3	d4	d5	b	h	k	l2	s	t1	t2 min.	⚖
GN.41212	GN 412.1-35-M8-2	M8	M4	8.2	M5	35	26	25	14	12	2	10	48
GN.41214	GN 412.1-35-M8x1-2	M8x1	M4	8.2	M5	35	26	25	14	12	2	10	48
GN.41216	GN 412.1-35-M10-2	M10	M4	10.2	M5	35	26	25	14	12	2	10	46
GN.41218	GN 412.1-35-M10x1-2	M10x1	M4	10.2	M5	35	26	25	14	12	2	10	46
GN.41222	GN 412.1-35-M12-2	M12	M4	12.2	M5	35	26	25	14	12	3	12	44
GN.41224	GN 412.1-35-M12x1.5-2	M12x1.5	M4	12.2	M5	35	26	25	14	12	3	12	44
GN.41226	GN 412.1-47-M16-2	M16	M5	16.2	M6	47	34	35	18	14	3	12	90
GN.41228	GN 412.1-47-M16x1.5-2	M16x1.5	M5	16.2	M6	47	34	35	18	14	3	12	70
GN.41230	GN 412.1-47-M20x1.5-2	M20x1.5	M5	20.2	M6	47	34	35	18	14	3	12	79



Indexing and positioning elements