

REVISIONS					
REV	ECO	DESCRIPTION	DATE	BY	APPR
A1		RELEASE NEW PRODUCT	09MAR17	ORION	TOMMY

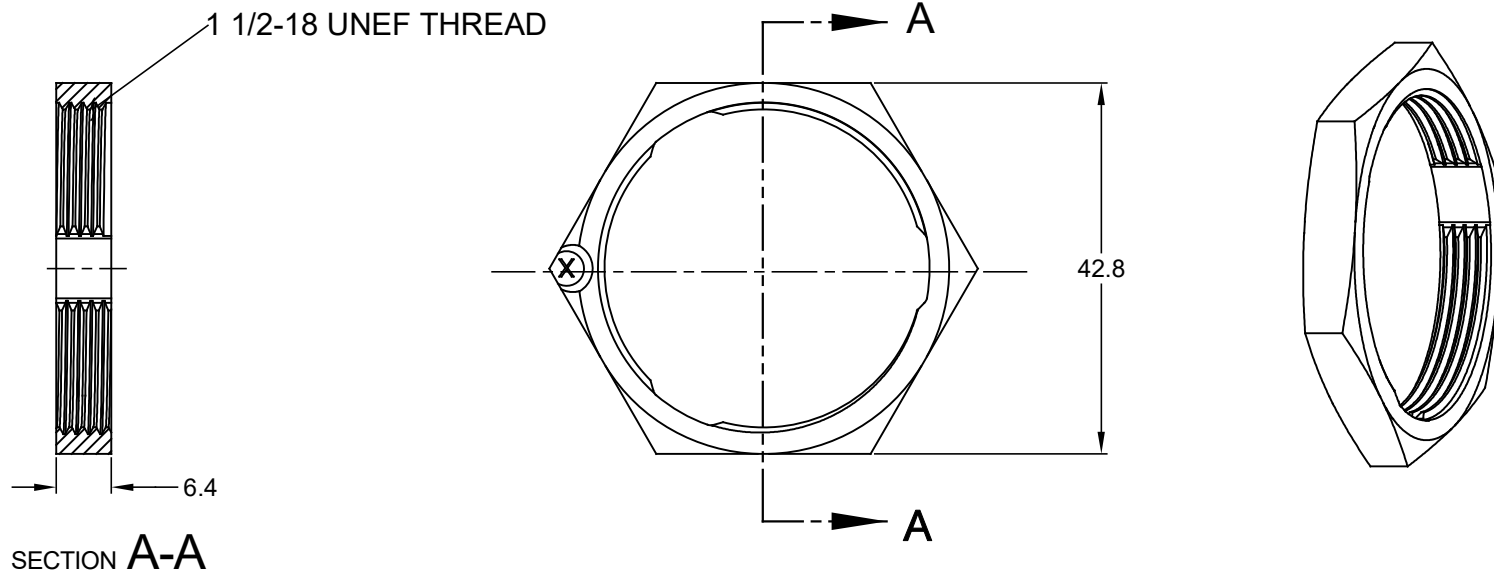

NOTES: UNLESS OTHERWISE SPECIFIED

1. MATERIAL: THERMOPLASTIC
2. COLORS: BLACK
3. RoHS COMPLIANT
4. USE WITH AHDP SERIES SIZE 18 RECEPTACLE, MOUNTING TORQUE IS 5.1~6.1 N.M
5. ALL DIMENSIONS ARE FOR REFERENCE USE ONLY.

AHDP18-PN01		DESCRIPTION		ITEM
PART NUMBER		DESCRIPTION		ITEM
QUANTITY	MATERIALS LIST			
UNLESS OTHERWISE SPECIFIED		SIGNATURES		DATE
1) All dimensions are in metric(mm).		DRAWN: ORION.LI		09MAR17
2) Tolerances are as follows:		CHECKED:		
1 PL DEC ±0.30		ENGINEER:		
2 PL DEC ±0.15		APPROVAL: TOMMY.XIE		09MAR17
3 PL DEC ±0.08		CUSTOMER:		
3) Note reference =		THIS DRAWING IS SUPPLIED FOR INFORMATION ONLY. DESIGN FEATURES, SPECIFICATIONS AND PERFORMANCE DATA SHOWN HEREON ARE THE PROPERTY OF THE AMPHENOL CORPORATION. NO RIGHTS OF REPRODUCTION ARE IMPLIED. ALL DIMENSIONS ARE SUBJECT TO NORMAL MANUFACTURING VARIATIONS.		
MATERIAL SPECIFICATIONS:		SIZE		REVISION
PROCESS SPECIFICATIONS:		TYPE		
NEXT ASSY:		DWG NO:		
		A C-		AHDP18-PN01
		SCALE: NONE		A1
		SHEET 1 OF 1		

Amphenol

Sine Systems - www.amphenol-sine.com
44724 Morley Drive
Clinton Township, MI 48036

NUT, DURAMATE AHDP SERIES, SIZE 18