

	1/4"	3/8"	1/2"	3/4"	1"	1"1/4	1"1/2	2"
DN	8	10	15	20	25	32	40	50
A	44,4	44,4	48	53	66	76	88	103
B	23,5	24	29	36	43	53	63	79
C	42	42	44	55	59	74	79	95
D	85,5	85,5	85,5	113,5	113,5	138	138	157,5
E	10	10	14	18,5	23,5	30	37	47
F	10	10	12	12	15	16	18	19
Kg/cm ² bar	50	50	30	30	30	25	25	25
LBS - psi	725	725	435	435	435	362,5	362,5	362,5

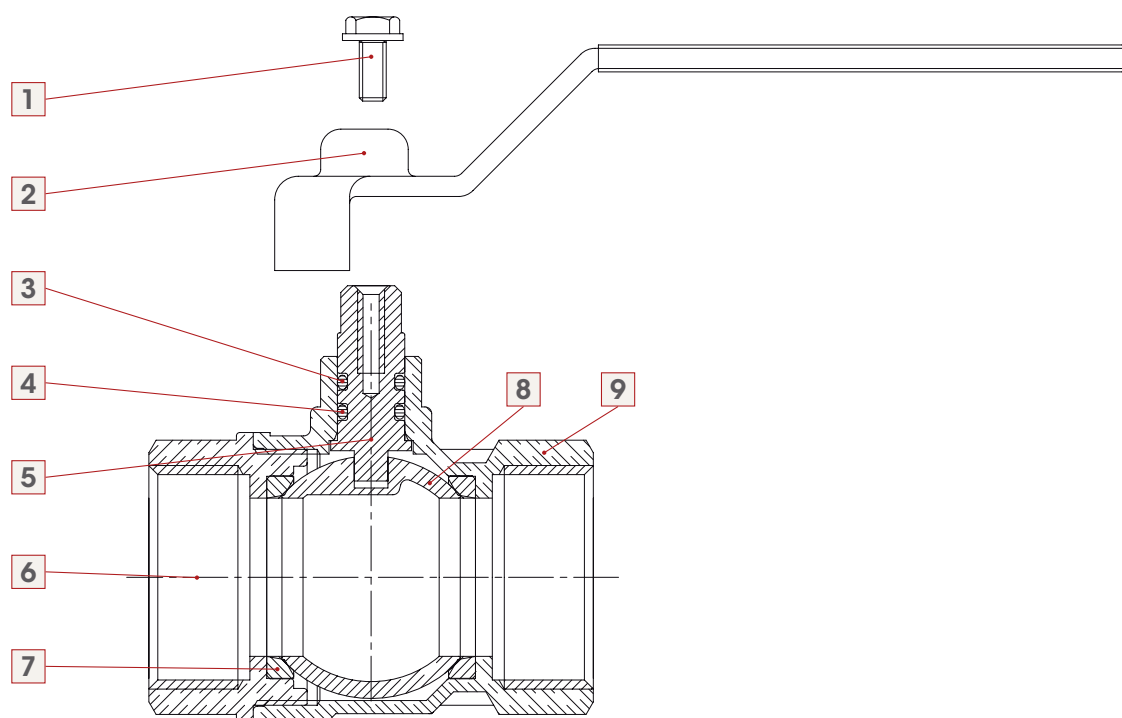

Pos.	DESCRIZIONE / DESCRIPTION	Qt.	MATERIALE / MATERIAL
1	Vite / Screw	1	Acciaio zincato / Zinc-plated steel Fe CB4
2	Maniglia a leva piatta / Flat lever handle	1	Acciaio zincato / Zinc-plated steel Fe.P.04
3	Guarnizione / O-ring	1	VITON®
4	Guarnizione / O-ring	1	NBR
5	Asta di manovra / Stem	1	Ottone / Brass CW614N
6	Manicotto / End adapter	1	Ottone nickelato / Nickel-plated brass CW617N
7	Sede / Seat	2	P.T.F.E.
8	Sfera / Ball	1	Ottone cromato / Chrome-plated brass CW617N
9	Corpo / Body	1	Ottone nickelato / Nickel-plated brass CW617N

INSTALLATION

Installation

The itap S.p.A.'s valves are bi-directional, in the sense that they manage the flow in both the directions. The valves are composed by a ball, two seal in PTFE material, one stem, two sailing rings (O-Rings), one handle and a couple of parts made of brass (body and end adopter) that contain them and that are assembled by means of thread and a sealed material to obtain their aim. To avoid that the sealing material gets brake and than the valve gets lose the connection between body and the end adopter, it's necessary to avoid to submit the two parts under the influence of a torque.

For their installation ones have to use the normal hydraulic practices, and in particular:

- Ones have to be sure that the two pipes are correctly allied,
- during the assembling ones have to apply the assembling tool at the end that is nearest to the pipe,
- the application of the sealing materials by the fitter (PTFE or hempen cloth) must be limited at the thread zone. An excess should interferes in the ball-gasket's closure zone, compromising the tightness.
- In the case that the fluid transported presents some impurities (dust, water too hard, etc.) ones have to remove these impurities by the means of a filter. Otherwise they could damage the seals.

Disassembly the installed valve

To remove the valve from the pipe line or anyhow before to unscrew the junctions linked to it:

- wear the clothing protective normally required to work with the fluid transported within the line.
- Take out the pressure inside the line and operate in this way:
 - positioning the valve in opened position and than empty the line
 - handle the valve to put down the residue pressure contained inside the space between the ball and the body before of remove it from the line,
- during the disassembly apply the screw tool at the end of the valve nearest the pipe

Maintenance

Verify the valves periodically, in function oh their application's field and in function of their work conditions, to be sure that the valves work correctly.

LOSS WITH WATER DIAGRAM

Art: 116 - 117 - 118 - 119 - 216 - 217

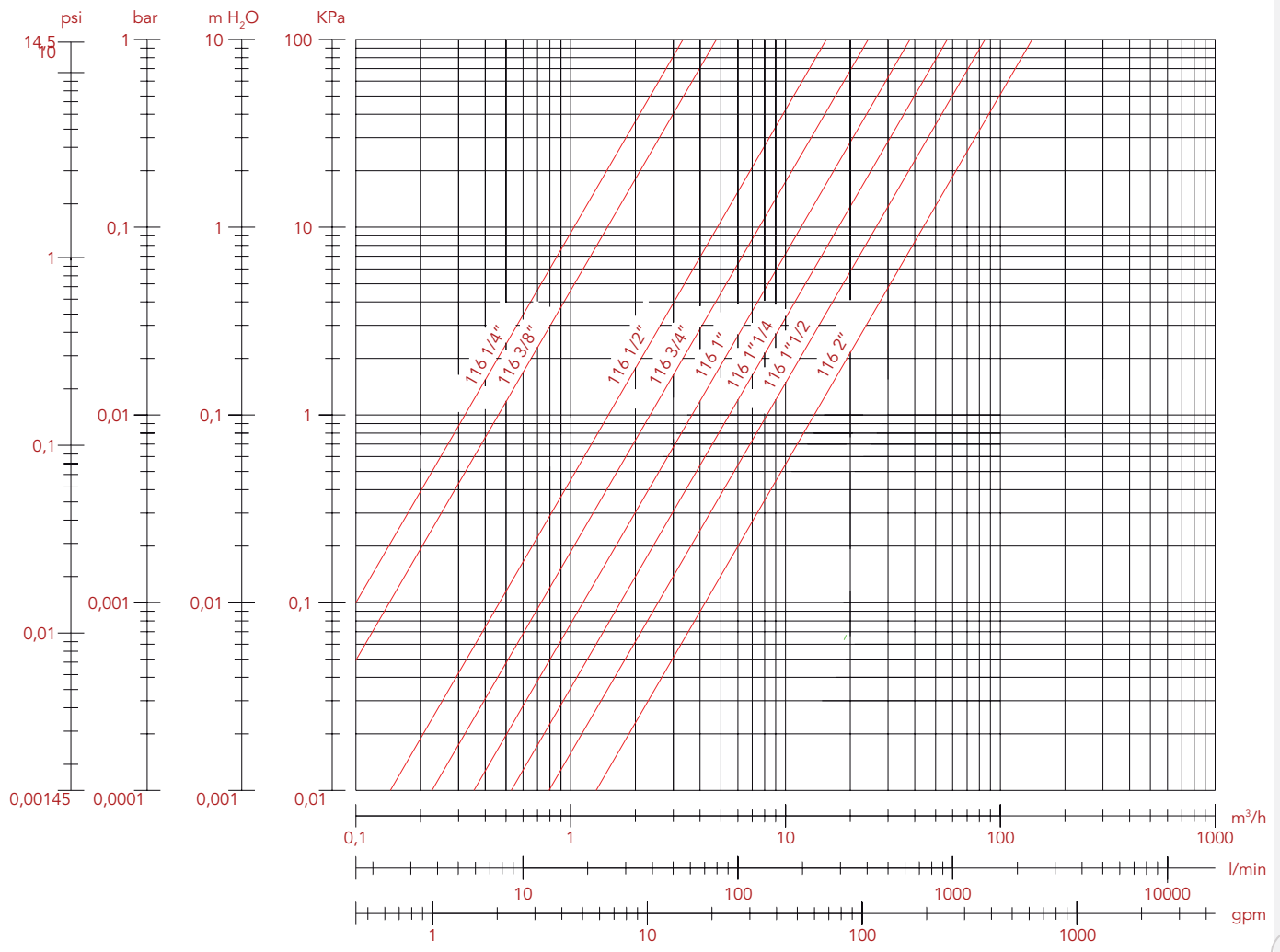

MISURE	1/4"	3/8"	1/2"	3/4"	1"	1"1/4	1"1/2	2"
∅	10	10	14	18,5	23,5	30	37	47
Kv	3,33	4,92	14,65	23,46	38,67	56,07	86,60	160,25



DECLARATION OF CONFORMITY

(According to EN ISO/IEC 17050-1)

The ITAP S.p.A. manufacturer of valves, fittings, manifolds and accessories for thermo-sanitary plants, with head office in via Ruca 19/21 – 25065 Lumezzane S.S. (BS) Italy.

DECLARES

Under its sole responsibility that the VIENNA® standard flow ball valves have been built according to industry standards and conform to their technical specifications, respecting the Company Quality System complies with UNI EN ISO 9001.

Lumezzane 19 November 2013

Industrial Manager.

ITAP S.p.A.
IL CONSIGLIERE DELEGATO
EZIO PATTI

DECLARATION OF CONFORMITY