

MD42005C6W-FPTLRGB	4 x 20	5mm Character Height	LCD Module
Specification			
Version: 1		Date: 15/07/2017	
Revision			
1	13/07/2017	First Issue	

Display Features		
Character Count	4 x 20	
Appearance	Black on RGB	
Logic Voltage	5V	
Interface	Parallel	
Font Set	English / Japanese	
Display Mode	Transflective	
Character Height	4.75mm	
LC Type	FSTN	
Module Size	98.00 x 60.00 x 14.00 mm	
Operating Temperature	-20°C ~ +70°C	
Construction	COB	
LED Backlight	RGB	Weight / Display

* - For full design functionality, please use this specification in conjunction with the ST7066U + ST7063C specification. (Provided Separately)

Display Accessories	
Part Number	Description
MCCMDB-16SIL	LCD Interconnect board, can be driven from either a PC or a single Board computer with a USB output.
MCCBL1A16SLIP-16DILS-150	16 Way, Single in-line to Dual In-line connector Cable.
MCCBL1A16SLIP-16SILS-150	16 Way, Single in-line to Single In-line connector Cable.

Optional Variants		
Fonts	Appearances	Voltage



FEATURES

AVAILABLE OPTIONS	CHARACTERISTICS
DISPLAY FORMAT	20 Characters by 4 Lines
POLARIZER OPTIONS	Positive Transflective
BACKLIGHT TYPE OPTIONS	Edge Type LED Backlight (Long life span version)
BACKLIGHT COLOR OPTIONS	RGB color
LCD PANEL OPTIONS	FSTN
VIEWING ANGLE OPTIONS	6:00 (Bottom)
TEMPERATURE RANGE OPTIONS	-20°C ~ 70°C, Single Supply Voltage
SUGGESTED DRIVING VOLTAGE	V _{lcm} = 5.0V V _{led} = 5.0V
SUGGESTED LED DRIVING MODE	PIN15: LED+, PIN16:K(R),PIN17:K(G),PIN18:K(B)
CONTROLLER	ST7066U+ ST7063C
FONT MAP CODE	E Version
DRIVING DUTY	1/16
DRIVING BIAS	1/5

MECHANICAL SPECIFICATIONS

OVERALL SIZE	98.0W x 60.0H	mm	THICKNESS	max 14.0	mm
VIEWING AREA	76.0W x 25.2H	mm	HOLE-HOLE	93.0W x 55.0H	mm
CHARACTER SIZE	2.95W x 4.75H	mm	CHARACTER PITCH	0.60W x 0.60H	mm
DOT SIZE	0.55W x 0.55H	mm	DOT PITCH	0.05W x 0.05H	mm

ABSOLUTE MAXIMUM RATINGS

ITEM	SYMBOL	CONDITION	MIN	TYP	MAX	UNIT
POWER SUPPLY (LOGIC)	V _{dd}	25°C	-0.3	—	7.0	V
POWER SUPPLY (LCD)	V ₀	25°C	V _{dd} -13.5	—	V _{dd} +0.3	V
INPUT VOLTAGE	V _{in}	25°C	-0.3	—	V _{dd} +0.3	V
OPERATING TEMPERATURE	V _{opr}	—	-20	—	70	°C
STORAGE TEMPERATURE	V _{stg}	—	-30	—	80	°C

ELECTRONIC CHARACTERISTICS

	ITEM	SYMBOL	CONDITION	MIN	TYP	MAX	UNIT
	INPUT VOLTAGE	V _{dd}	—	—	5.0	—	V
	SUPPLY CURRENT	I _{dd}	V _{dd} =5V	—	1.5	—	mA
	DRIVING VOLTAGE FOR LCD PANEL	V _{lcd} = (V _{dd} - V ₀)	-20°C	4.3	—	4.8	V
			0°C	4.2	—	4.7	
			25°C	4.1	4.5	4.7	
			50°C	4.1	—	4.6	
			70°C	4.0	—	4.5	

LCD CHARACTERISTICS

FOR STN/FSTN TYPE LCD Panel (TA=25°C, VIcd=5.0V ± 0.5V)							
	ITEM	SYMBOL	CONDITION	MIN	TYP	MAX	UNIT
	VIEWING ANGLE	$\Phi 2 - \Phi 1$	K=4	40	—	—	deg
		θ		60			
	CONTRAST RATIO	K	—	6	—	—	—
	RESPONSE TIME(RISE)	TR	—	—	150	250	ms
	RESPONSE TIME(FALL)	TF	—	—	150	250	ms

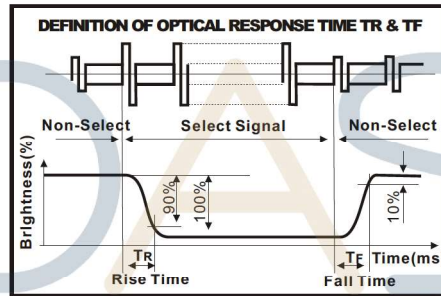
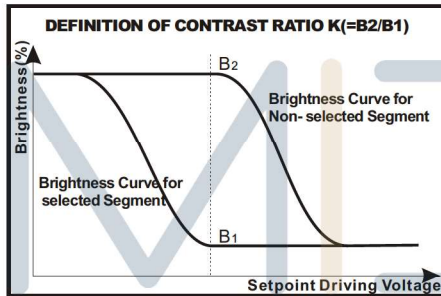
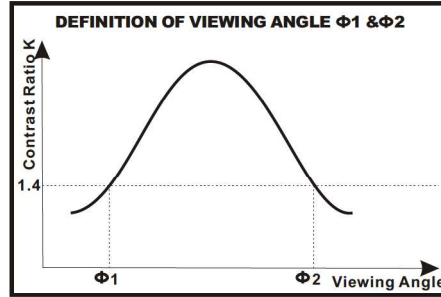
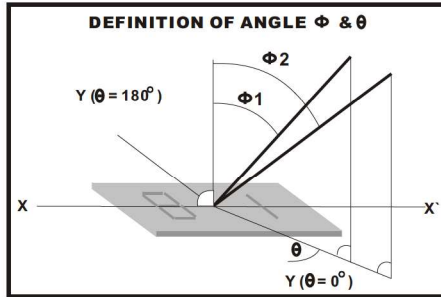

LED CHARACTERISTICS

	ITEM	SYMBOL	CONDITION	MIN			TYP			MAX			UNIT
	LED FORWARD VOLTAGE	Vf	25°C	R	G	B	R	G	B	R	G	B	V
				1.8	2.9	2.9	—	—	—	2.2	3.4	3.4	
	LED FORWARD CURRENT ▲2	If	25°C	—	—	—	—	—	—	20	20	20	mA
	LED REVERSE CURRENT	Ir	25°C	—	—	—	—	—	—	10	10	10	μA/LED
	LED PEAK WAVE LENGTH	λp	25°C	620	520	465	—	—	—	630	530	475	nm
	LED BRIGHTNESS (WITHOUT LCD)	Lv	25°C	—	—	—	22	100	23	—	—	—	cd/m ²
	LED BRIGHTNESS UNIFORMITY	Lvmin/Lvmax	25°C	70			—			—			Ratio
	LED LIFE TIME	—	25°C	20K			—			—			Hours

▲2 请注意, 驱动背光考虑的是恒流而不是恒压. 所以, 这个数值非常重要!

YOUR ATTENTION: It is constant current (not constant voltage) that should be applied when driving LED backlight. Therefore, this data is very important!

* 当工作温度高于25°C时, Ifm, Ifp和Pd必须降低; 电流降低率是 -0.36*4mA/°C (直流驱动), 或-0.86*4mA/°C (脉冲驱动), 功率降低率是-75*4mW/°C. 产品工作电流不能大于对应的工作条件温度Ifm或Ifpr的60%.

For operation above 25°C, The Ifm Ifp & Pd must be derated, the Current derating is -0.36*4mA/°C for DC drive and -0.86*4mA/°C for Pulse drive, the power dissipation is -75*4 mW/°C The product working current must not be more than 60% of the Ifm or Ifp according to the working temperature.



PIN ASSIGNMENT

PIN	SYMBOL	DESCRIPTION	REMARKS
1	Vss	GND	
2	Vdd	Power supply for LCM	5.0V
3	V0	Contrast Adjust	
4	RS	Register Select Signal	
5	R/W	Data Read / Write	
6	E	Enable Signal	
7	DB0	Data bus line	
8	DB1	Data bus line	
9	DB2	Data bus line	
10	DB3	Data bus line	
11	DB4	Data bus line	
12	DB5	Data bus line	
13	DB6	Data bus line	
14	DB7	Data bus line	
15	LED+	Power supply for BKL	5.0V
16	K(R)	Power supply for BKL	0V
17	K(G)	Power supply for BKL	0V
18	K(B)	Power supply for BKL	0V

BLOCK DIAGRAM

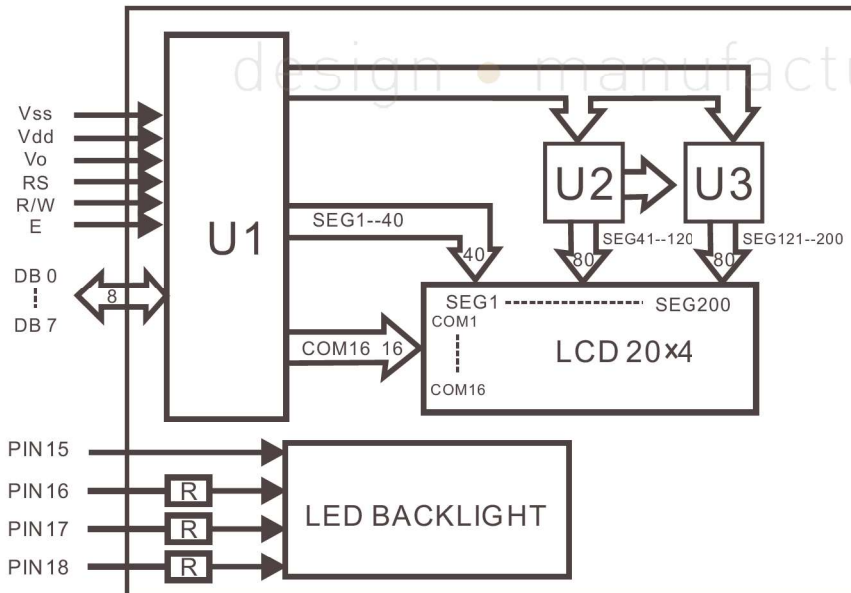

POWER SUPPLY DIAGRAM

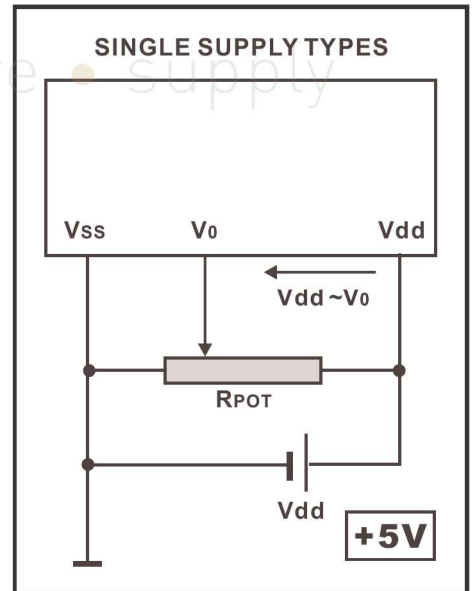

Upper 4bit Lower 4bit	LLLL	LLLH	LLHL	LLHH	LHLL	LHLH	LHHL	LHHH	HLLL	HLLH	HLHL	HLHH	HHLL	HHLH	HHHL	HHHH
LLLL	CG RAM (1)															
LLLH	(2)															
LLHL	(3)															
LLHH	(4)															
LHLL	(5)															
LHLH	(6)															
LHHL	(7)															
LHHH	(8)															
HLLL	(1)															
HLLH	(2)															
HLHL	(3)															
HLHH	(4)															
HHLL	(5)															
HHLH	(6)															
HHHL	(7)															
HHHH	(8)															



