



SIRIUS SAFETY RELAY STANDARD SERIES DEVICE
 RELAY ENABLING CIRCUITS 3 NO CONTACTS +
 RELAY SIGNALING CIRCUIT 1 NC CONTACT US = 24
 V AC/DC SPRING-LOADED TERMINAL

Figure similar

General technical data:		
product brand name		SIRIUS
Product designation		safety relays
Design of the product		For autonomous safety applications
Protection class IP of the enclosure		IP20
Protection against electrical shock		finger-safe
Insulation voltage Rated value	V	300
Ambient temperature		
• during storage	°C	-40 ... +80
• during operation	°C	-25 ... +60
Air pressure acc. to SN 31205	kPa	90 ... 106
Relative humidity during operation	%	10 ... 95
Installation altitude at height above sea level maximum	m	2 000
Vibration resistance acc. to IEC 60068-2-6		5 ... 500 Hz: 0,75 mm
Shock resistance		10g / 11 ms
Surge voltage resistance Rated value	V	4 000
EMC emitted interference		IEC 60947-5-1, IEC 61000
Installation environment regarding EMC		This product is suitable for Class B environments and can also be used in domestic environments.
Overvoltage category		Installation category III
Degree of pollution		3
Number of sensor inputs 1-channel or 2-channel		1
Design of the cascading		none
Type of the safety-related wiring of the inputs		single-channel and two-channel
Product property cross-circuit-proof		Yes

Safety Integrity Level (SIL) • acc. to IEC 61508		SIL3
Performance level (PL) • acc. to EN ISO 13849-1		e
Category acc. to EN ISO 13849-1		4
Safe failure fraction (SFF)	%	99
PFHD with high demand rate acc. to EN 62061	1/h	0.0000000017
Average probability of failure on demand (PFDavg) with low demand rate acc. to IEC 61508	1/y	0.000001
T1 value for proof test interval or service life acc. to IEC 61508	y	20
Hardware fault tolerance acc. to IEC 61508		1
Safety device type acc. to IEC 61508-2		Type A
Number of outputs as contact-affected switching element • as NC contact — for signaling function instantaneous contact — for signaling function delayed switching — safety-related instantaneous contact — safety-related delayed switching • as NO contact — for signaling function instantaneous contact — for signaling function delayed switching — safety-related instantaneous contact		1 0 0 0 0 0 0 3
Number of outputs as contact-less semiconductor switching element • safety-related — delayed switching — instantaneous contact • for signaling function instantaneous contact		0 0 0
Stop category acc. to DIN EN 60204-1		0

General technical data:

Design of input • cascading input/functional switching • feedback input • Start input		No Yes Yes
Type of electrical connection Plug-in socket		No
Operating frequency maximum	1/h	360
Switching capacity current • of the NO contacts of the relay outputs — at DC-13		

— at 24 V	A	5
— at 115 V	A	0.2
— at 230 V	A	0.1
— at AC-15		
— at 115 V	A	5
— at 230 V	A	5
• of the NC contacts of the relay outputs		
— at DC-13		
— at 24 V	A	1
— at 115 V	A	0.2
— at 230 V	A	0.1
— at AC-15		
— at 115 V	A	1.5
— at 230 V	A	1.5
Thermal current of the switching element with contacts maximum	A	5
Operating current at 17 V minimum	mA	5
Mechanical service life (switching cycles) typical		10 000 000
Design of the fuse link for short-circuit protection of the NO contacts of the relay outputs required		gL/gG: 6A or circuit breaker type A: 3A or circuit breaker type B: 2A or circuit breaker type C: 1A
Design of the fuse link for short circuit protection of the NC contacts of the relay outputs required		Diazed or Neozed fuses, operating class gL/gG: 6 A or MCB type A: 2 A or MCB type B: 2 A or MCB type C: 1 A
Cable length		
• for total of all sensor circuits with Cu 1.5 mm ² and 150 nF/km maximum	m	2 000
Make time with automatic start		
• typical	ms	200
• for DC maximum	ms	320
• with AC maximum	ms	320
Make time with automatic start after power failure		
• typical	ms	200
• maximum	ms	320
Make time with monitored start		
• maximum	ms	20
• typical	ms	15
Backslide delay time after opening of the safety circuits typical	ms	10
Backslide delay time in the event of power failure		
• typical	ms	65
• maximum	ms	75
Recovery time after opening of the safety circuits typical	ms	10

Recovery time after power failure typical	s	0.09
Pulse duration		
• of the sensor input minimum	ms	150
• of the ON pushbutton input minimum	s	0.015

Control circuit/ Control:

Type of voltage of the control supply voltage		AC/DC
Control supply voltage frequency		
• 1 Rated value	Hz	50
• 2 Rated value	Hz	60
Control supply voltage		
• for DC		
— Rated value	V	24
• with AC		
— at 50 Hz		
— Rated value	V	24
— at 60 Hz		
— Rated value	V	24
Operating range factor control supply voltage rated value of the magnet coil		
• with AC		
— at 50 Hz		0.85 ... 1.1
— at 60 Hz		0.85 ... 1.1
• for DC		0.85 ... 1.2
Active power loss typical	W	2

Installation/ mounting/ dimensions:

mounting position		any
Required spacing for grounded parts at the side	mm	5
Required spacing with side-by-side mounting at the side	mm	0
Mounting type		screw and snap-on mounting
Width	mm	22.5
Height	mm	100
Depth	mm	121.6

Connections/ Terminals:

Type of electrical connection		spring-loaded terminals
Type of connectable conductor cross-section		
• solid		1x (0.5 ... 1.5 mm ²), 2x (0.5 ... 1.5 mm ²)
• finely stranded		
— with core end processing		1x (0.5 ... 1.0 mm ²), 2x (0.5 ... 1.0 mm ²)
— without core end processing		1x (0.5 ... 1.5 mm ²), 2x (0.5 ... 1.5 mm ²)

Type of connectable conductor cross-section for AWG conductors		
<ul style="list-style-type: none"> • solid • stranded 		1x (20 ... 16), 2x (20 ... 16) 1x (20 ... 16), 2x (20 ... 16)

Product Function:

Product function parameterizable		Sensor floating / sensor non-floating, monitored start / autostart
Suitability for operation Device connector 3ZY12		No
Suitability for interaction press control		No
Suitability for use		
<ul style="list-style-type: none"> • safety switch • Monitoring of floating sensors • Monitoring of non-floating sensors • magnetically operated switch monitoring • safety-related circuits 		Yes Yes Yes Yes Yes

Certificates/ approvals:

General Product Approval	EMC	Functional Safety/Safety of Machinery	Declaration of Conformity
--------------------------	-----	---------------------------------------	---------------------------



[Type Examination](#)



Test Certificates	other
-------------------	-------

[Type Test Certificates/Test Report](#)

[Confirmation](#)

Further information

Information- and Downloadcenter (Catalogs, Brochures,...)

<http://www.siemens.com/industrial-controls/catalogs>

Industry Mall (Online ordering system)

<http://www.siemens.com/industrymall>

Cax online generator

<http://support.automation.siemens.com/WW/CAXorder/default.aspx?lang=en&mlfb=3SK11112AB30>

Service&Support (Manuals, Certificates, Characteristics, FAQs,...)

<http://support.automation.siemens.com/WW/view/en/3SK11112AB30/all>

Image database (product images, 2D dimension drawings, 3D models, device circuit diagrams, EPLAN macros, ...)

<http://www.automation.siemens.com/bilddb/index.aspx?attID9=3SK11112AB30&lang=en>

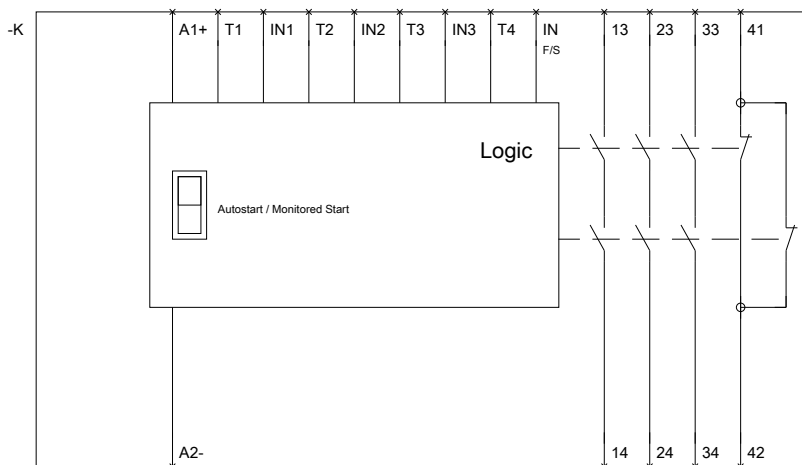
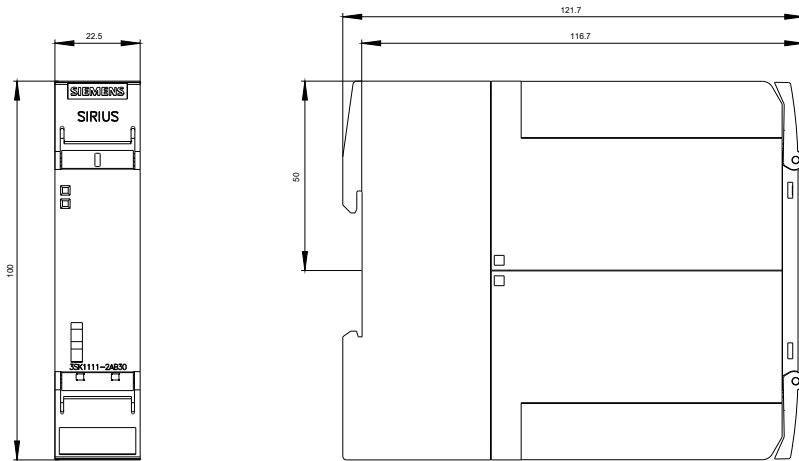

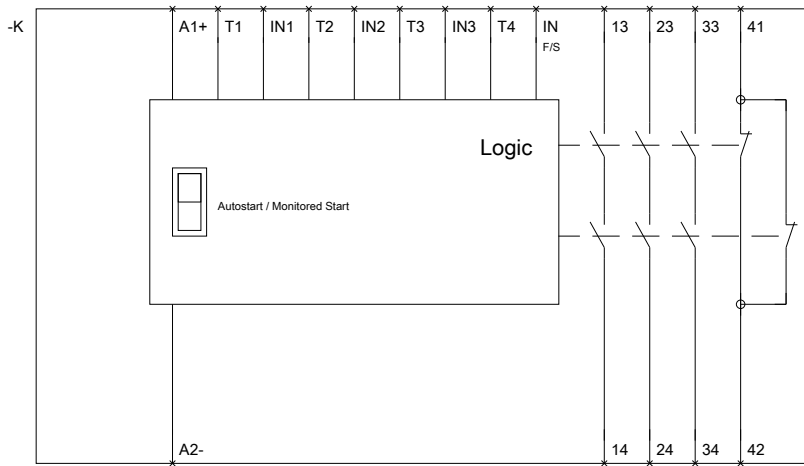

last modified:

09.03.2015