

MCP73871 click

PID: MIKROE-2858

MCP73871 click is a fully integrated solution for system power delivery and Li-Po/Li-Ion battery charge management. The click features many Li-Po/Li-Ion battery charging optimizations, used to maximize the battery life. Some of the MCP73871 click features include constant current and voltage charging algorithms, overvoltage protection, automatic end of charge control, automatic recharge feature, preconditioning for depleted cells and thermal management.

All these features, coupled with the ability to simultaneously power up the system load and charge the connected battery, make this click a perfect solution for powering up many different battery-operated builds and projects, which use a rechargeable Li-Po/Li-Ion battery, but can also switch to an external power source.

How does it work

MCP73871 click uses the [MCP73871](#) device, a system load sharing and Li-Po/Li-Ion battery charge management integrated circuit from [Microchip](#). This device completely manages the power distribution, utilizing many different steps in this process.

The input voltage is constantly monitored and with no battery connected or with a battery element which is deeply depleted, the power to the connected load will be delivered straight from the external power supply, provided from the 5V rail of the mikroBUS™ socket. The current that can be delivered in

this mode, depends on the limiting factor selected by the PRG2 pin. If the PRG2 pin is set to a LOW logic level, the current will be limited to 80mA - 100mA. If the PRG2 pin is set to a HIGH logic level, the current supplied to the load will be limited to 400mA - 500mA.

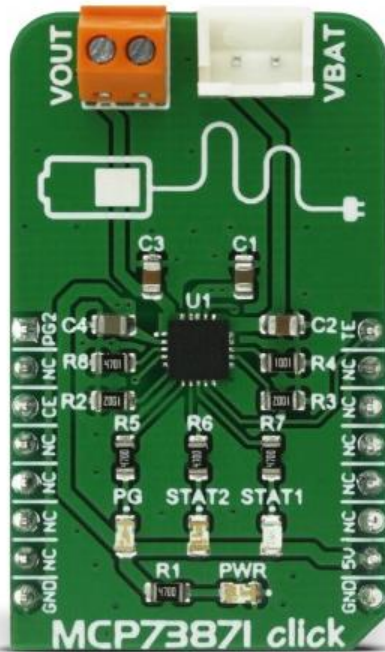

There are several conditions set by the MCP73871 device, that define the behavior of the power management logic. If there is a Li-Po/Li-Ion battery connected to the battery connector, the charging procedure will go through the following steps:

- If the connected battery is deeply depleted and the CE (Charge Enable) pin is set to a HIGH logic level, the preconditioning mode is activated. The charging current is only a fraction of the regulated charging current, used for fast charging, preventing battery damage and overheating.
- If the battery voltage is above the preconditioning threshold voltage set by the MCP73871 device, the fast charging will begin, and the charging current is set by the PRG2 pin, like described above and a voltage equal to 4.35V, as per factory settings of the MCP73871 IC.

- When the charging complete conditions are met, the charger circuit will stop the charging process. The battery voltage is monitored, and when it falls under the recharge threshold, another charging cycle will be repeated.
- During all the charging modes, the temperature of the MCP73871 die is monitored, so the charging current is regulated accordingly. The over temperature protection will put the device in the shutdown mode, preventing damage.
- If the Timer is enabled by the TE pin, it will be used to limit the charging time, if the battery voltage never reaches the end-of-charge condition.

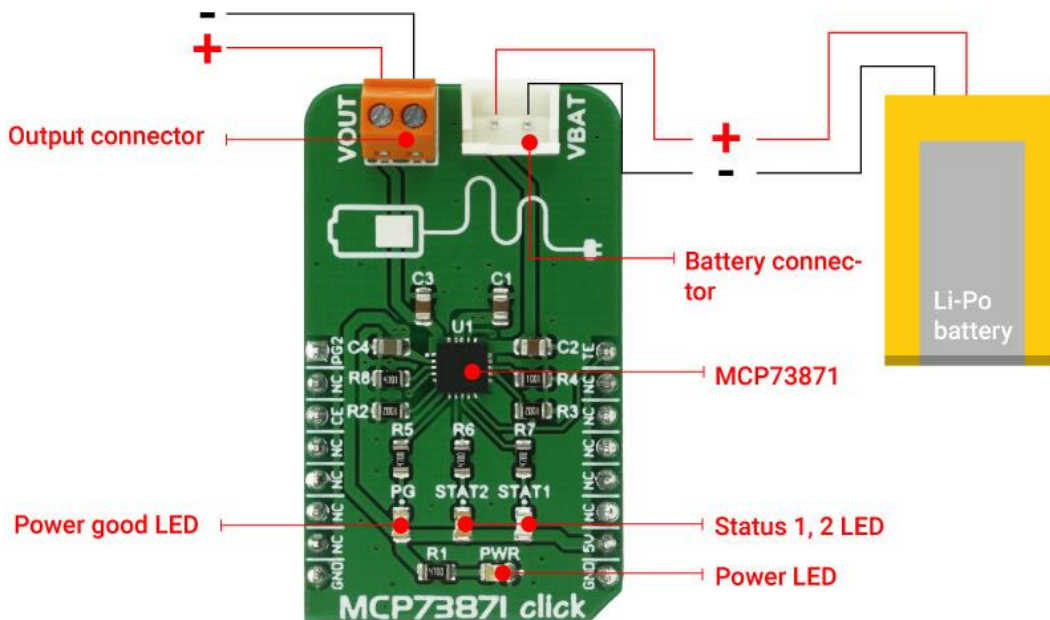

The MCP73871 power-sharing system logic, enables to simultaneously charge and power up the system load, connected to the onboard output screw terminal. The power-sharing system is active at all times and always prioritizes connected load over the battery charging. Li-Po/Li-Ion battery can be connected to the onboard 2.54mm two-pin header. There are three LEDs that are used to indicate power good status, as well as the charging status. The status LED signalization is explained in the Status LED table, below.

Specifications

Type	Battery charger
Applications	A perfect solution for powering up many different battery-operated builds and projects, which are powered up by a rechargeable Li-Po/Li-Ion battery, but can also switch to an external power source while charging the battery.
On-board modules	Microchip's MCP73871 - Stand-Alone System Load Sharing and Li-Ion/Li-Po Battery Charge Management Controller
Key Features	Ability to simultaneously power up the system load and charge the connected Li-Ion/Li-Po battery by applying optimized battery charging algorithm.
Interface	GPIO
Input Voltage	5V
Click board size	M (42.9 x 25.4 mm)

Pinout diagram

This table shows how the pinout on **MCP73871** [click](#) corresponds to the pinout on the mikroBUS™ socket (the latter shown in the two middle columns).

Notes	Pin					Pin	Notes
Set Charging Current	PG2	1	AN	PWM	16	TE	Enable Safety Timer
	NC	2	RST	INT	15	NC	
Charge Enable	CE	3	CS	RX	14	NC	
	NC	4	SCK	TX	13	NC	
	NC	5	MISO	SCL	12	NC	
	NC	6	MOSI	SDA	11	NC	
	NC	7	3.3V	5V	10	+5V	Power Supply
Ground	GND	8	GND	GND	9	GND	Ground

MCP73871 click electrical specifications

Description	Min	Typ	Max	Unit
Charge Current (if PG2 is low)	80		100	mA
Charge current (if PG2 is high)	400		500	mA

Onboard settings and indicators

Label	Name	Default	Description
LD1	PWR	-	Power LED indicator, green
LD2	PG	-	Power good LED, blue
LD3	STAT2	-	Status LED, green
LD4	STAT1	-	Status LED, red
J1	VBAT	-	Battery connector
TB1	VOUT	-	External load connector

Status LEDs table

Charge Cycle State	STAT1	STAT2	PG
Shutdown (VCC=VBAT)	Off	Off	Off
Shutdown (CE=L)	Off	Off	On
Preconditioning	On	Off	On
Constant Current	On	Off	On
Constant Voltage	On	Off	On
Charge Complete - Standby	Off	On	On
Temperature Fault	On	On	On
Timer Fault	On	On	On
Low Battery Output	On	Off	Off
No Battery Present	Off	Off	On
No Input Power Present	Off	Off	Off