

50 W converter using HVLED101 quasi-resonant HPF flyback controller with primary side regulation

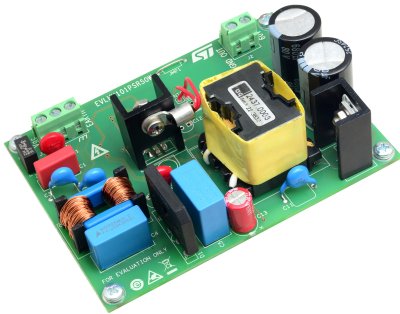

Product status link

[EVLHV101PSR50W](#)

Features

- Input voltage: V_{in} : 90 - 265 Vrms, f: 45-66 Hz
- Output voltage 60 V / 833 mA
- High power factor, low THD
- Efficiency > 50% in stand-by ($P_{out} = 240$ mW)
- 4 points (25%, 50%, 75%, 100% load) average efficiency > 91%
- Frequency foldback with valley locking for noise-free operation
- $T_{AMB-MAX} = 60$ °C
- Open load voltage limiting (< 65V)
- Short-circuit protection with auto restart
- NTC overtemperature protection for switching MOSFET
- Safety: Acc. to EN60065
- EMI: Acc. to EN55022 – conducted emissions
- RoHS compliant

Description

The **EVLHV101PSR50W** is intended to provide a stable and insulated 60 V voltage for a maximum power of 50 W.

It can be used as a standalone power supply or as a front end stage in a dimmable (or non-dimmable) off line LED driver.

A very high power factor, low THD and low BOM cost are obtained from this demonstration board thanks to the features of the HVLED101, which adopts frequency foldback with valley locking operation to reduce the switching losses and minimize acoustic noise.

Extremely low input power is obtained at no-load.

Input voltage variations, excessive input voltage (overvoltage like surges or bursts) and insufficient input voltage are managed by the HVLED101 protections, which improve the reliability of the application.

Output short-circuit and overload protection with auto restart behavior is implemented.

1 Components placement

Figure 1. EVLHV101PSR50W – top components placement

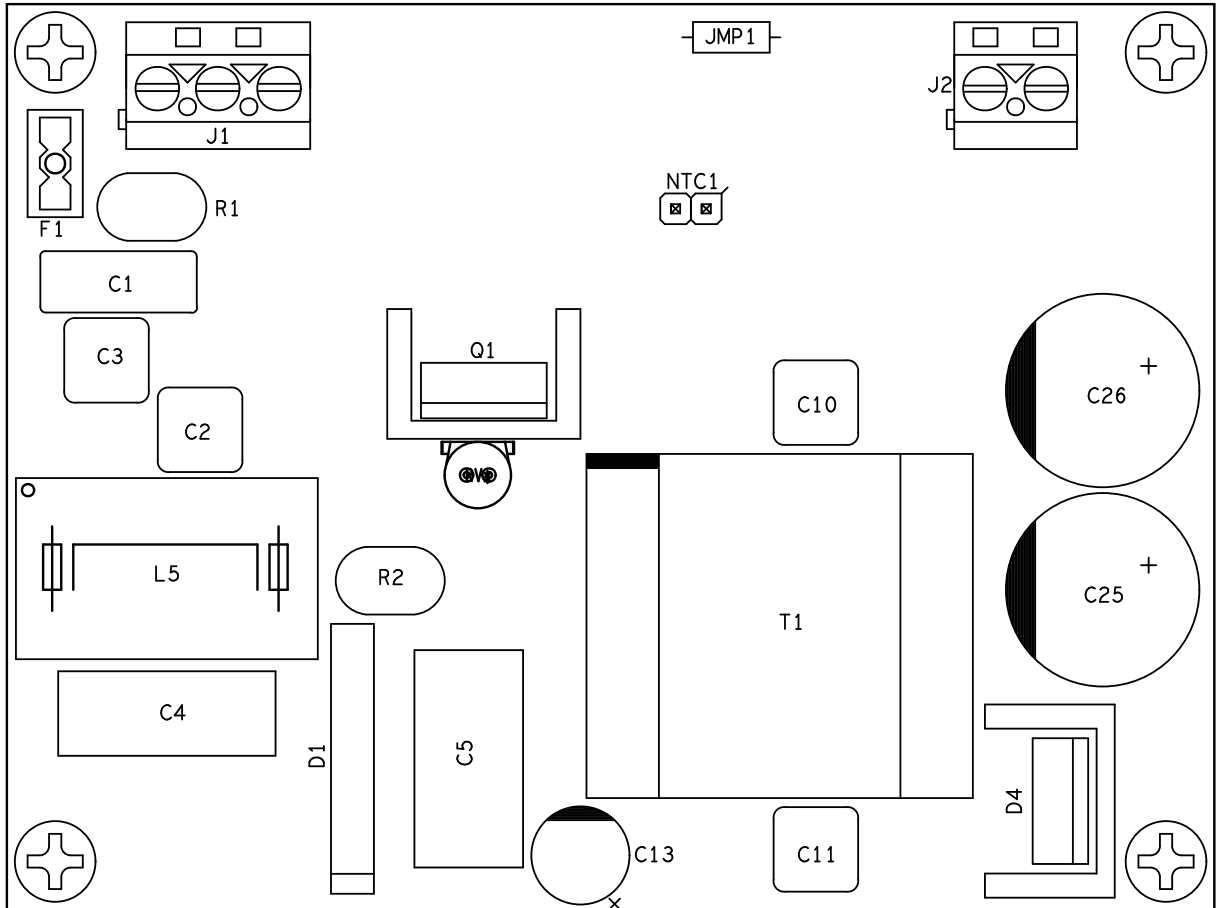
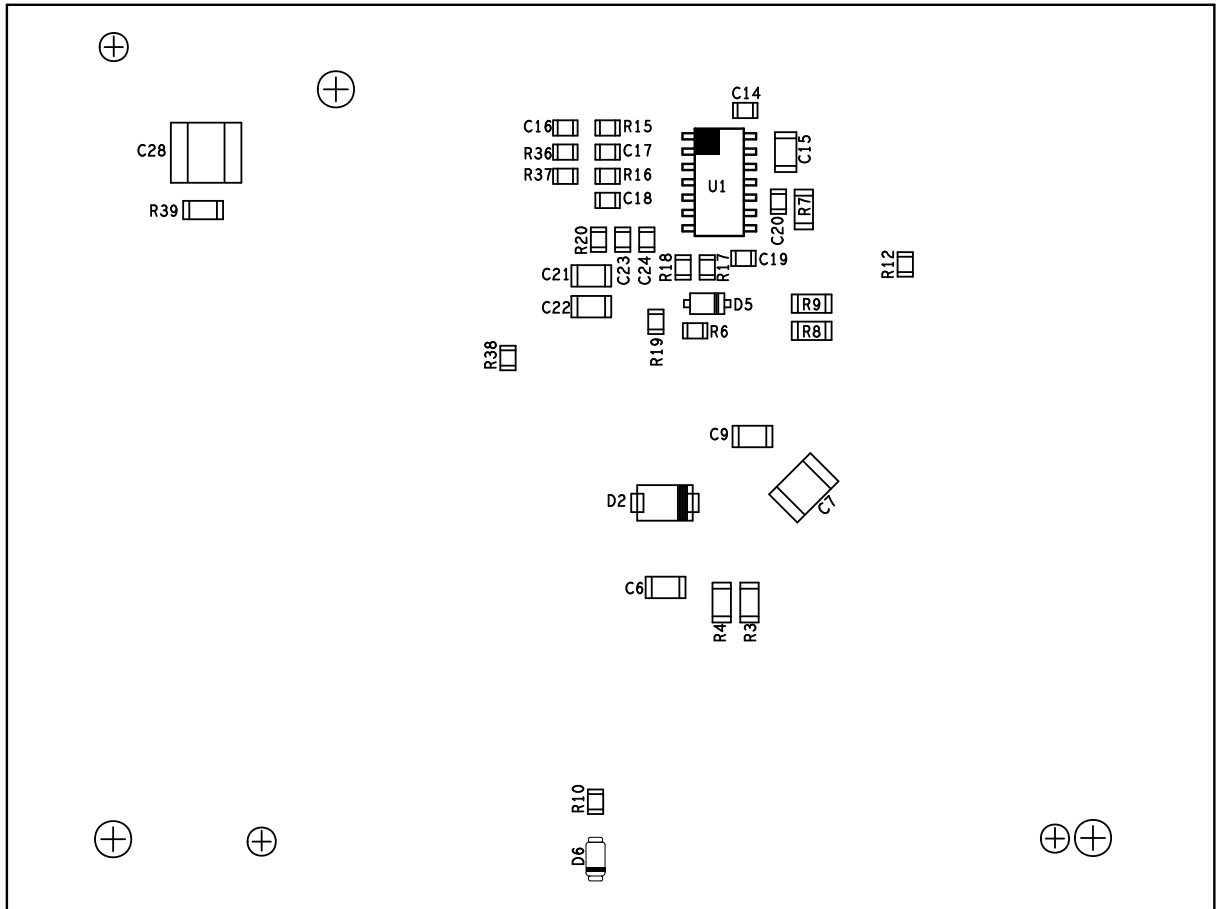
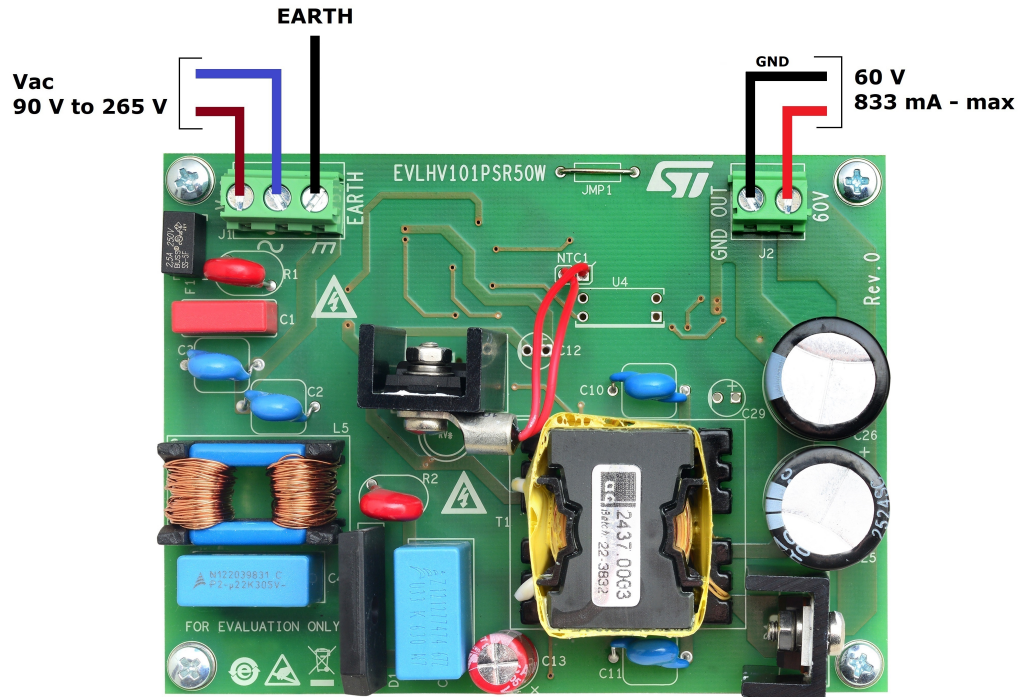

Figure 2. EVLHV101PSR50W – bottom components placement



2 Connector map

Figure 3. Connector map

Table 1. Connector map

Ref.	Pin #	Name	Type	Description
J1	1	Vac	Input	First connection to AC mains – Warning high voltage
	2	Vac	Input	Second connection to AC mains – Warning high voltage
	3	EARTH	Input	Earth connection
J2	1	GND	Output	Ground
	2	60V	Output	60V output (isolated)

3 Schematic diagram

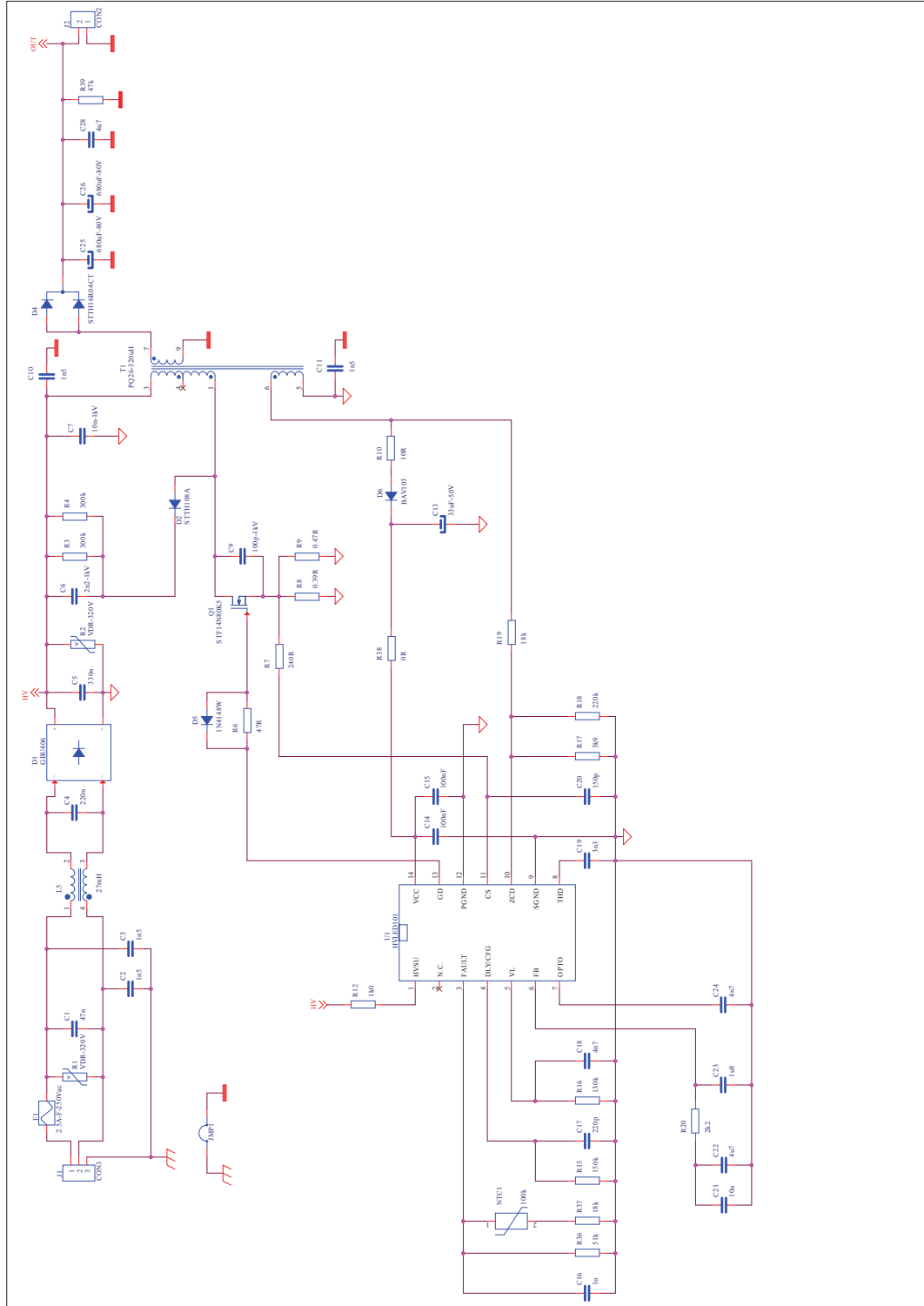
Figure 4. EVLHV101PSR50W schematic



4 Bill of material

Table 2. Bill of material

Item	Q.ty	Ref. Des.	Value - Rating	Description	Manufacturer	Part number
1	1	C1	47n - 305VAC	X2 film capacitor 305VAC (MKP)	Wurth	890334023015CS
2	2	C2,C3	1n5	X1-Y2 ceramic capacitor 440-300VAC CS series	TDK	CS75ZU2GA152MANKA
3	1	C4	220n - 305VAC	X2 film capacitor 305VAC (MKP)	TDK	B32922C3224K
4	1	C5	330n	Polypropylene film capacitor 630VDC-310VAC	TDK	B32672Z6334K000
5	1	C6	2n2-1kV	Multilayer ceramic capacitor X7R 1kV	AVX	1206AC222KAT1A
6	1	C7	10n-1kV	Multilayer ceramic capacitor X7R 1kV	AVX	1812AC103KAT1A
7	1	C9	100p-1kV	Multilayer ceramic capacitor C0G 1kV	AVX	1206AA101JAT1A
8	2	C10,C11	1n5 - 400VAC	X1-Y1 ceramic capacitor 440-400 VAC CD series	TDK	CD45-E2GA152M-NKA
9	1	C13	33u-50V	Aluminium ELCAP - YXF series- 105°C	Wurth	860240674004
10	1	C14	100n - 50V	Cercap P X7R - SMD-0805	---	---
11	1	C15	100n - 50V	Cercap X7R - SMD-1206	---	---
12	1	C16	1n - 50V	Cercap X7R - SMD-0805	---	---
13	1	C17	220p - 50V	Cercap C0G - SMD-0805	---	---
14	2	C18,C24	4n7 - 50V	Cercap X7R - SMD-0805	---	---
15	1	C19	3n3 - 50V	Cercap X7R - SMD-0805	---	---
16	1	C20	150p - 50V	Cercap C0G - SMD-0805	---	---
17	1	C21	10u - 25V	Cercap X7R - SMD-1206	---	---
18	1	C22	4u7 - 25V	Cercap X7R - SMD-1206	---	---
19	1	C23	1u8 - 25V	Cercap X7R - SMD-0805	---	---
20	2	C25,C26	680uF-80V	Aluminium ELECAP FS series105°C	Panasonic	EEUFS1K681
21	1	C28	4u7 - 100V	Cercap X7R - SMD-2020	AVX	22201C475KAT2A
22	1	D1	---	4A glass passivated bridge rectifier - GBU	Diodes Incorporated	GBU406

Item	Q.ty	Ref. Des.	Value - Rating	Description	Manufacturer	Part number
23	1	D2	---	High voltage ultrafast rectifier 800V - SMA	STMicroelectronics	STTH108A
24	1	D4	---	2X ultrafast recovery diode 400V - TO220AB	STMicroelectronics	STTH16R04CT
25	1	D5	---	Small signal switching diode- SOD-123	Vishay	1N4148W
26	1	D6	---	Small signal switching diode - SOD80 (minimelf)	Vishay	BAV103-GS18
27	1	F1	2.5A-250VAC	FUSE SS-5F series 2.5A-250VAC fast acting	Bussmann	SS-5F-2.5A
28	1	J1	---	PCB connector 3 PIN	Weidmuller	PM 5.08/03/90 3.5SN BK BX - 1760520000
29	1	J2	---	PCB connector 2 PIN	Weidmuller	PM 5.08/02/90 3.5SN BK BX - 1760510000
30	1	JMP1	---	Tinned copper wire jumper DIA 0.7MM	---	---
31	1	L5	27mH	27mH common mode choke filter	Epcos	B82732F2901B001
32	1	NTC1	100k	NTC - 100k - 1% - wired thermostat with metallic ring		NTCALUG01A104FA
33	1	Q1	---	N-channel power MOSFET 800V 0.4OHM	STMicroelectronics	STF14N80K5
34	2	R1,R2	VDR-320V	Metal-oxide varistor la series	Littelfuse	V320LA7P
35	2	R3,R4	300k - 200V	Stand. filmRES - 1/4W - 5% - SMD-1206	---	---
36	1	R6	47R - 150V	Stand. filmRES - 1/8W - 5% - SMD-0805	---	---
37	1	R7	240R - 200V	Stand. filmRES - 1/4W - 1% - SMD-1206	---	---
38	1	R8	0.39R - 200V	Stand. filmRES - 1/4W - 1% - SMD-1206	---	---
39	1	R9	0.47R - 200V	Stand. filmRES - 1/4W - 1% - SMD-1206	---	---
40	1	R10	10R	Stand. filmRES - 1/8W - 5% - SMD-0805	---	---
41	1	R12	1k0 - 150V	Stand. filmRES - 1/8W - 5% - SMD-0805	---	---
42	1	R15	150k - 150V	Stand. filmRES - 1/8W - 1% - SMD-0805	---	---
43	1	R16	130k - 150V	Stand. filmRES - 1/8W - 1% - SMD-0805	---	---
44	1	R17	3k9 - 150V	Stand. filmRES - 1/8W - 1% - SMD-0805	---	---
45	1	R18	220k - 150V	Stand. filmRES - 1/8W - 1% - SMD-0805	---	---
46	2	R19, R37	18k - 150V	Stand. filmRES - 1/8W - 1% - SMD-0805	---	---

Item	Q.ty	Ref. Des.	Value - Rating	Description	Manufacturer	Part number
47	1	R20	2k2 - 150V	Stand. filmRES - 1/8W - 1% - SMD-0805	---	---
48	1	R36	51k - 150V	Stand. filmRES - 1/8W - 5% - SMD-0805	---	---
49	1	R38	0R	Stand. filmRES - SMD-0805	---	---
50	1	R39	47k - 200V	Stand. filmRES - 1/4W - 1% - SMD-1206	---	---
51	1	T1	---	PQ26/22.5 flyback transformer 320uH	Magnetics	Custom
52	1	U1	---	High power factor controller - HVLED101	STMicroelectronics	HVLED101

5 Board performance

Table 3. Efficiency table (Vout = 60 V)

Load [%]	Iout [mA]	@ VIN = 115 V _{AC}	@ VIN = 230 V _{AC}
25	208	91.0%	90.2%
33	278	91.7%	91.2%
50	417	92.0%	91.8%
75	625	92.0%	92.4%
100	833	91.7%	92.6%
4 points avg.		91.7%	91.7%

Table 4. No-load & standby consumption

Condition	@ VIN = 115 V _{AC}	@ VIN = 230 V _{AC}
No load	185 mW	132 mW
Stand-by (Pout=240mW)	419 mW	415 mW

Revision history

Table 5. Document revision history

Date	Version	Changes
24-Nov-2022	1	Initial release.

Contents

1	Components placement	2
2	Connector map	4
3	Schematic diagram	5
4	Bill of material	6
5	Board performance	9
	Revision history	10
	List of tables	12
	List of figures	13

List of tables

Table 1.	Connector map	4
Table 2.	Bill of material	6
Table 3.	Efficiency table (Vout = 60 V).	9
Table 4.	No-load & standby consumption	9
Table 5.	Document revision history	10

List of figures

Figure 1.	EVLHV101PSR50W – top components placement	2
Figure 2.	EVLHV101PSR50W – bottom components placement.	3
Figure 3.	Connector map.	4
Figure 4.	EVLHV101PSR50W schematic.	5

IMPORTANT NOTICE – READ CAREFULLY

STMicroelectronics NV and its subsidiaries (“ST”) reserve the right to make changes, corrections, enhancements, modifications, and improvements to ST products and/or to this document at any time without notice. Purchasers should obtain the latest relevant information on ST products before placing orders. ST products are sold pursuant to ST’s terms and conditions of sale in place at the time of order acknowledgment.

Purchasers are solely responsible for the choice, selection, and use of ST products and ST assumes no liability for application assistance or the design of purchasers’ products.

No license, express or implied, to any intellectual property right is granted by ST herein.

Resale of ST products with provisions different from the information set forth herein shall void any warranty granted by ST for such product.

ST and the ST logo are trademarks of ST. For additional information about ST trademarks, refer to www.st.com/trademarks. All other product or service names are the property of their respective owners.

Information in this document supersedes and replaces information previously supplied in any prior versions of this document.

© 2022 STMicroelectronics – All rights reserved