

Typ-Nr.	E13278	E13279	E13280	E13281	E13282	E13283
	E13284	E13285	E13286	E13287	E13288	E13289
	E13290	E13291	E13292	E13293		
	E13338	E13339	E13340	E13341	E13342	E13343
	E13344	E13345	E13346	E13347	E13348	E13349
	E13350	E13351	E13352	E13353		
	E14483	E14484	E14485	E14486		

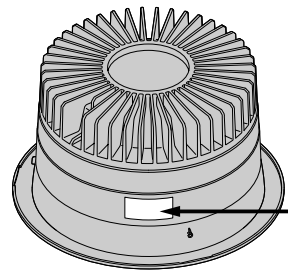
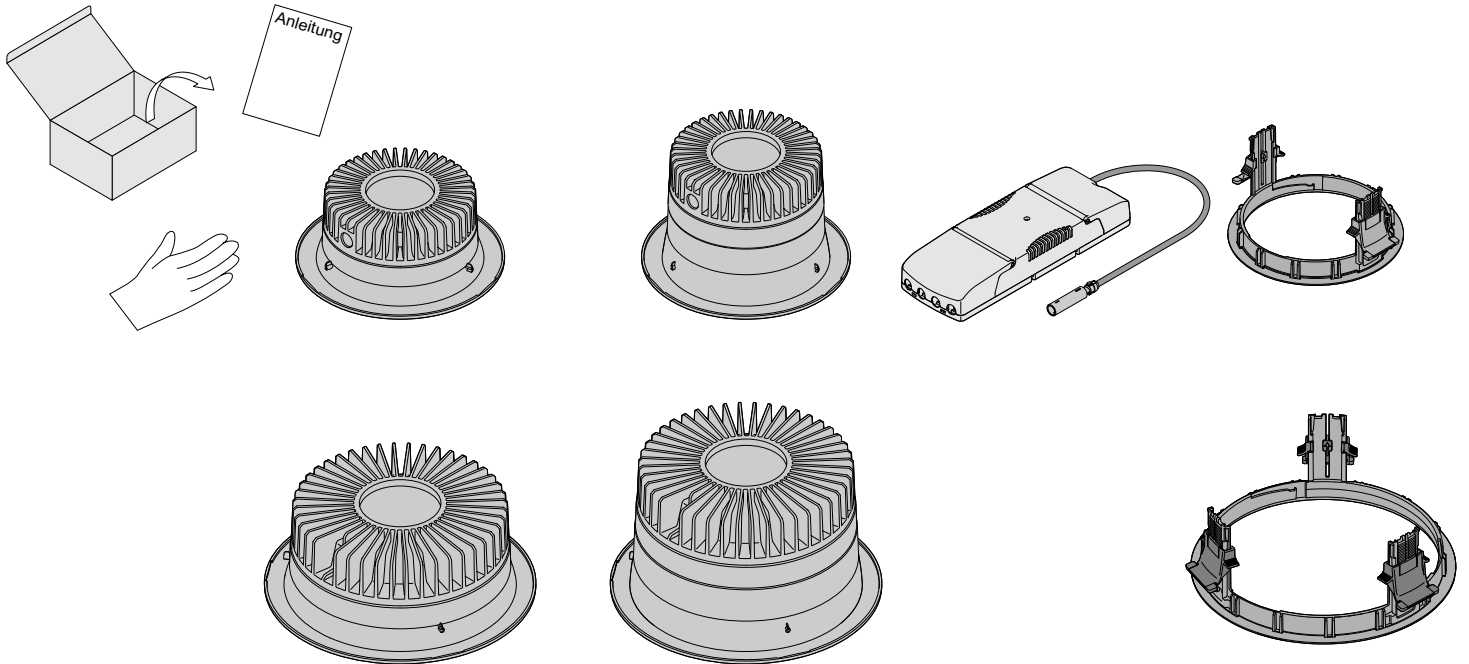
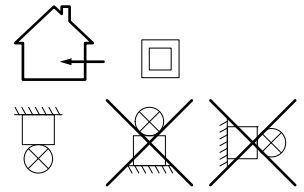

ZUMTOBEL

CE EAC

Mod
Ser
Typ

IP20
↓
↑
IP44

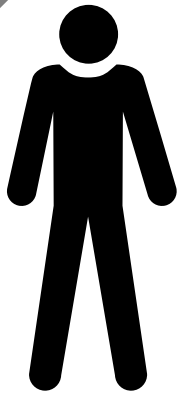

DE Die Montage und Inbetriebnahme darf nur von autorisiertem Fachpersonal durchgeführt werden.

GB Installation and commissioning may only be carried out by authorized specialists.

FR L'installation et la mise en service doivent obligatoirement être effectuées par des techniciens.

IT Montaggio ed avviamento devono essere eseguiti solo da personale specializzato.

NL De montage en inbedrijfstelling mogen enkel door erkend vakpersoneel worden uitgevoerd.

NO/SE Monteringen och idrifttagandet får endast företas av auktoriserad fackpersonal.

FI Asennuksen ja käyttöönoton saa tehdä vain auktorisoitu ammattihenkilöstö.

ES El montaje y la puesta en marcha sólo puede ser realizado por personal especializado autorizado.

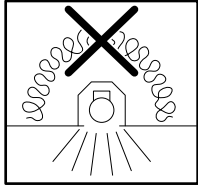
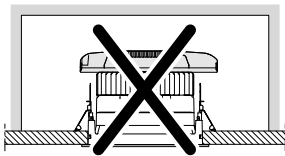

DE Leuchte darf nicht mit Wärmedämmung abgedeckt werden.

GB Luminaire not suitable for covering with thermally insulating material.

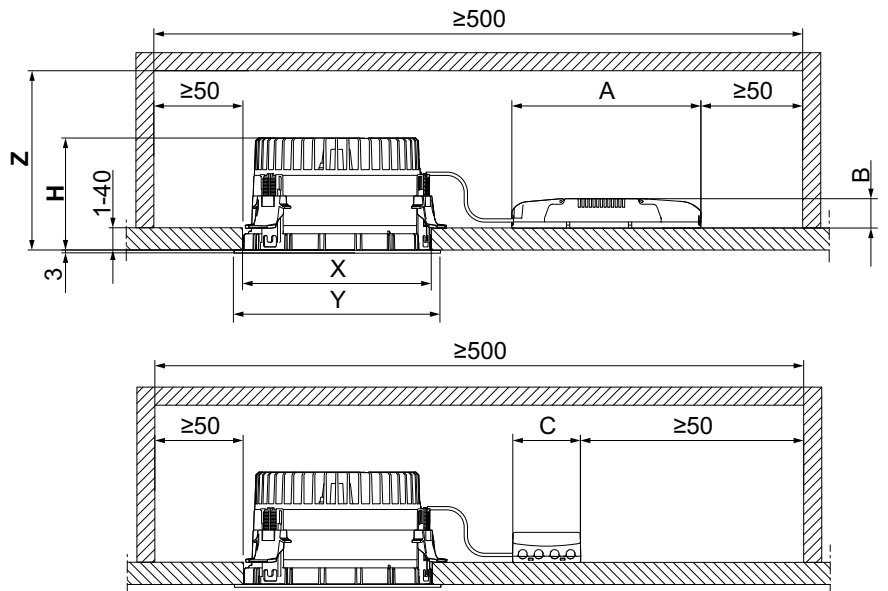

PANOS EVO...	X (mm)	Y (mm)	H (mm)	Z (mm)
R150 L	Ø150	Ø168	65	81
R150 H	Ø150	Ø168	103	113
R200 L	Ø200	Ø218	79	89
R200 H	Ø200	Ø218	119	129

	A (mm)	B (mm)	C (mm)
	max. 235	max. 31	max. 100

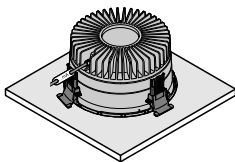

DE Die Leuchte dient ausschließlich der Beleuchtung und ist entsprechend den nationalen Errichtungsbestimmungen zu installieren. Eine andere Nutzung oder ein anderer Einbau gilt als „nicht bestimmungsgemäß“.

GB The luminaire is used exclusively for lighting and is to be installed in accordance with the national installation regulations. Any other use or installation is regarded as "not according to instructions".

FR Le luminaire sert uniquement à l'éclairage et doit être installé conformément aux prescriptions nationales en matière d'installation. Toute autre utilisation ou installation est considérée comme "non conforme".

IT L'apparecchio è destinato esclusivamente all'illuminazione e va installato in conformità alle leggi nazionali in vigore. Un altro impiego o un diverso tipo di montaggio non è considerato conforme alle disposizioni.

NL De lamp dient uitsluitend voor de verlichting en dient conform de nationale bouwbevelingen te worden geïnstalleerd. Een ander gebruik of een andere inbouw is niet conform.

NO/SE Armaturen är uteslutande avsedd för belysning och ska installeras i enlighet med de nationella installationsbestämmelserna. All annan användning eller montering gäller som "icke ändamålsenlig".

FI Valaisin on tarkoitettu ainoastaan valaistuskäyttöön, ja se on asennettava kansallisten määräysten mukaan. Muu käyttö tai muu asennus katsotaan sopimuksenvastaiseksi käytöksi.

ES La lámpara está destinada exclusivamente a la iluminación y debe ser instalada de acuerdo con las pertinentes normas nacionales. Cualquier otro uso o instalación no se considerará "previsto por la norma".

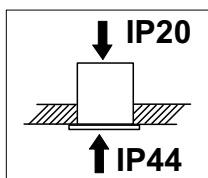

DE Voraussetzung für die Schutzart IP 44 der Leuchte ist die Installation in einer geschlossenen Decke! Die Schutzart IP 44 gilt nur von der Raumseite her.

GB The luminaire is protection type IP 44, only when being installed in an enclosed ceiling! Protection type IP 44 does not apply in the ceiling void itself.

FR L'installation dans un plafond fermé est nécessaire pour qu'une réalisation soit IP 44. La protection IP 44 ne joue que par rapport à la pièce.

IT La premessa per il tipo di protezione IP 44 dei modelli è l'installazione in uno spazio chiuso! Il sistema di protezione IP 44 riguarda solamente gli spazi laterali dai quali fuoreisce il fascio di luce.

NL Voorwaarde voor di classificatie IP 44 van het armatuur is, de installatie in een gesloten plafond. De classificatie IP 44 geldt alleen voor de ruimtezijde

NO/SE Armaturen har kapslingsgrad IP 44 bare når den er bygget inn i tett undertak. IP 44 gjelder bare nedenfra (fra rommet).

FI Koteloituiluokka IP 44 pätee vain umpikattoon asennetulle valaisimelle. Koteloituiluokka IP 44 pätee vain huoneen puolelta.

ES La luminaria equipada cumple con la protección IP 44 cuando se encuentra instalada en un techo cerrado. La protección IP 44 concierne únicamente la zona de la luminaria vista desde el interior del local.

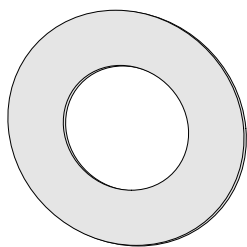

DE Bei dünnem oder weichem Deckenmaterial empfiehlt sich die Verwendung des Deckenverstärkungsringes zur Vergrößerung der Auflagefläche!

NL Bij dun of zacht plafondmateriaal is het gebruik van de plafondverstevigende ring ter vergroting van het draagvlak aanbevelenswaardig!!

GB With thin or soft ceiling material it is recommended that ceiling reinforcing rings should be used to enlarge the bearing surface.

NO/SE For svakt eller mykt tildekkingsmateriale anbefaler vi bruk av forsterkingsringer for å øke anleggsflaten!

FR On recommande l'utilisation de la bague de renfort de plafond pour agrandir la surface portante lorsque le matériau du plafond est mince ou souple.

FI Kattomateriaalin ollessa ohutta tai pehmeää on katonvahvistusringien käyttö suositeltavaa asetuspinna suurentamiseksi.

IT Con materiale coprente sottile o flessibile è consigliato l'impiego dell'anello di rinforzo della copertura per ingrandire la superficie d'appoggio!

ES En caso de material para cielorrasos fino o blando, se recomienda utilizar el aro de refuerzo de cielorrasos para agrandar la superficie de apoyo.

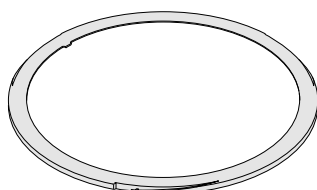

DE Montagering nur bei Zubehör

NL Montagering uitsluitend bij toebehoren

GB Mounting ring only for accessories

NO/SE Montagering bara vid tillbehör

FR Bague de montage avec accessoires uniquement

FI Kiinnitysrengas vain lisävarusteena

IT Anello di montaggio solamente per l'accessorio

ES Anillo de montaje sólo en caso de accesorios



FR **Attention!** Toujours travailler sans tension lors du câblage et de l'installation des luminaires et unités d'alimentation. Le non-respect de cette consigne peut entraîner la destruction des modules à LED.

NO/SE **OBS!** Koble alltid fra strømmen ved kabling og installasjon av lampene og strømforsyningsenhetene. LED-modulene kan ødelegges dersom dette ignoreres.

DE **Achtung!** Während der Verdrahtung und Installation der Leuchten und Versorgungsgeräte immer spannungslos arbeiten. Nichtbeachtung kann zur Zerstörung der LED-Module führen.

IT **Attenzione!** Lavorare sempre in assenza di tensione mentre si cablano e si installano gli apparecchi e le unità di alimentazione. In caso contrario i moduli LED possono andare distrutti!

FI **Huom!** Valaisimien ja syöttölaitteiden kytkemisen ja asentamisen aikana on aina työkenneltävä jännitteettömästi. Muutoin led-moduulit voivat tuhoutua.

GB **Caution!** Make sure that the luminaires and power supply units are always disconnected from the mains supply during wiring and installation work. Otherwise, the LED modules may be destroyed.

NL **Opgelet!** Tijdens het bedraden en installeren van de armaturen en voedingsapparaten altijd zonder spanning werken. Bij niet-naleving hiervan kunnen de LED-modules ernstig worden beschadigd.

ES **Atención** Siempre mantenga desconectada la tensión al realizar las tareas de cableado y de instalación de las luminarias y dispositivos de alimentación. De lo contrario podría destruirse el módulo LED.

1

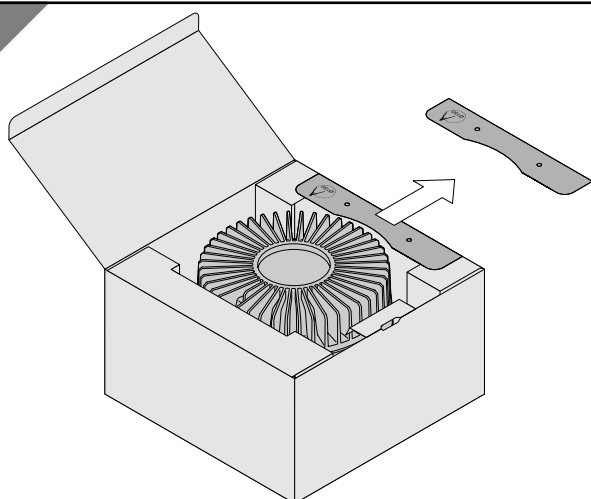

2

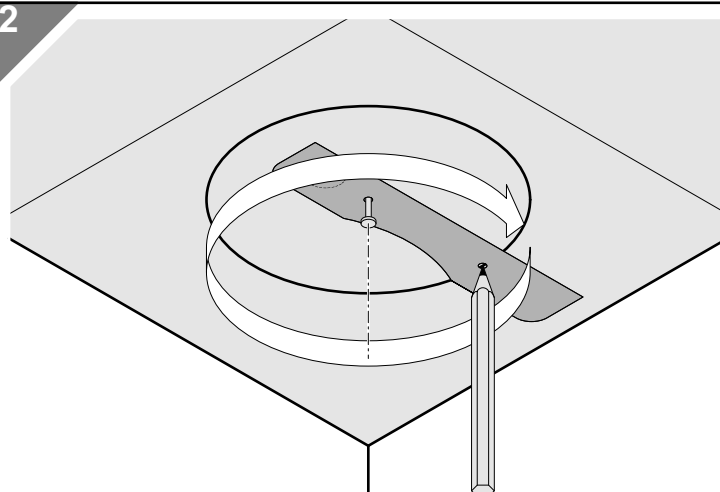

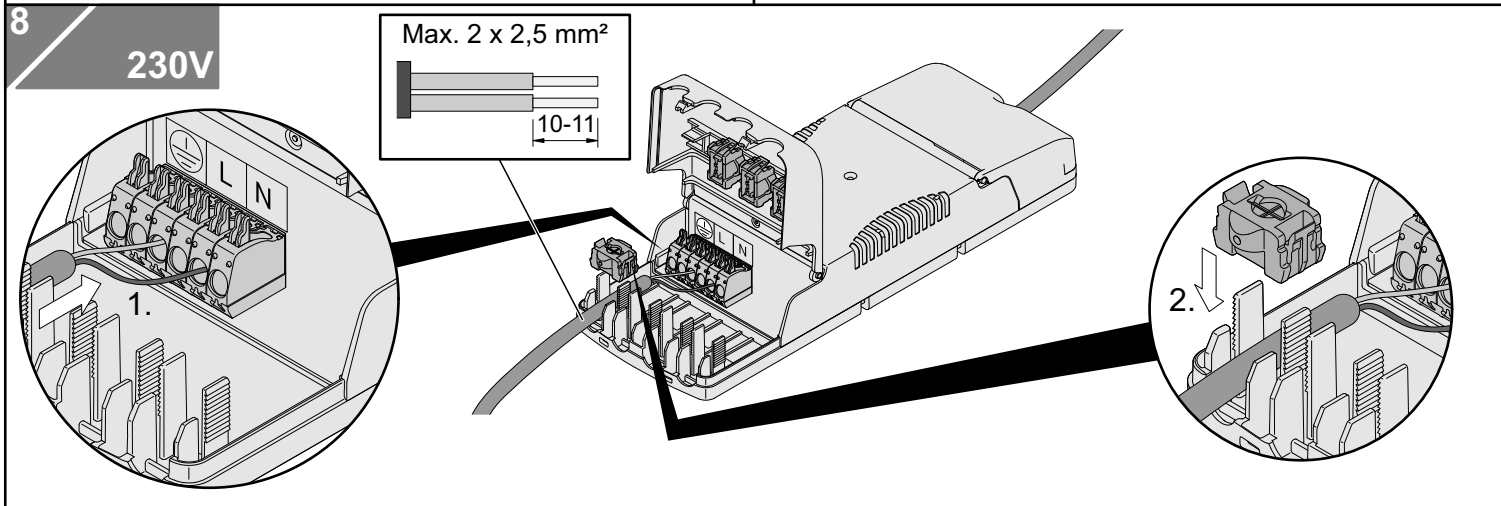
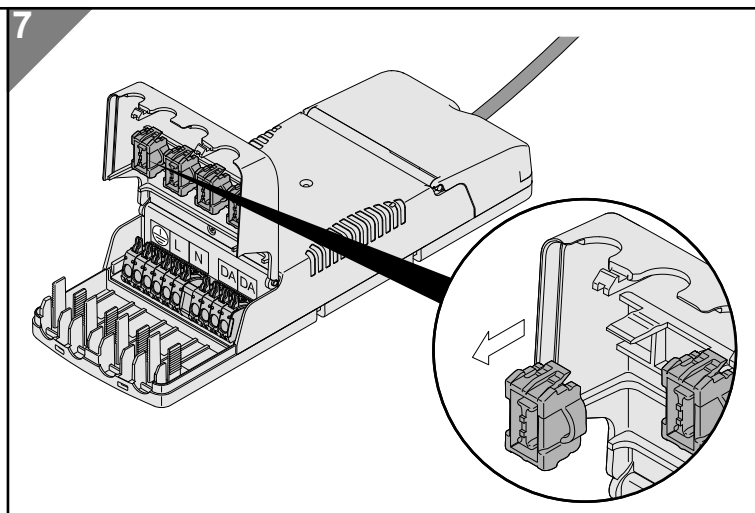
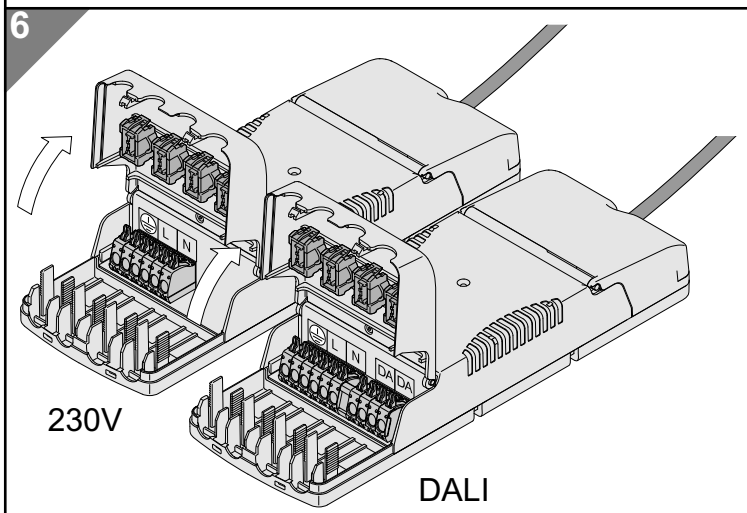
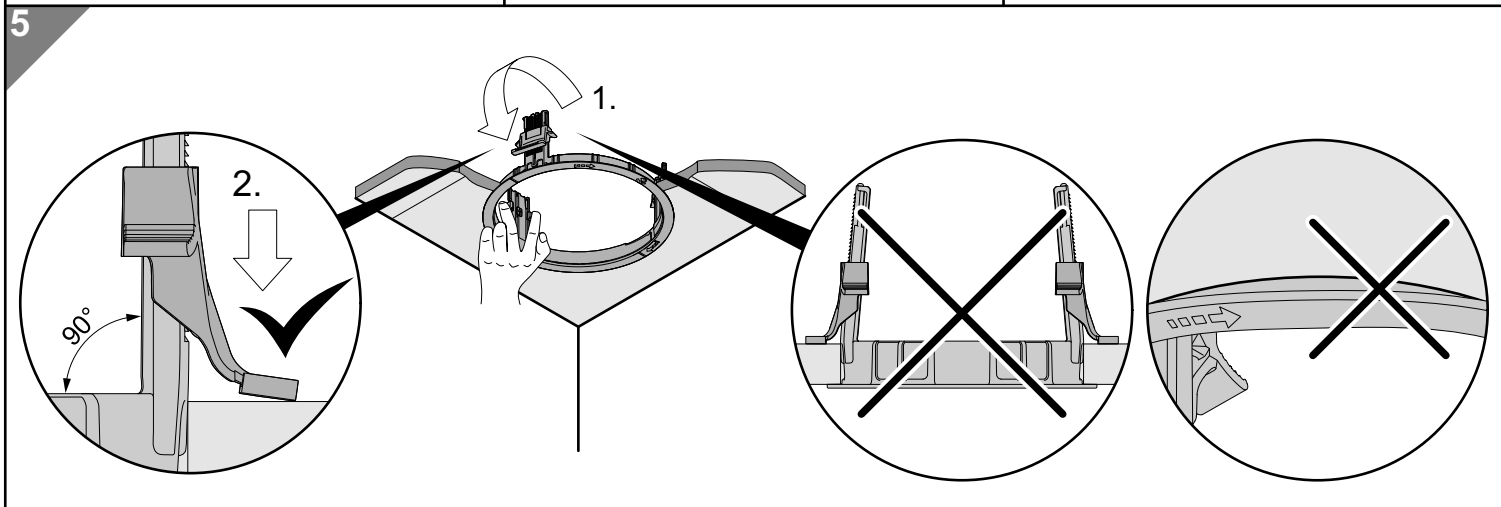
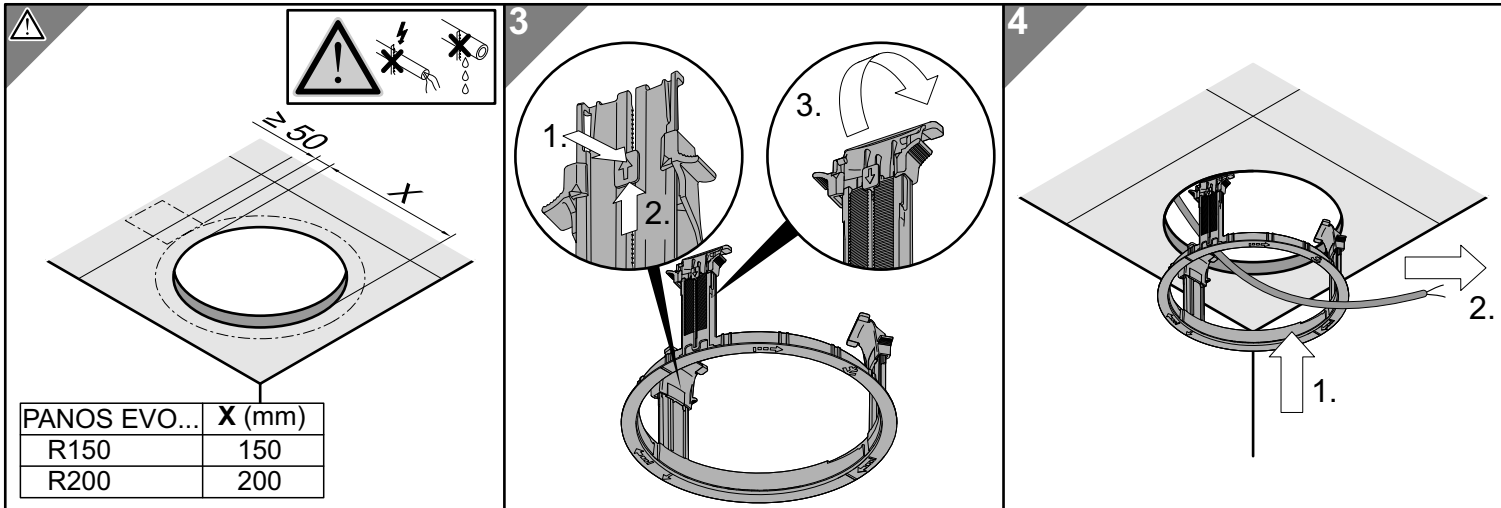

9

DALI/DSI

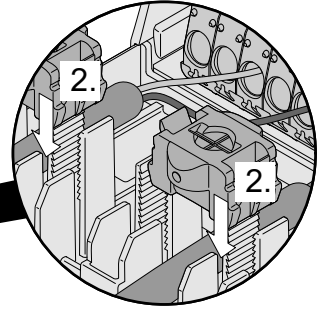
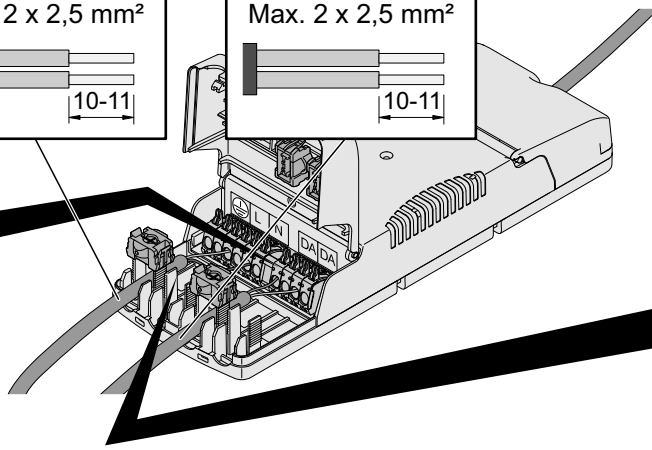
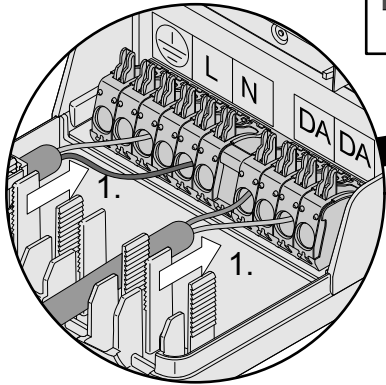
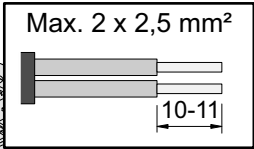
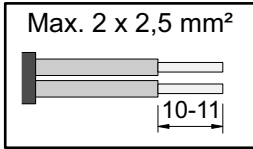

10

Durchschleifen - Looping-in (feed through)
 Câblage traversant (le luminaire)
 Cablaggio passante - Doorlussen
 Överkoppling - Ketjutus - Enlazado

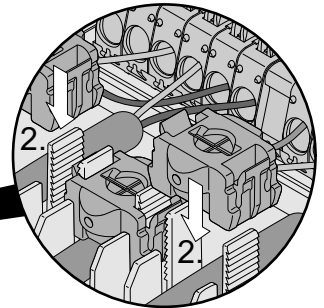
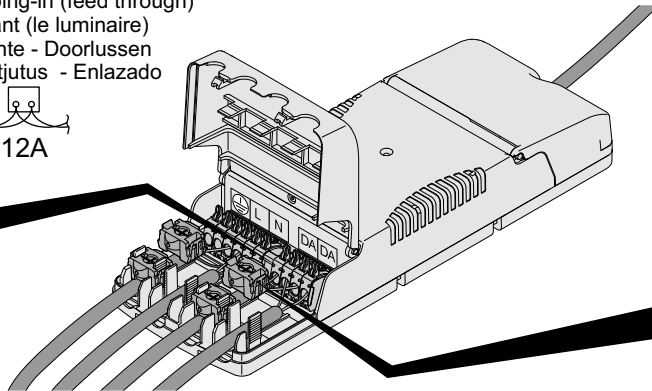
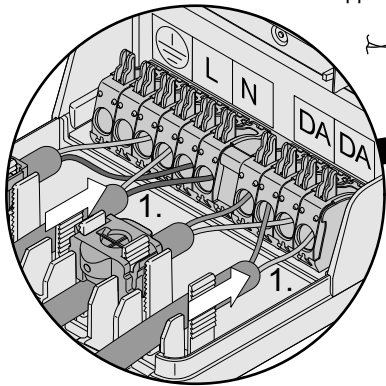
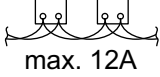

i

switchDIM

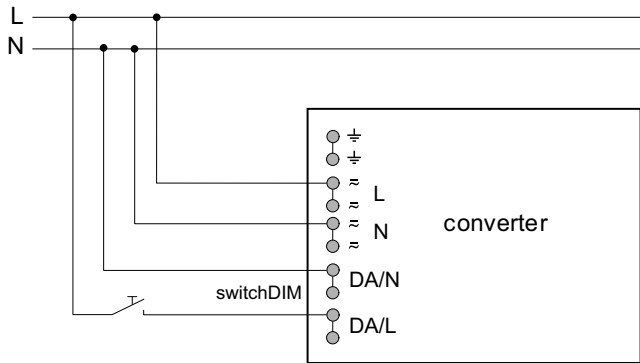

11

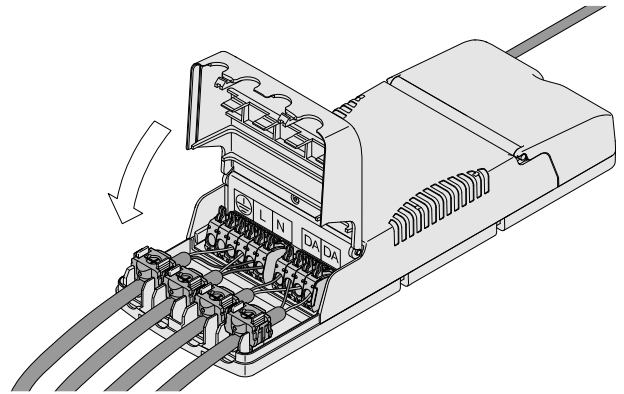

12

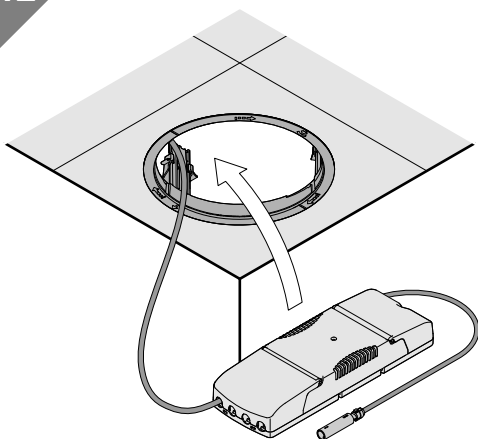

13

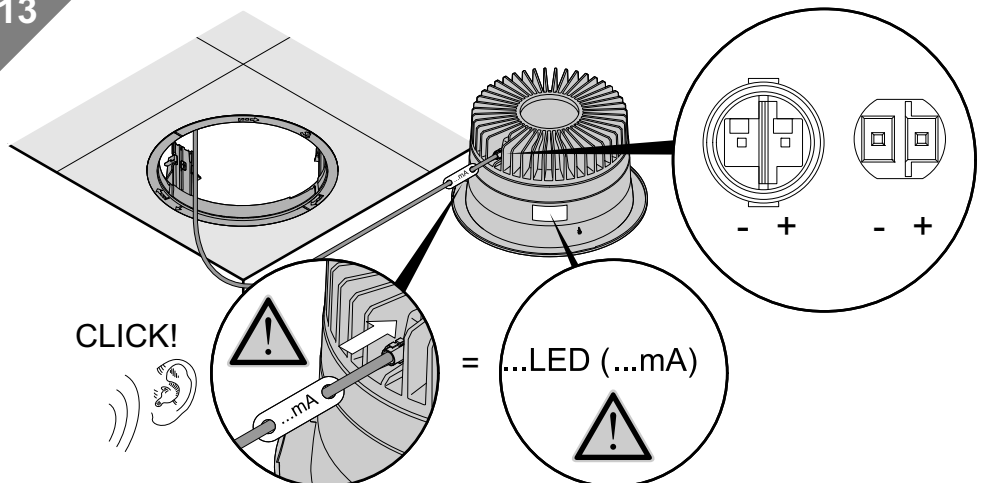

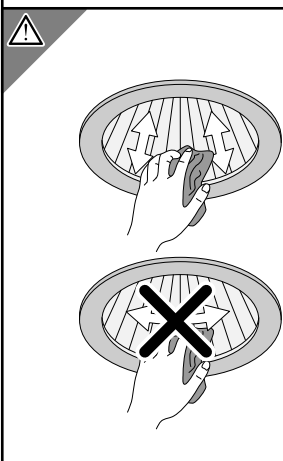
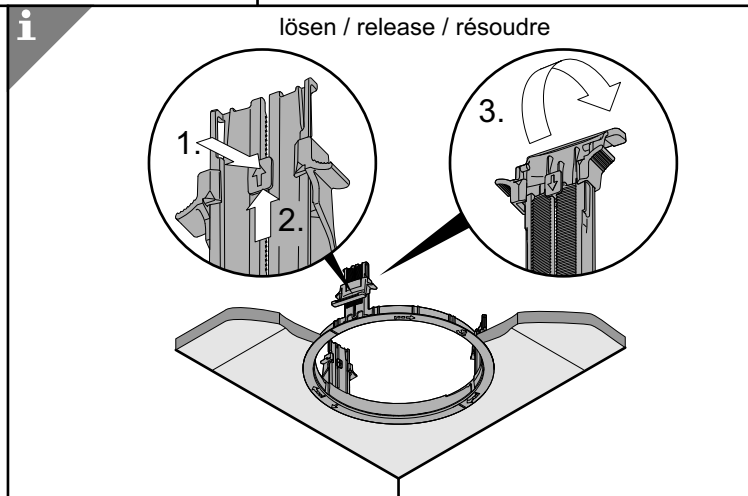
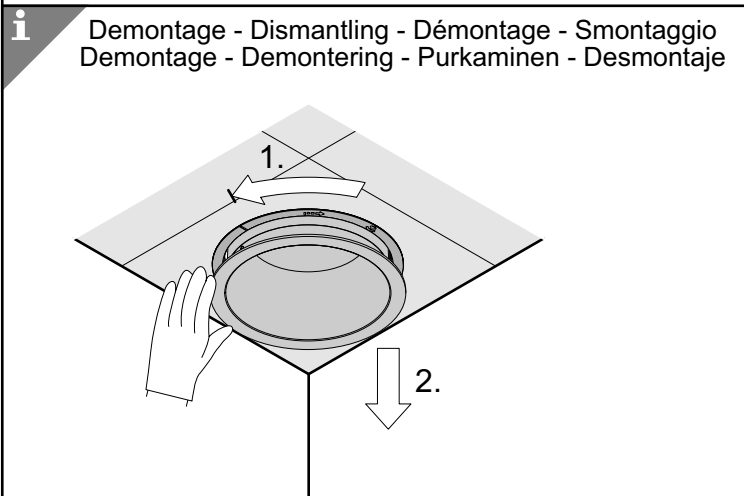
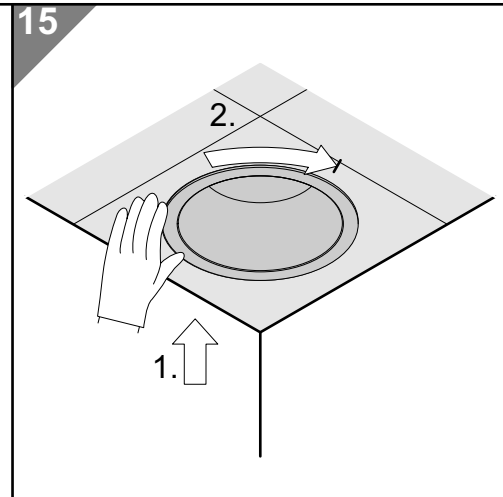
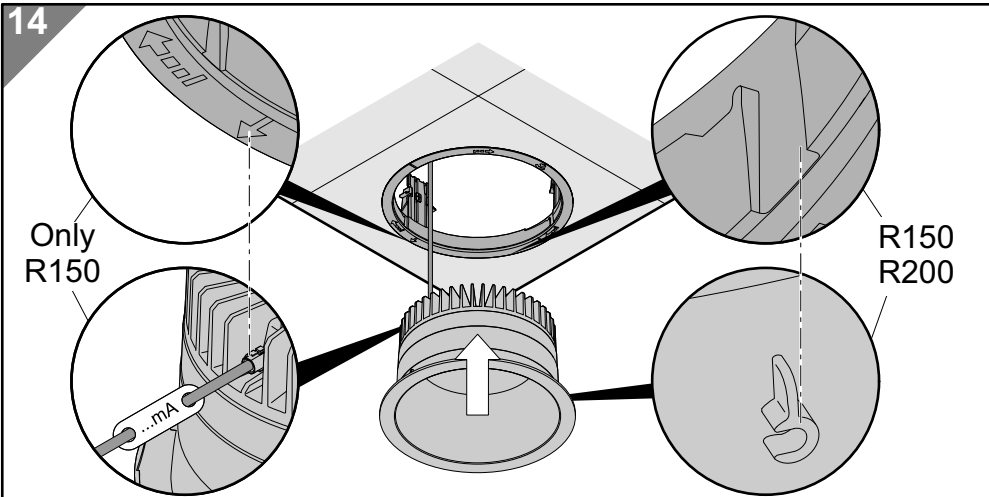

- DE** Reflektorreinigung
- GB** Reflector cleaning
- FR** Nettoyage du réflecteur
- IT** Pulizia di riflettori
- NL** Reflektorreiniging
- NO/SE** Reflektorrengöring
- FI** Reflektorin puhdistus
- ES** Limpieza del reflector

i 60 800 118



- DE** Reflektorreinigungstuch
- GB** Reflector cleaning cloth
- FR** Chiffon de nettoyage du réflecteur
- IT** Straccio per la pulizia di riflettori
- NL** Reinigingsdoek voor reflector
- NO/SE** Reflektorrengöringsduk
- FI** Reflektorinpuhdistusliina
- ES** Paño para limpiar el reflector

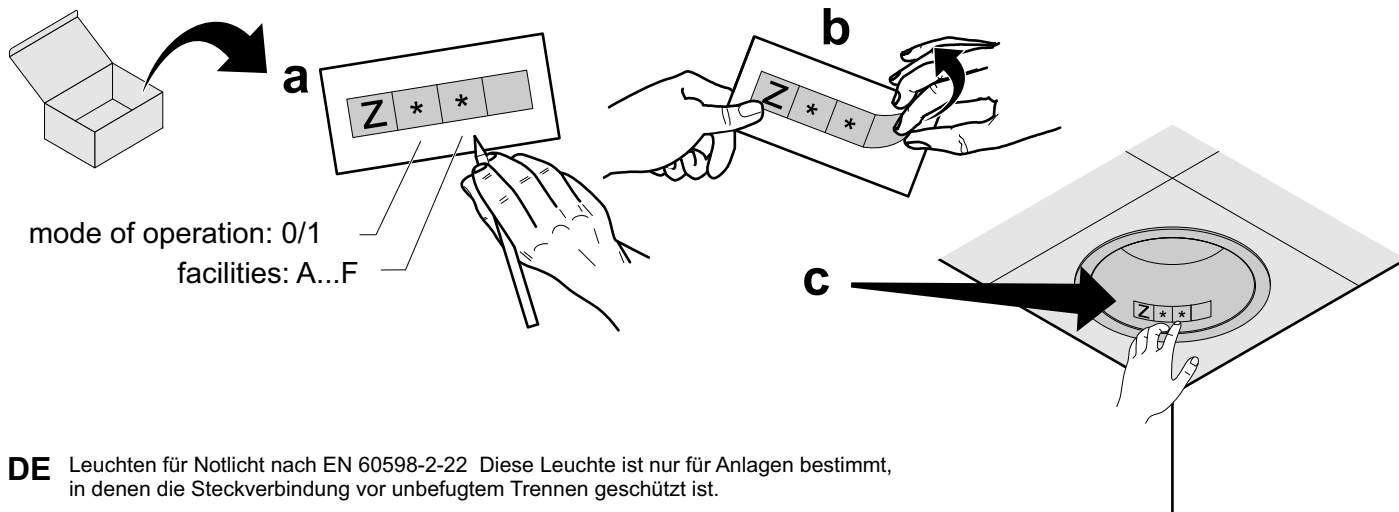

DE Leuchten für Notlicht nach EN 60598-2-22 Diese Leuchte ist nur für Anlagen bestimmt, in denen die Steckverbindung vor unbefugtem Trennen geschützt ist.

GB Option Emergency Lighting EN 60598-2-22 This luminaire is exclusively intended for systems with a plug-in connection that is protected against unauthorized disconnecting.

FR Option Emergency Lighting EN 60598-2-22 Ce luminaire est uniquement destiné aux installations où le connecteur est protégé contre toute déconnexion involontaire.

IT Opzione luce di emergenza EN 60598-2-22 Questo apparecchio è destinato unicamente ad impianti in cui non è possibile staccare l'innesto se non dietro autorizzazione.

NL Optie Emergency Lighting EN 60598-2-22 Deze armatuur is enkel bedoeld voor installaties waarbij de steekverbinding beschermd is tegen onbedoelde ontkoppeling.

NO/SE Option Emergency Lighting EN 60598-2-22 Denna armatur är endast avsedd för anläggningar i vilka stickkontakten inte kan dras ut av obehöriga.

FI Lisävaruste hätävalaisin EN 60598-2-22 Tämä valaisin on tarkoitettu vain sellaisille laitteistoille, joissa pistoliitäntä on suojattu tahattomalta katkaisulta.

ES Opción Emergency Lighting EN 60598-2-22 Esta luminaria está destinada únicamente a sistemas en los que el conector enchufable está protegido contra su separación imprevista.

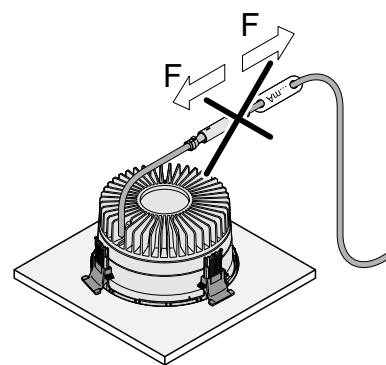

Technische Änderungen vorbehalten. - Specifications subject to change without notice. - Modifications techniques sans préavis.
Modifiche tecniche senza preavviso. - Technische wijzigingen voorbehouden.
Med forbehold om tekniske endringer. - Oikeudet teknisiin muutoksiin pidätetään. - Modificaciones técnicas sin preaviso.