

DISPLAY Elektronik GmbH

DATA SHEET

LCD MODULE

DEM 240064C1 FGH-PW

Product Specification

Version: 2

25.07.2019

GENERAL SPECIFICATION

MODULE NO. :

DEM 240064C1 FGH-PW

CUSTOMER P/N

VERSION NO.	CHANGE DESCRIPTION	DATE
0	Original Version	19.08.2017
1	Correct the Duty/Bias Correct the Storage Temperature	29.08.2017
2	Correct the J1 Description	25.07.2019

PREPARED BY: DM

DATE: 25.07.2019

APPROVED BY: MH

DATE: 25.07.2019

CONTENTS

1. FUNCTIONS & FEATURES2

2. MODULE ARTWORK2

3. EXTERNAL DIMENSIONS.....3

4. BLOCK DIAGRAM.....4

5. PIN ASSIGNMENT5

6. POWER SUPPLY6

7. PCB DRAWING AND DESCRIPTION7

8. BACKLIGHT ELECTRICAL/OPTICAL SPECIFICATION8

9. ABSOLUTE MAXIMUM RATINGS9

10. ELECTRICAL CHARACTERISTICS10

11. COMMAND DEFINITIONS 11

12. THE MODULE ACCEPT QUALITY LEVEL (AQL).....13

13. RELIABILITY TEST13

14. LCD MODULES HANDLING PRECAUTIONS.....14

14. OTHERS.....14

1. FUNCTIONS & FEATURES

MODULE NAME	LCD Type	Backlight Color
DEM 240064C1 FGH-PW	FSTN Transflective Positive Mode	White

- Viewing Direction : 6 O'clock
- Driving Scheme : 1/64 Duty, 1/9 Bias
- Power Supply for Logic : 5.0 Volt (typ.)
- Display Format : 240 x 64 Dots
- V_{LCD} : 12.6 Volt (typ.)

2. MODULE ARTWORK

- Module Size : 180.00 x 65.00 mm
- Dot Size : 0.49 x 0.49 mm
- Dot Gap : 0.04 mm

3. EXTERNAL DIMENSIONS

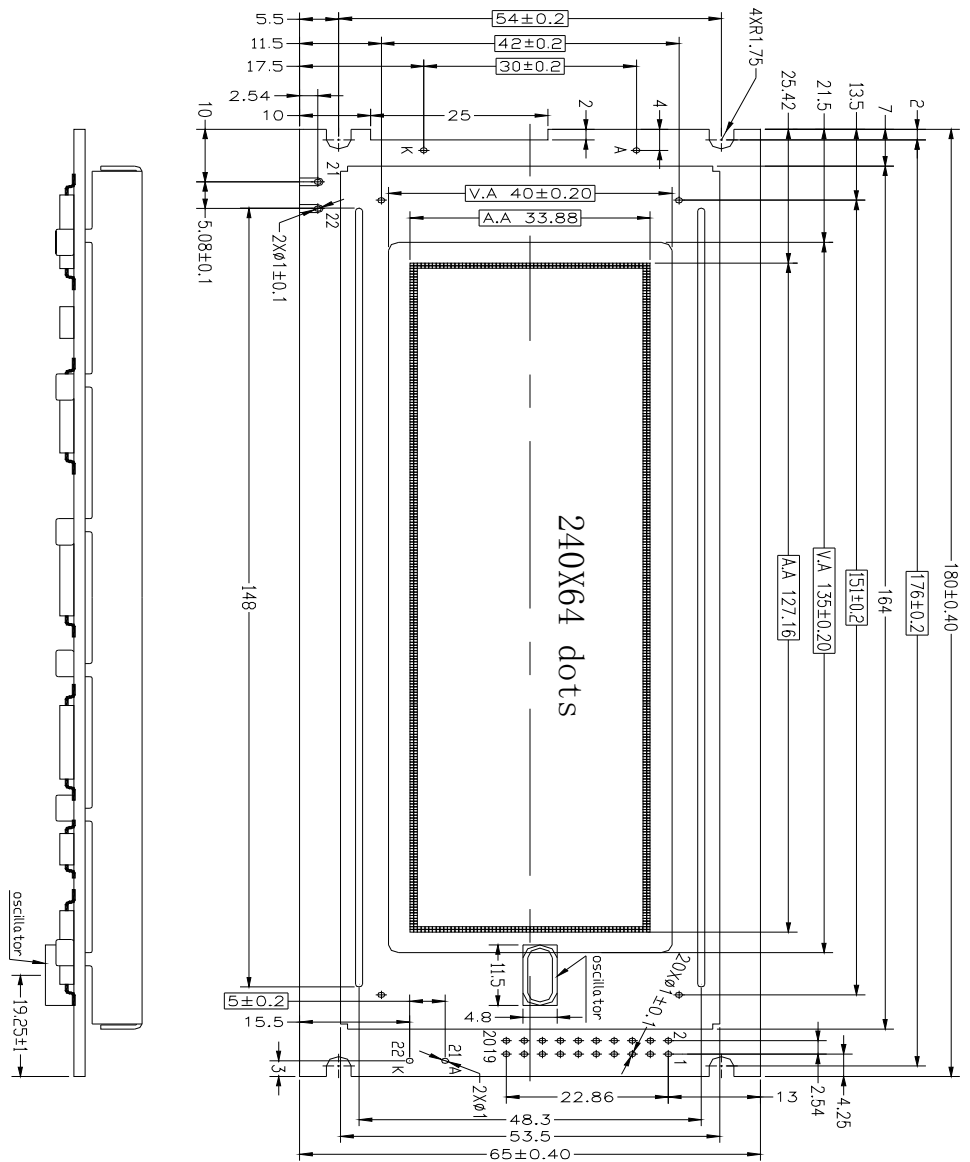

- REMARKS:
- 1. UNMARKED TOLERANCE IS $\pm 0.3\text{mm}$;
 - 2. ALL MATERIAL COMPLY WITH ROHS.

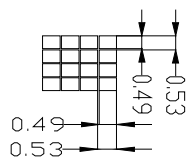
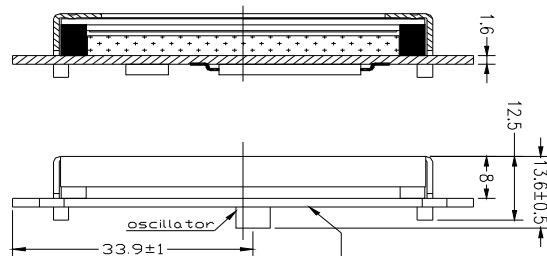

dots detail
scale 5 : 1

P/N: DEM 240064C1 FGH-PW

4. BLOCK DIAGRAM

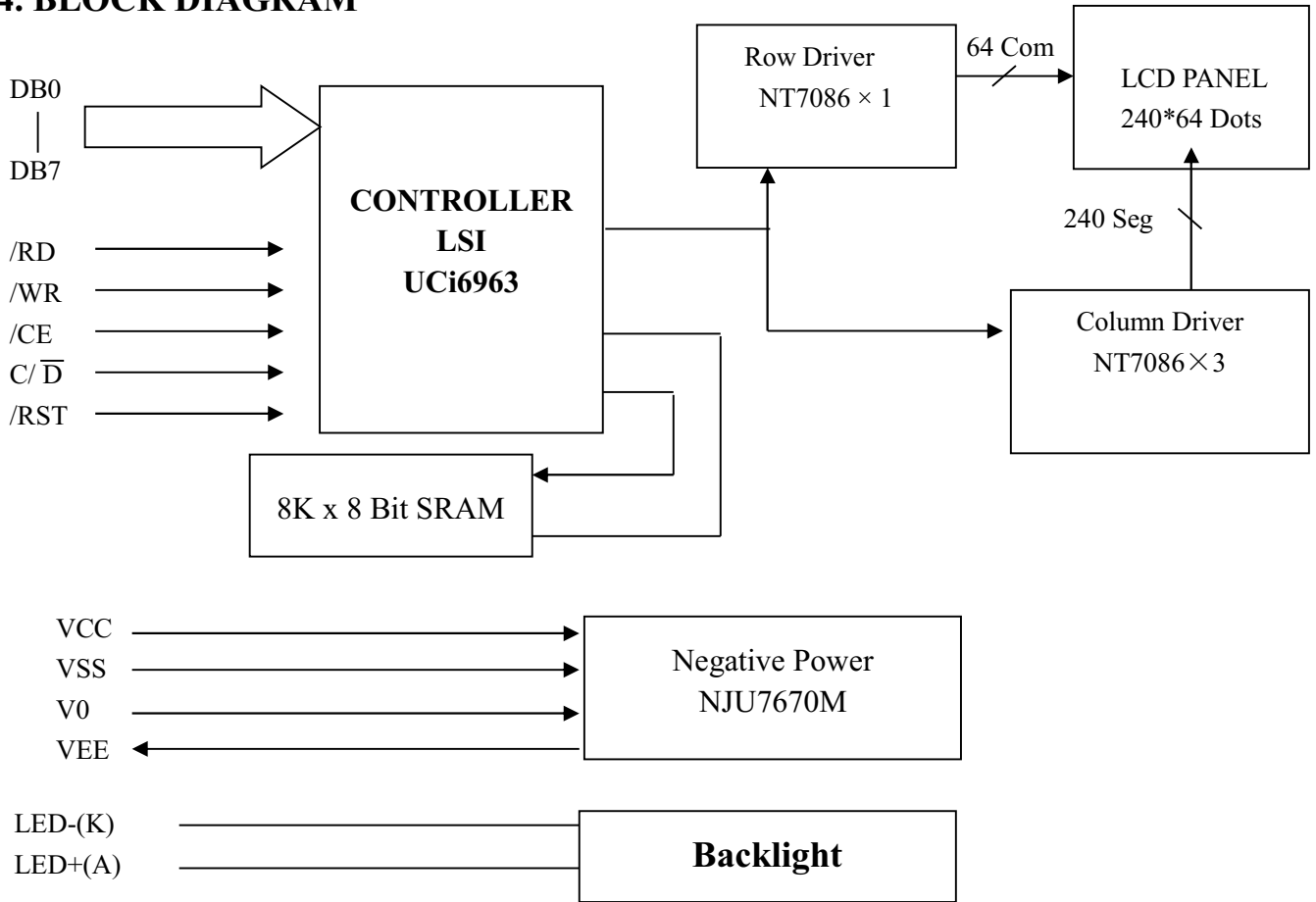

5. PIN ASSIGNMENT

NO.	SYMBOL	FUNCTION
1	FG	Frame ground (see mote 1)
2	VSS	Ground (0V)
3	VDD	Power Supply(+5V)
4	V0	Power Supply for LCD Drive
5	/WR	Data write. Write data to controller UCi6963C when “L”
6	/RD	Data read. Read data from controller UCi6963C when “L”
7	CE	Chip enable of controller when “L”
8	C/D	Command/Data read/write. “H” for command read/write and “L” for data read/write
9	VEE	The negative power supply for LCD
10	/RST	Controller reset when “L”
11	DB0	Data input/output(LSB)
12	DB1	Data input/output
13	DB2	Data input/output
14	DB3	Data input/output
15	DB4	Data input/output
16	DB5	Data input/output
17	DB6	Data input/output
18	DB7	Data input/output(MSB)
19	FS	Font select. “H” for 6x8 font & “L” for 8x8 font
20	N.C	No Connection
21	LED+(A)	Anode of LED backlight
22	LED-(K)	Cathode of LED backlight

Note: This pin is electrically connected to the metal bezel (frame), but is otherwise not connected. User can choose to connect this pin to ground or leave it open.

6. POWER SUPPLY

Mode (Internal Contrast Regulation) - J7 is close.

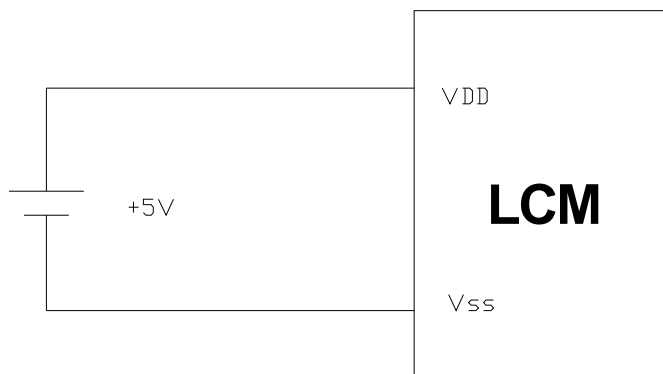

Mode (External Contrast Regulation) - J7 is open.

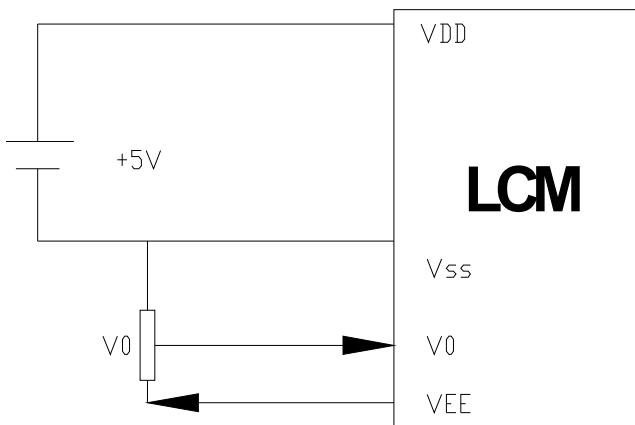

7. PCB DRAWING AND DESCRIPTION

7.1 PCB DRAWING

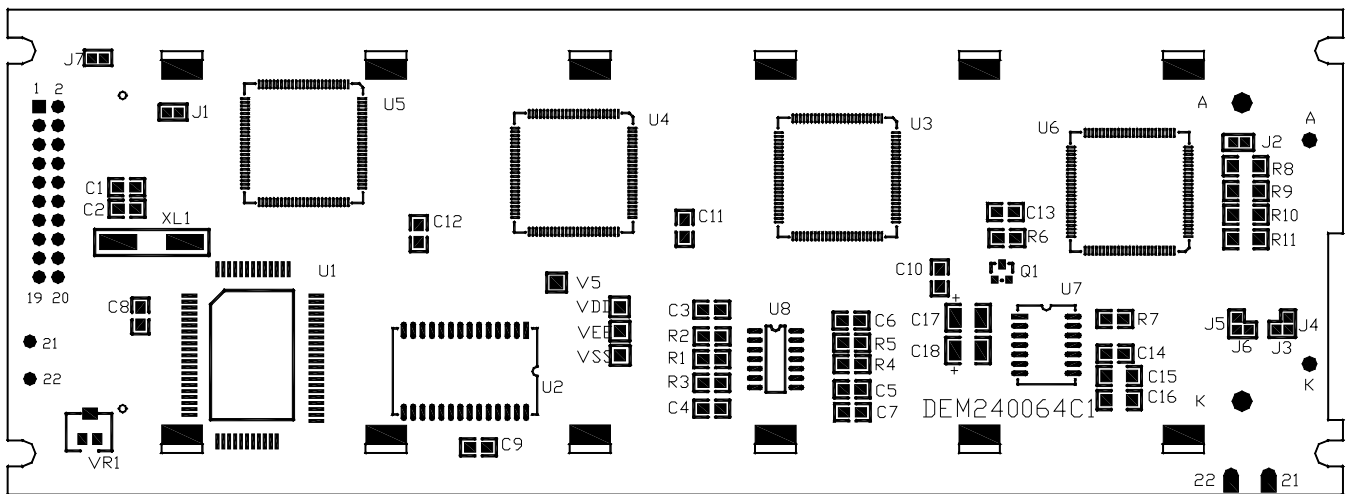

Note: The part no. DEM240064C1 is printed on the PCB.

7.2 DESCRIPTION:

7-2-1. The polarity of the pin 21 and the pin 22:

symbol / state		symbol		LED Polarity	
				J3, J5	J4, J6
J4, J6	Each solder-bridge	Each open	Each closed	Anode	Cathode
J3, J5	Each solder-bridge	Each closed	Each open	Cathode	Anode

Note: In application module, J3=J5= open, J4=J6=0 Ohm

7-2-2. The metal-bezel is set on ground when the J1 is closed.

Note: In application module, J1=0 Ohm

7-2-3. The LED resistor can be bridged when the J2 is closed

Note: In application for module, J2=open

7-2-4. The R8, R9, R10 and the R11 are the LED resistor.

Note: In application module, R8=8.2Ohm, R9=R10= R11=open

7-2-5. The module use internal contrast regulation when J7 is closed.

Note: In application module, J7 is open, but potentiometer is calibrated by the factory.

7-2-6 The VR1 use internal contrast regulation.

Note: In application module, VR1=10k Ohm.

8. BACKLIGHT ELECTRICAL/OPTICAL SPECIFICATION

Item	Symbol	MIN.	TYP.	MAX.	Unit	Condition
Forward Voltage	Vf	3.9	4.1	4.3	V	If = 60X2 mA
Colour Coordinate (Tolerances is ±0.01)	x	0.296	0.287	0.330	0.330	
	y	0.276	0.295	0.339	0.318	
Uniformity	Avg	60			%	
Luminance	Lv	300	400		cd/m ²	
Reverse Current (Per LED)	Ir			30	µA	Vr = 0.8 V

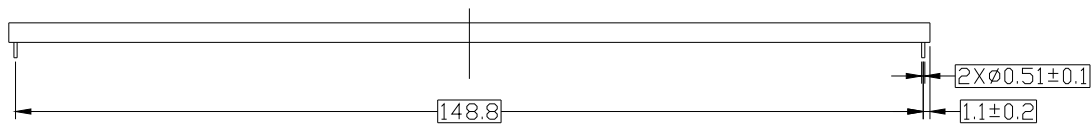
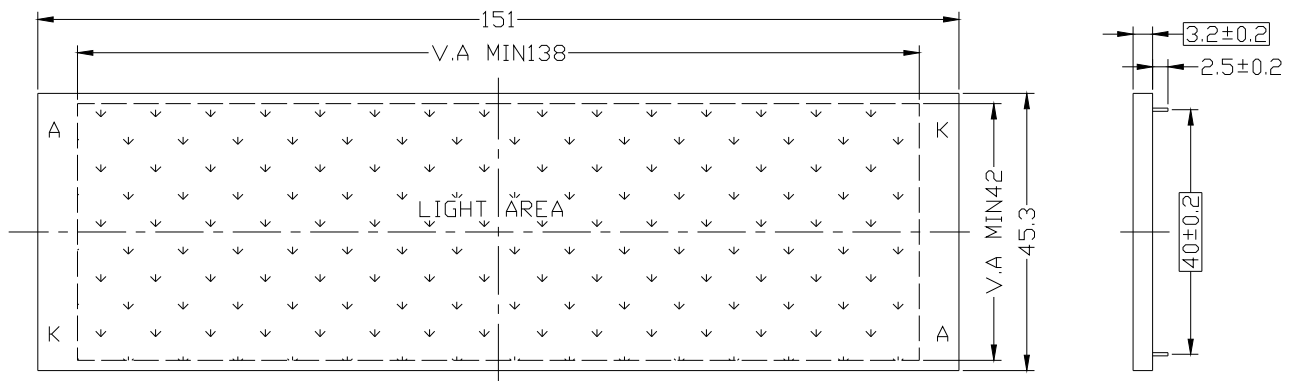

Remarks:
 1.Color:white;
 2.Unmarked tolerance is ±0.3;
 3.All material comply with RoHS.

Circuit Diagram (LED 2X(1X4)=8 Dies)

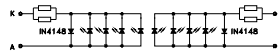

9. ABSOLUTE MAXIMUM RATINGS**9.1 ELECTRICAL ABSOLUTE MAXIMUM RATINGS**(V_{SS}=0V, T_a=25°C)

PARAMETER	SYMBOL	RATING	UNIT
Supply Voltage (Logic)	V _{DD}	-0.3 to 7.0	V
Input Voltage	V _{IN}	-0.3 to V _{DD} +0.3	V
Operating Temperature	T _{opr}	-20 to +70	°C
Storage Temperature	T _{stg}	-30 to +80	°C

9.2 ENVIRONMENTAL ABSOLUTE MAXIMUM RATINGS

Item	Operating		Storage		Comment
	(Min.)	(Max.)	(Min.)	(Max.)	
Ambient Temperature	-20	70	-30	80	Note(1)
Humidity	Note(2)		Note(2)		Without Condensation
Vibration	--	4.9M/S ²	--	19.6M/S ²	XYZ Direction
Shock	--	29.4M/S ²	--	490M/S ²	XYZ Direction

Note (1) T_a=0°C: 50Hr Max.Note (2) T_a≤40°C: 90% RH Max. T_a≥40°C: Absolute humidity must be lower than the humidity of 90% RH at 40°C.

10. ELECTRICAL CHARACTERISTICS

10.1 DC Characteristics

Parameter	Symbol	Conditions	Min.	Typ.	Max.	Units
Supply Voltage (Logic)	V_{DD}	-	4.7	5.0	5.3	V
High Level Input Voltage	V_{IH}	-	$0.8V_{DD}$	-	V_{DD}	V
Low Level Input Voltage	V_{IL}	-	0	-	$0.2 V_{DD}$	V
High Level Output Voltage	V_{OH}		$V_{DD}-0.3$	-	V_{DD}	V
Low Level Output Voltage	V_{OL}		0	-	0.3	V
CurrentConsumption(Operating)	$I_{DD(1)}$	$V_{DD}=5.0V$ $f_{OSC} = 4.0 MHz$	-	TBD		mA

10.2 AC Characteristics

(GND=0V, VDD=5V)

Parameter	Symbol	Min.	Max.	Units
C/D Setup Time	t_{CDS}	100	-	ns
C/D Hold Time	t_{CDH}	10	-	ns
CE, RD, WR Pulse Width	t_{CE}, t_{RD}, t_{WR}	80	-	ns
Data Setup Time	t_{DS}	80	-	ns
Data Hold Time	t_{DH}	40	-	ns
Access Time	t_{ACC}	-	150	ns
Output Hold Time	t_{OH}	10	50	ns

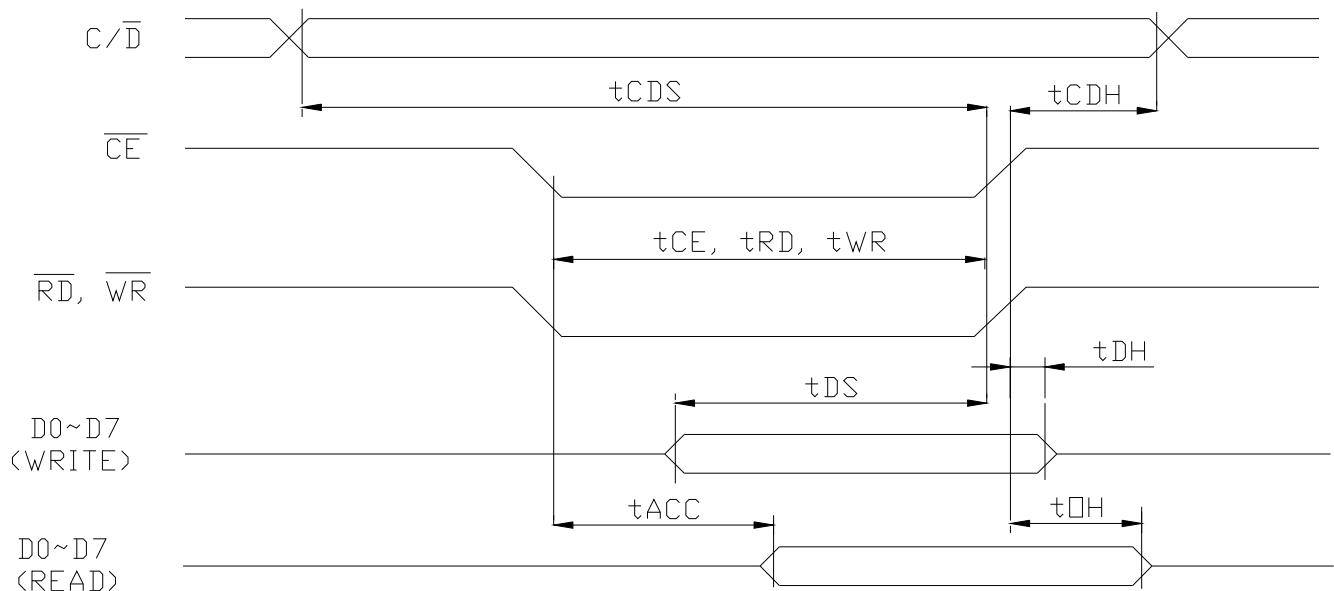

11. COMMAMD DEFINITIONS

No.	Command	C/D	W/R	D7	D6	D5	D4	D3	D2	D1	D0	Action	Value
1.	Set Cursor Pointer	1	0	0	0	1	0	0	0	0	1		21h
		0	0	#	#	#	#	#	#	#	#	Set X address	
		0	0	#	#	#	#	#	#	#	#	Set Y address	
2.	Set Offset Register	1	0	0	0	1	0	0	0	1	0		22h
		0	0	#	#	#	#	#	#	#	#	Data	
		0	0	0	0	0	0	0	0	0	0	0	
3.	Set Address Pointer	1	0	0	0	1	0	0	0	1	0		24h
		0	0	#	#	#	#	#	#	#	#	Low address	
		0	0	#	#	#	#	#	#	#	#	High address	
4.	Set Text Home Addr.	1	0	0	1	0	0	0	0	0	0		40h
		0	0	#	#	#	#	#	#	#	#	Low address	
		0	0	#	#	#	#	#	#	#	#	High address	
5.	Set Text Area	1	0	0	1	0	0	0	0	0	1		41h
		0	0	#	#	#	#	#	#	#	#	Columns	
		0	0	0	0	0	0	0	0	0	0	0	
6.	Set Graphic Home Addr.	1	0	0	1	0	0	0	0	0	1		42h
		0	0	#	#	#	#	#	#	#	#	Low address	
		0	0	#	#	#	#	#	#	#	#	High address	
7.	Set Graphic Area	1	0	0	1	0	0	0	0	1	1		43h
		0	0	#	#	#	#	#	#	#	#	Columns	
		0	0	0	0	0	0	0	0	0	0	0	
8.	OR mode	1	0	1	0	0	0	-	0	0	0		8xh
9.	EXOR mode	1	0	1	0	0	0	-	0	0	1		
10.	AND mode	1	0	1	0	0	0	-	0	1	1		
11.	Text Attribute mode	1	0	1	0	0	0	-	1	0	0		
		0	0	-	-	-	-	#	#	#	#		
12.	Internal CG ROM mode	1	0	1	0	0	0	0	-	-	-		
13.	External CG RAM mode	1	0	1	0	0	0	1	-	-	-		
14.	Display Mode	1	0	1	0	0	1	#	#	#	#	Switch Graphic/Text/Cursor/Blink ON/OFF	9xh
15.	Cursor Pattern Select	1	0	1	0	1	0	0	#	#	#	Set cursor: 1~8-line	Axh
16.	Data-write and Increase ADP	1	0	1	1	0	0	0	0	0	0		C0h
		0	0	#	#	#	#	#	#	#	#	Data	
17.	Data-read and Increase ADP	1	1	1	1	0	0	0	0	0	1		C1h
18.	Data-write and Decrease ADP	1	0	1	1	0	0	0	0	1	0		C2h
		0	0	#	#	#	#	#	#	#	#	Data	
19.	Data-read and Decrease ADP	1	1	1	1	0	0	0	0	1	1		C3h
20.	Data-write and Non-variable ADP	1	0	1	1	0	0	0	1	0	0		C4h
		0	0	#	#	#	#	#	#	#	#	Data	
21.	Data-read and Non-variable ADP	1	1	1	1	0	0	0	1	0	1		C5h
22.	Set Data Auto Write	1	0	1	0	1	1	0	0	0	0		B0h
23.	Set Data Auto Read	1	0	1	0	1	1	0	0	0	1		B1h
24.	Auto Reset	1	0	1	0	1	1	0	0	1	0		B2h
25.	Screen Peek	1	0	1	1	1	0	0	0	0	0		E0h
26.	Screen Copy	1	0	1	1	1	0	1	0	0	0		E8h
27.	Bit Set/Reset	1	0	1	1	1	1	#	#	#	#	Set/Reset Bit 0~7	Fxh
28.	Whole Screen Reverse (Triple-byte command)	1	0	1	1	0	1	0	0	0	0		D0h
		0	0	-	-	-	-	-	-	-	#	0: Normal 1: Reverse	
		0	0	-	-	-	-	-	-	-	-	(Don't Care)	

No.	Command	C/D	W/R	D7	D6	D5	D4	D3	D2	D1	D0	Action	Value
29.	Blink Time (Triple-byte command)	1	0	0	1	0	1	0	0	0	0		50h
		0	0	-	-	-	-	-	#	#	#	000b: 0.066s 100b: 1s 001b: 0.25s 101b: 1.25s 010b: 0.5s 110b: 1.5s 011b: 1.75s 111b: 2s	010b
		0	0	-	-	-	-	-	-	-	-	-	(Don't Care)
30.	Cursor Auto Moving (Triple-byte command)	1	0	0	1	1	0	0	0	0	0		60h
		0	0	-	-	-	-	-	-	-	#	0: disable 1: enable	
		0	0	-	-	-	-	-	-	-	-	-	(Don't Care)
31.	CGROM Font Select (Triple-byte command)	1	0	0	1	1	1	0	0	0	0		70h
		0	0	-	-	-	-	-	-	#	#	00b: Don't care 01b: Don't care 10b: CGROM Font-01 11b: CGROM Font-02	
		0	0	-	-	-	-	-	-	-	-	-	(Don't Care)

12. THE MODULE ACCEPT QUALITY LEVEL (AQL)

12.1 AQL Standard Value: Fatal Defect =0.1, Major Defect=0.65; Minor Defect =2.5.

12.2 Curtailed Inspection Scheme

Type	Batch Qty	inspection Qty	AQL value	pass	Reject
module product	350PCS < 1000PCS	125pcs	0.1	0	1
			0.65	2	3
			2.5	7	8
	200PCS < 350PCS	80pcs	0.1	0	1
			0.65	1	2
			2.5	5	6
	<200PCS	32pcs	0.1	0	1
			0.65	0	1
			2.5	4	5
Module sample	<200PCS	All inspected	/	/	The sample will be reject when the fateful defect>2pcs or main defect>5pcs.
	>200PCS	125pcs			

- Notes:**
- 1). Batch QTY is the production amount that Production department ship to QA department.
 - 2). All of product will be inspected if the batch QTY less than inspected QTY.
 - 3). Each batch fixed to be 500pcs.

13. RELIABILITY TEST

Operating life time: Longer than 50000 hours (at room temperature without direct irradiation of sunlight)

Reliability characteristics shall meet following requirements.

TEMPERATURE TESTS	NORMAL GRADE
High Temperature Storage	+80°C * 96hrs (Without Polarizer)
Low Temperature Storage	-30°C * 4hrs
High Temperature Operation	+70°C * 96hrs
Low Temperature Operation	-20°C *4hrs
High Temperature, High Humidity	+70°C 95%RH 96hrs (Without Polarizer)
Thermal Shock	-20°C * 30 min 10s ↓ 5Cycles +70°C * 30 min
Vibration Test	Frequency * Swing * Time 40Hz * 4mm * 4hrs
Drop Test	Drop height * Times 1.0m * 6 times

14. LCD MODULES HANDLING PRECAUTIONS

- Please remove the protection foil of polarizer before using.
- The display panel is made of glass. Do not subject it to a mechanical shock by dropping it from a high place, etc.
- If the display panel is damaged and the liquid crystal substance inside it leaks out, do not get any in your mouth. If the substance come into contact with your skin or clothes promptly wash it off using soap and water.
- Do not apply excessive force to the display surface or the adjoining areas since this may cause the color tone to vary.
- The polarizer covering the display surface of the LCD module is soft and easily scratched. Handle this polarize carefully.
- To prevent destruction of the elements by static electricity, be careful to maintain an optimum work environment.
 - Be sure to ground the body when handling the LCD module.
 - Tools required for assembly, such as soldering irons, must be properly grounded.
 - To reduce the amount of static electricity generated, do not conduct assembly and other work under dry conditions.
 - The LCD module is coated with a film to protect the display surface. Exercise care when peeling off this protective film since static electricity may be generated.
- Storage precautions
When storing the LCD modules, avoid exposure to direct sunlight or to the light of fluorescent lamps. Keep the modules in bags designed to prevent static electricity charging under low temperature / normal humidity conditions (avoid high temperature / high humidity and low temperatures below 0°C). Whenever possible, the LCD modules should be stored in the same conditions in which they were shipped from our company.

15. OTHERS

- Liquid crystals solidify at low temperature (below the storage temperature range) leading to defective orientation of liquid crystal or the generation of air bubbles (black or white). Air bubbles may also be generated if the module is subjected to a strong shock at a low temperature.
- If the LCD modules have been operating for a long time showing the same display patterns may remain on the screen as ghost images and a slight contrast irregularity may also appear. Abnormal operating status can be resumed to be normal condition by suspending use for some time. It should be noted that this phenomena does not adversely affect performance reliability.
- To minimize the performance degradation of the LCD modules resulting from caused by static electricity, etc. exercise care to avoid holding the following sections when handling the modules:
 - Exposed area of the printed circuit board
 - Terminal electrode sections