

Top View of Assembly

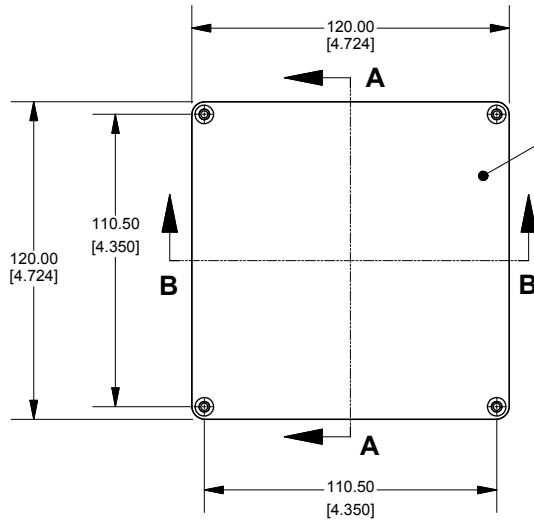

SECTION A-A End View of Assembly

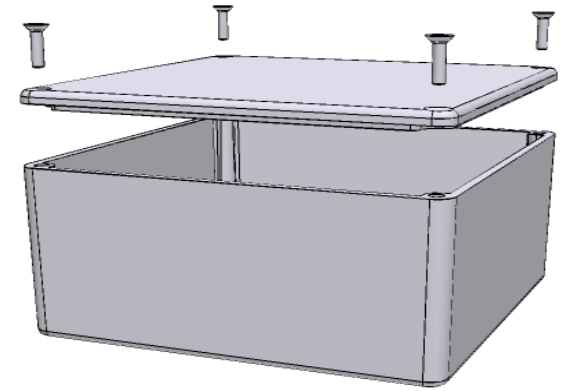
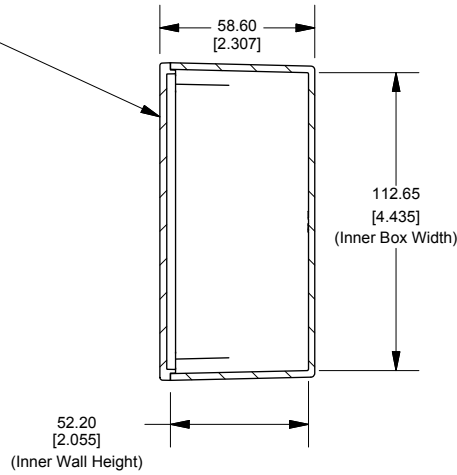

SECTION B-B Side View of Assembly

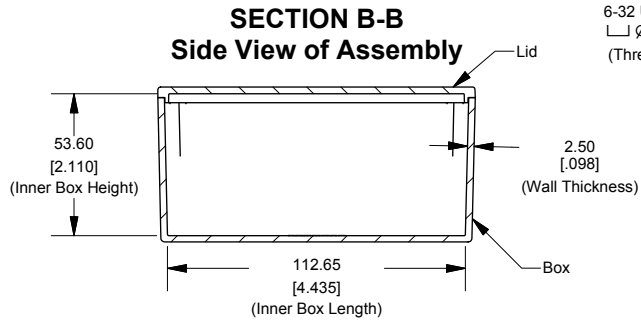

Top View Looking Inside Box

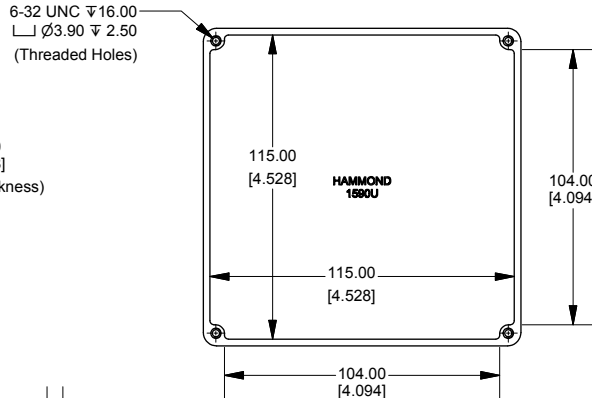

Lid

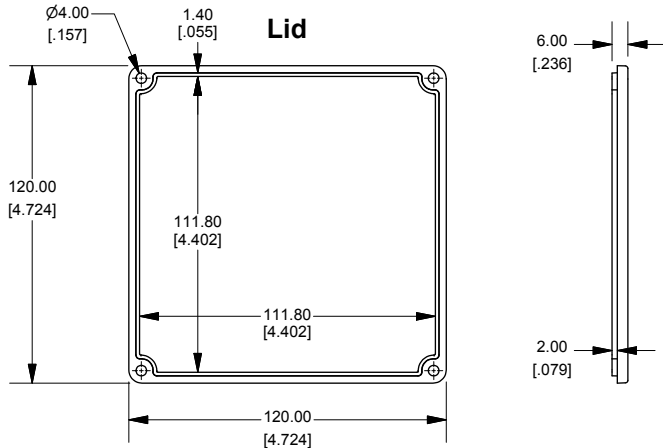

Enclosures can be Factory Modified (Milling, Drilling, Printing etc.)
 Contact Factory mjm@hammondmfg.com for quotes
 Solid models of this enclosure available in STEP or IGES.

NOTE

Purchased assembly includes box, lid and 4 cover screws.
 Box and lid are made from Diecast Aluminum Alloy.
 Silicone Gasket supplied with liquid resistant enclosure.

PART NUMBERS

1590U Enclosure	
Natural Finish Enclosure	1590U
Black Textured Enclosure	1590UBK
1590U Liquid Resistant Enclosure (Silicone Gasket)	
Natural Finish Enclosure	1590WU
Black Textured Enclosure	1590WUBK

ACCESSORIES

Recommended Torque: 75 ozf.in / 55 cN.m

Liquid Resistant Cover Screws

Stainless Steel Cover Screws (Pkg 100) [6-32 x 1/2" With O-Ring]	1590WMS100
Black Stainless Steel Cover Screws (Pkg 100) [6-32 x 1/2" With O-Ring]	1590WMS100BK

Standard Cover Screws

Plated Cover Screws (Pkg 100) [6-32 x 1/2"]	1590MS100
Black Cover Screws (Pkg 100) [6-32 x 1/2"]	1590MS100BK

**HAMMOND
MANUFACTURING™**
1590U
www.hammondmfg.com

Dimensions:
mm
[inches]