

DO NOT SCALE DRAWING

REVISION

A INITIAL DRAWING 21.9.15

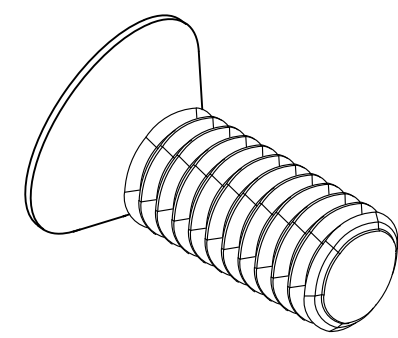
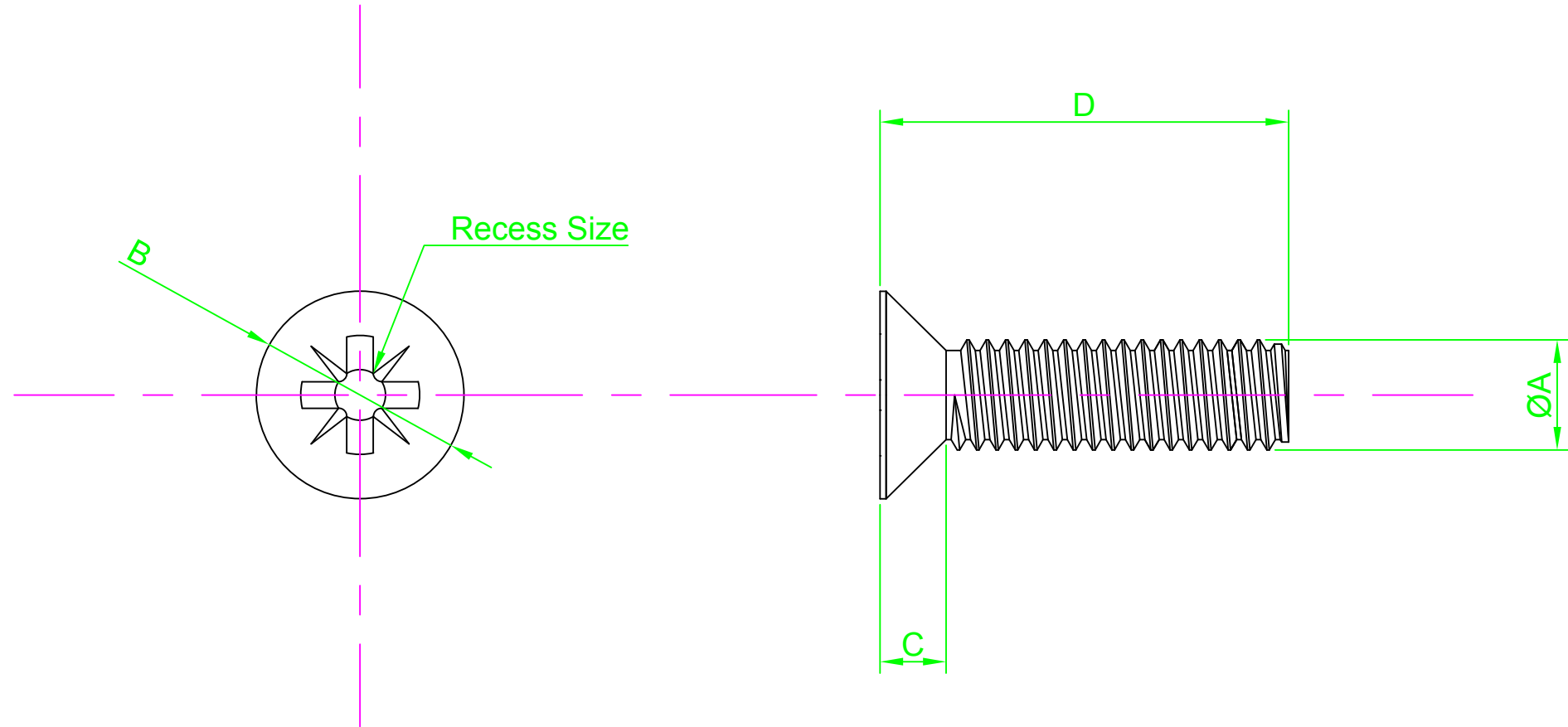

Part Number	ØA	B Nom	C Max	Recess Size	D Length
M3 6 KRSTTT Z100	M3-0.5	5.6	1.65	1	6
M3 8 KRSTTT Z100	M3-0.5	5.6	1.65	1	8
M3 10 KRSTTT Z100	M3-0.5	5.6	1.65	1	10
M4 8 KRSTTT Z100	M4-0.7	7.5	2.2	2	8
M4 10 KRSTTT Z100	M4-0.7	7.5	2.2	2	10
M4 12 KRSTTT Z100	M4-0.7	7.5	2.2	2	12

NOTES:



DESIGN RIGHT. TR FASTENINGS LTD, 2003
 UNDER NO CIRCUMSTANCES MUST THIS
 DRAWING BE COPIED OR DISCLOSED
 WITHOUT FIRST OBTAINING WRITTEN
 AUTHORITY.

UNLESS OTHERWISE SPECIFIED:
 DIMENSIONS ARE IN MM (MILLIMETERS).
 SURFACE FINISH:
 TOLERANCES: DIN 7500

	NAME	DATE
DRAWN	Darryl Wilson	21.09.15
CHK'D		
APPVD		

MATERIAL:
 Steel

HEAT TREATMENT:
 Case Hardened

FINISH:
 TC1D - Commercial Zinc/Clear Trivalent
 De-Embrittle

TITLE:
 Pozi Csk Hd Thread Rolling Screw DIN7500

DRAWING NUMBER:
 TR32KRSTTT

A4

