

DC INDUCTIVE PROXIMITY SENSOR SQUARE TYPE

Q16x28x10	
●	○
1 mm	2 mm
PBT RESIN	
●	



10-30VDC
<10%
<10mA
200mA
<0.01mA
<1.5V
2KHZ
0.1ms/0.1ms
<15%(Sr)
<1.0%(Sr)
IP67
-25 °C - +70 °C
<10%(Sr)
YES
220mA
-

P1S1P2801NOPA3X	25	P1S2P2802NOPA3X
P1S1P2801NCPA3X	25	P1S2P2802NCPA3X
P1S1P2801POPA3X	26	P1S2P2802POPA3X
P1S1P2801PCPA3X	26	P1S2P2802PCPA3X

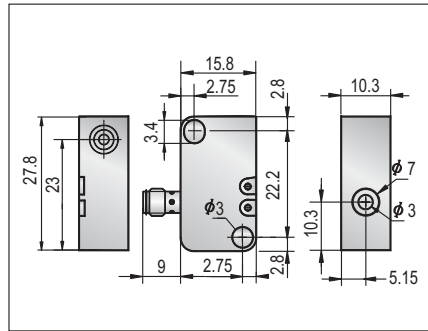

Approx.25 g

Q16x28x10	
●	○
2 mm	4 mm
PBT RESIN	
●	

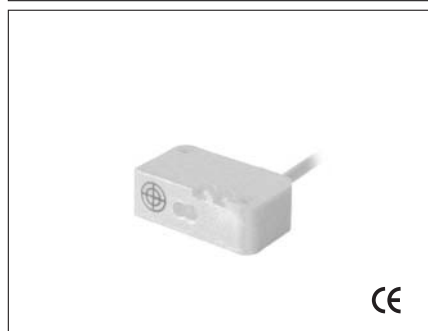

10-30VDC
<10%
<10mA
200mA
<0.01mA
<2.0V
2KHZ
0.1ms/0.1ms
<15%(Sr)
<1.0%(Sr)
IP67
-25 °C - +70 °C
<10%(Sr)
YES
220mA
-

P1S1P2802NO3A2X	1	P1S2P2804NO3A2X
P1S1P2802NC3A2X	2	P1S2P2804NC3A2X
P1S1P2802PO3A2X	3	P1S2P2804PO3A2X
P1S1P2802PC3A2X	4	P1S2P2804PC3A2X

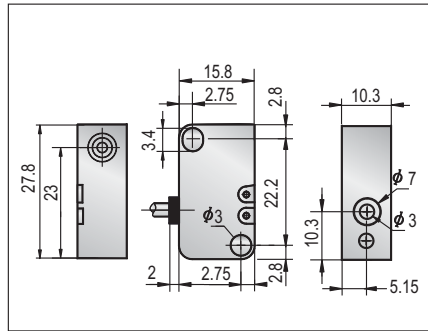

3Ø 3x0.15
Approx.55 g

Q16x28x10	
●	○
2 mm	4 mm
PBT RESIN	
●	



10-30VDC
<10%
<10mA
200mA
<0.01mA
<2.0V
2KHZ
0.1ms/0.1ms
<15%(Sr)
<1.0%(Sr)
IP67
-25 °C - +70 °C
<10%(Sr)
YES
220mA
-

P1S1P2802NOPA3X	25	P1S2P2804NOPA3X
P1S1P2802NCPA3X	25	P1S2P2804NCPA3X
P1S1P2802POPA3X	26	P1S2P2804POPA3X
P1S1P2802PCPA3X	26	P1S2P2804PCPA3X

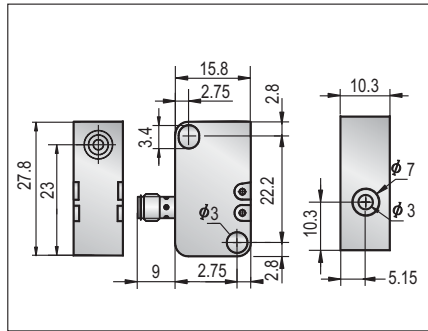

Approx.25 g