

- 1
- 2
- 3
- 4
- 5
- 6
- 7
- 8
- 9
- 10
- 11
- 12
- 13
- 14
- 15
- 16
- 17
- 18

MATERIAL

High-strength, reinforced phenolic based (PF) Duroplast, black colour, glossy finish.

STANDARD EXECUTION

Large diameter black-oxide steel hub, uncovered front end with spot-drilling.
 - **VRU.**: without handle.
 - **VRU+I**: with revolving handle I.301+x (see page 574) in Duroplast.

ACCESSORIES ON REQUEST

Axial retaining washer GN 184 (see page 897).



ELESA Original design

Execution examples for special applications



Square pass-through hole



Drive hole

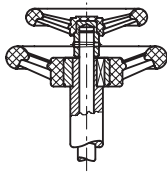

Controlling coaxial shafts

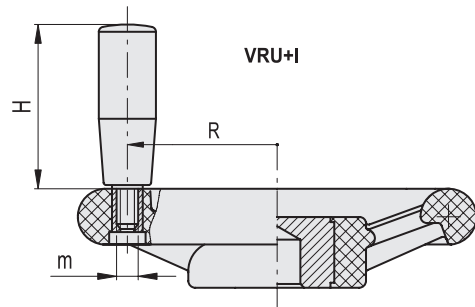
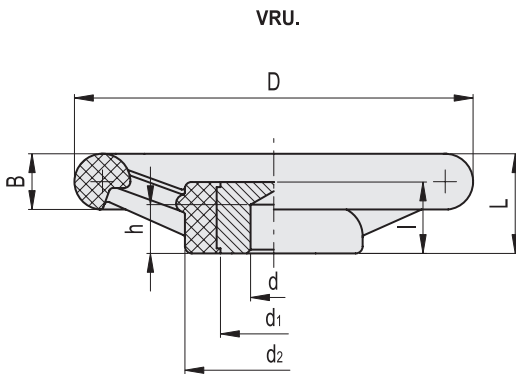

VRU.

Code	Description	D	dH9	L	B	d1	d2	l	h	C# [Nm]	L# [J]	⚖
80001	VRU.125	125	10	28	18	32	55	22	15	220	9	315
80101	VRU.160	160	10	35	22	42	70	26	17	350	13	615
80201	VRU.200	199	12	40	26	53	85	27	20	450	20	990
80301	VRU.250	249	12	49	30	68	105	30	22	650	25	1770

VRU+I

Code	Description	D	dH9	L	B	d1	d2	l	h	H	m	R	C# [Nm]	L# [J]	⚖
80011	VRU.125+I	125	10	28	18	32	55	22	15	65	M8	47	220	9	400
80111	VRU.160+I	160	10	35	22	42	70	26	17	65	M8	60	350	13	700
80211	VRU.200+I	199	12	40	26	53	85	27	20	80	M10	75	450	20	1130
80311	VRU.250+I	249	12	49	30	68	105	30	22	80	M10	99	650	25	1910