



CrossLink-NX VIP Sensor Input Board

Evaluation Board User Guide

FPGA-EB-02029-1.1

September 2020

Disclaimers

Lattice makes no warranty, representation, or guarantee regarding the accuracy of information contained in this document or the suitability of its products for any particular purpose. All information herein is provided AS IS and with all faults, and all risk associated with such information is entirely with Buyer. Buyer shall not rely on any data and performance specifications or parameters provided herein. Products sold by Lattice have been subject to limited testing and it is the Buyer's responsibility to independently determine the suitability of any products and to test and verify the same. No Lattice products should be used in conjunction with mission- or safety-critical or any other application in which the failure of Lattice's product could create a situation where personal injury, death, severe property or environmental damage may occur. The information provided in this document is proprietary to Lattice Semiconductor, and Lattice reserves the right to make any changes to the information in this document or to any products at any time without notice.

Contents

Acronyms in This Document	6
1. Introduction	7
1.1. Further Information	8
2. Headers and Test Connections	9
3. Programming the Board	10
3.1. Programming Circuit	10
3.2. Programming the Device	10
4. CrossLink-NX Interface Support	12
4.1. Camera Sensor Interface	12
4.2. Upstream Connector Interface	12
5. Power Supply	13
6. CrossLink-NX I/O Ball Mapping to Connectors	14
7. Status Indicators	19
8. Input Switches and Pushbuttons	20
9. Ordering Information	20
Appendix A. CrossLink-NX VIP Sensor Input Board Schematics	21
Appendix B. CrossLink-NX VIP Sensor Input Board Bill of Materials	32
References	39
Technical Support Assistance	39
Revision History	40

Figures

Figure 1.1. Top View of CrossLink-NX VIP Sensor Input Board	7
Figure 1.2. Bottom View of CrossLink-NX VIP Sensor Input Board	8
Figure 3.1. Programming Block.....	10
Figure 3.2. Starting Programmer	10
Figure 3.3. Entering File Name.....	11
Figure 3.4. Entering Programming Mode	11
Figure 4.1. Camera Sensor Interface.....	12
Figure 4.2. Upstream Connector Interface	12
Figure 5.1. Power Supply Block.....	13
Figure A.1. Title Page	21
Figure A.2. Block Diagram.....	22
Figure A.3. FTDI/USB Interface	23
Figure A.4. Camera 0-3 Interface	24
Figure A.5. PMOD Interface.....	25
Figure A.6. Downstream Connectors.....	26
Figure A.7. Flash Interface	27
Figure A.8. Power Regulator/Decoupling	28
Figure A.9. Power Distribution/VCCIO	29
Figure A.10. Other Pin Hookup	30
Figure A.11. Power Diagram	31

Tables

Table 2.1. Headers and Test Connectors	9
Table 5.1. Device Power Rail Summary	13
Table 6.1. Upstream Connector Mapping	14
Table 6.2. Camera Sensor Connector Pin Mapping	16
Table 7.1. Status LED I/O Map	19
Table 8.1. Status LED I/O Map	20
Table 9.1. Reference Part Number	20

Acronyms in This Document

A list of acronyms used in this document.

Acronym	Definition
CMOS	Complementary Metal-Oxide Semiconductor
CSI-2	Camera Serial Interface
DDR	Double Data Rate
DSI	Display Serial Interface
FTDI	Future Technology Devices International
GPIO	General Purpose Input/Output
I ² C	Inter-Integrated Circuit
LDO	Low Dropout
LVDS	Low-Voltage Differential Signaling
MIPI	Mobile Industry Processor Interface
MSPI	Master SPI
SMA	SubMiniature version A
SPI	Serial Peripheral Interface
SSPI	Slave SPI
VIP	Video Interface Platform
VTT	Tracking Termination Voltage

1. Introduction

This document describes the Lattice Semiconductor CrossLink-NX™ Video Interface Platform (VIP) Sensor Input Board. The board’s key component is the Lattice CrossLink-NX FPGA, which receives input from the quad on-board Sony IMX258 cameras, and bridges CSI-2 to parallel interfaces.

This board is designed to work with the Lattice VIP board interconnect system. Typically, this board is connected to the ECP5 VIP Processor Board, which can be programmed for a wide range of video processing applications.

The content of this user guide includes descriptions of on-board jumper settings, programming circuit, a complete set of schematics, and bill of materials for CrossLink-NX VIP Sensor Input Board.

Key features of the CrossLink-NX VIP Sensor Input Board include:

- CrossLink-NX FPGA
 - Quad 4-lane MIPI CSI-2 receiver interface
 - SPI flash configuration
 - HyperRAM available for AI applications
 - Up to 24-bit parallel interface
 - General Purpose Input/Output
 - PMOD connectors expansion headers available
- Programming Circuit
 - From programming software via USB/FTDI interface (JTAG or SPI)
 - From on board Flash
 - SPI external programmer using header
- Quad camera interface
 - Quad 4-lane MIPI CSI-2 transmitter interface

Figure 1.1 and Figure 1.2 show the top and bottom views of the CrossLink-NX VIP Sensor Input Board and its key components.

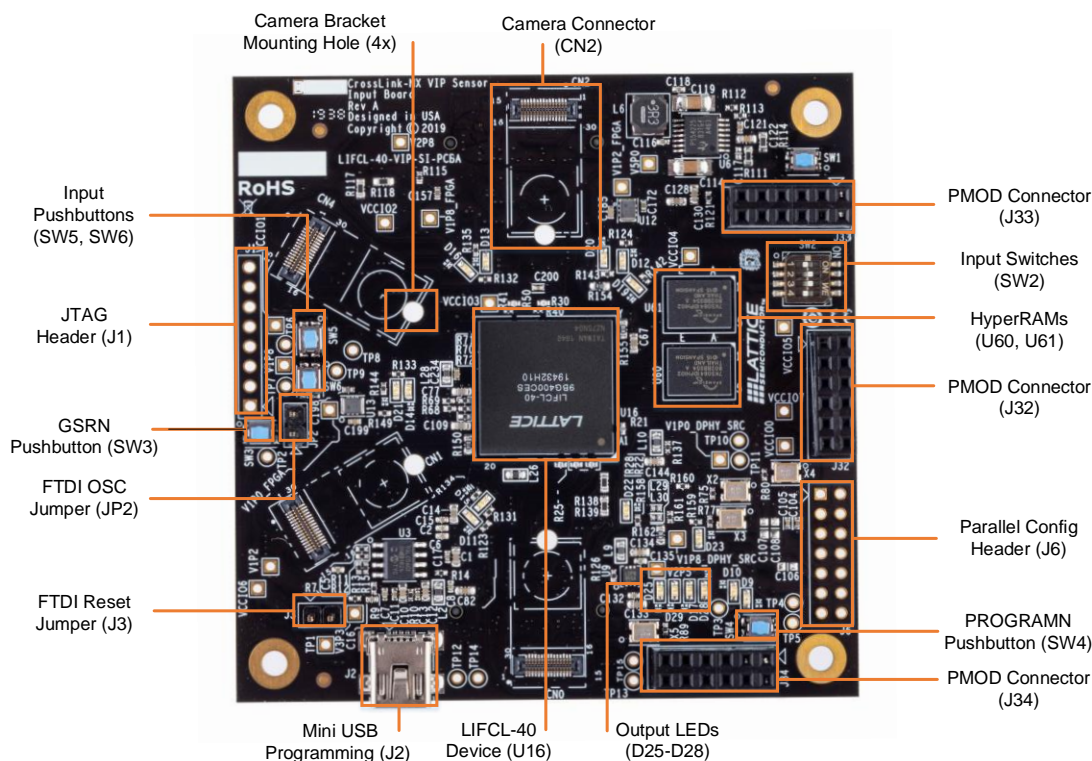

Figure 1.1. Top View of CrossLink-NX VIP Sensor Input Board

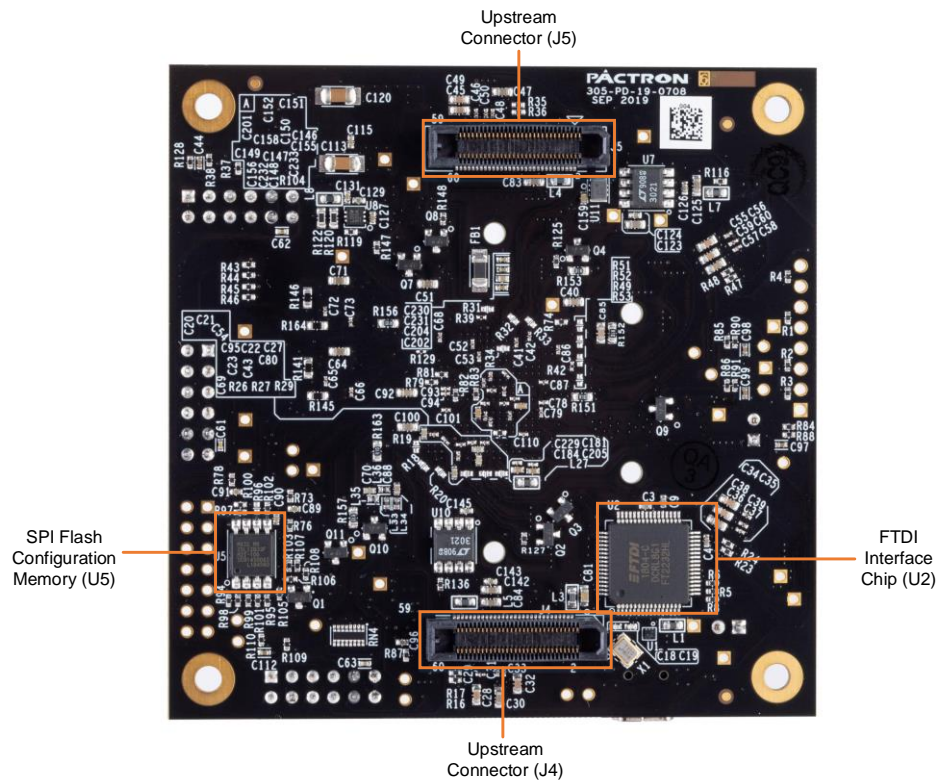

Figure 1.2. Bottom View of CrossLink-NX VIP Sensor Input Board

1.1. Further Information

The following references provide detailed information on the CrossLink-NX VIP Sensor Input Board and the CrossLink-NX FPGA device:

- [Appendix A. CrossLink-NX VIP Sensor Input Board Schematics](#)
- [Appendix B. CrossLink-NX VIP Sensor Input Board Bill of Materials](#)
- www.latticesemi.com/boards for more information on boards and kits available for the VIP (Video Interface Platform) system
- [CrossLink-NX Family Data Sheet \(FPGA-DS-02049\)](#) for details on the CrossLink-NX FPGA

2. Headers and Test Connections

Table 2.1 lists the headers and test connectors as shown in Figure 1.1.

Table 2.1. Headers and Test Connectors

Part	Description	Settings
JP2	FTDI oscillator jumper	Short (osc connected)/Open (osc unconnected)
J3	FTDI Reset Jumper	Short (reset FTDI)/Open (active FTDI)
J1	JTAG Header	—
J6	Parallel Config Header	—
J32, J33, J34	PMOD Header	—

3. Programming the Board

3.1. Programming Circuit

CrossLink-NX can be programmed via USB through the FTDI/JTAG interface using Lattice Radiant® programmer software, or by an external programmer connected to Header J6.

Figure 3.1 shows the programming block of CrossLink-NX VIP Sensor Input board.

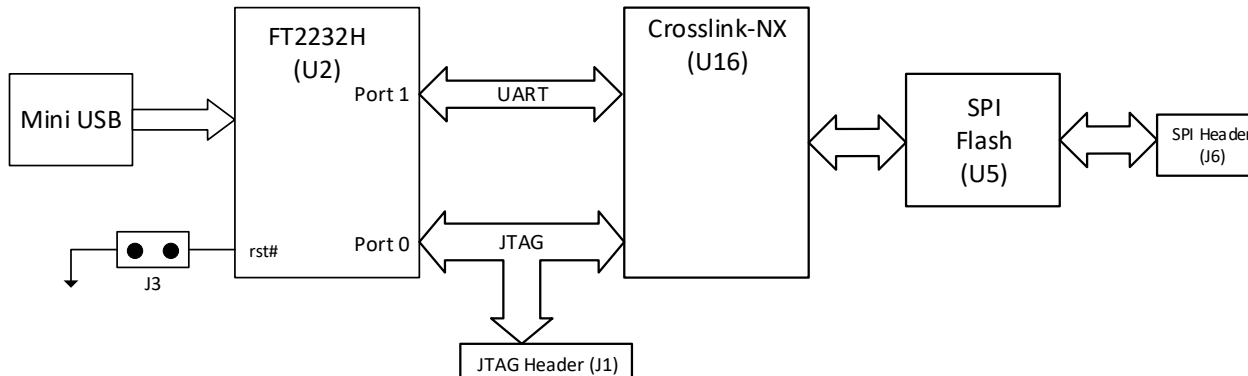

Figure 3.1. Programming Block

The FTDI/JTAG interface is used to program both CrossLink-NX and SPI Flash Memory (Macronix 25L12833 128Mb).

3.2. Programming the Device

This section describes the procedure for programming a pattern to the SRAM (volatile) configuration memory of the Crosslink-NX device. The Crosslink-NX can be programmed through JTAG, I2C, or SPI interfaces. This section focuses on JTAG programming through the USB/FTDI interface. For details on the other configuration modes, refer to the [CrossLink-NX sysConfig Usage Guide \(FPGA-UG-02099\)](#).

The board is programmed through Lattice Radiant programmer software, which can be started as a standalone tool or from a Lattice Radiant project.

To program the CrossLink-NX device:

1. Power on the board by placing it on the EVDK board stack and start a programming project by launching the Lattice Radiant tool and initiating a board scan, as shown in Figure 3.2.

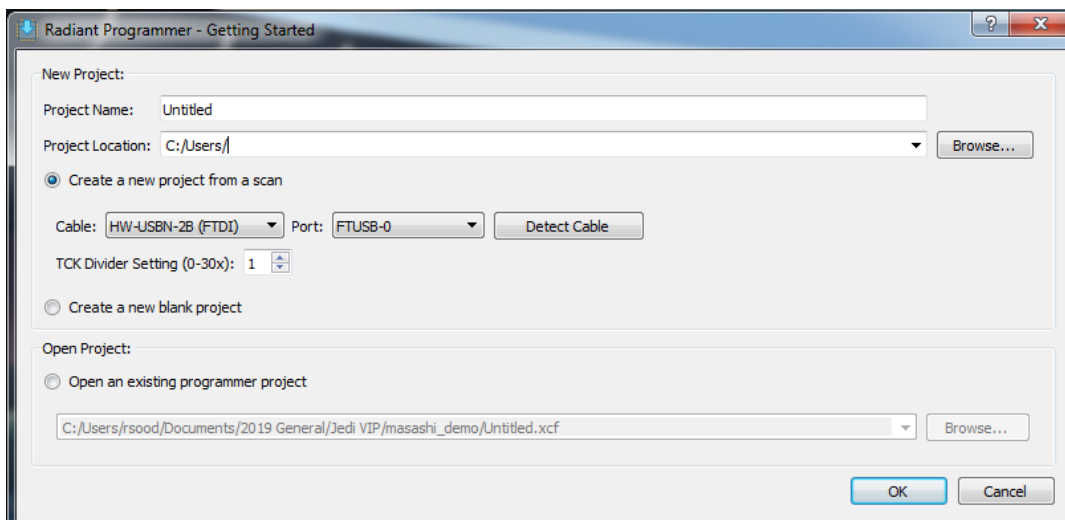

Figure 3.2. Starting Programmer

- After the board is successfully scanned, the main interface opens as shown in [Figure 3.3](#). Enter the file name.

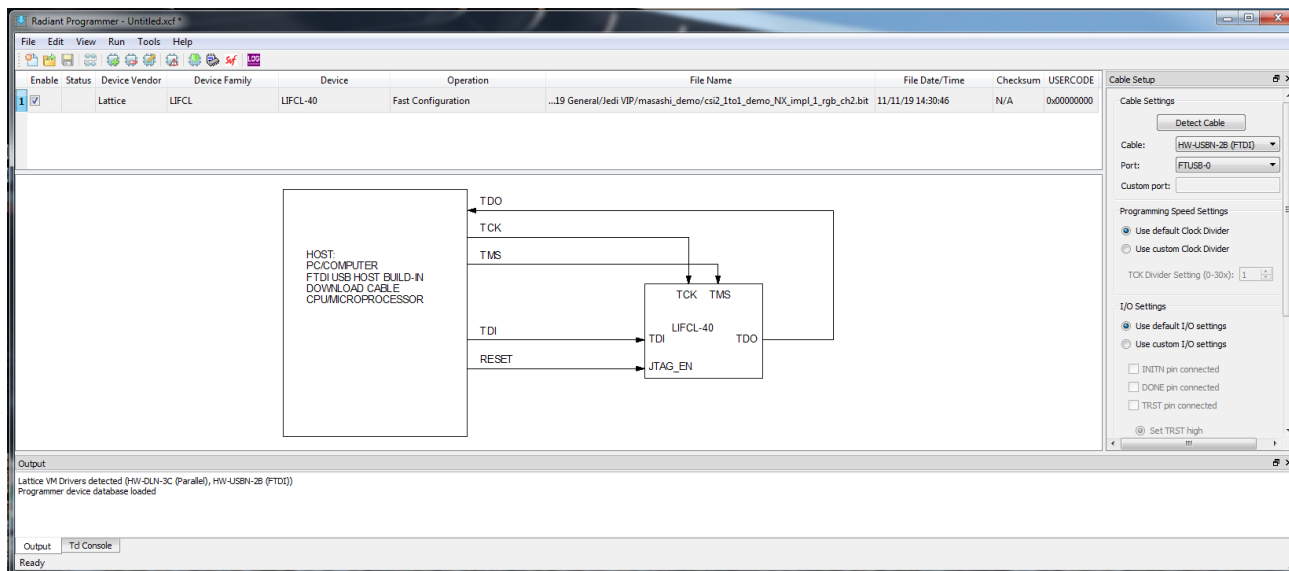

Figure 3.3. Entering File Name

- Double click on the **Operation** field to open the **Device Properties** dialog box and select the appropriate programming mode. In this example, **Fast Configuration** in **Operation** and **JTAG** in **Programming Mode** are selected. Click **OK**.

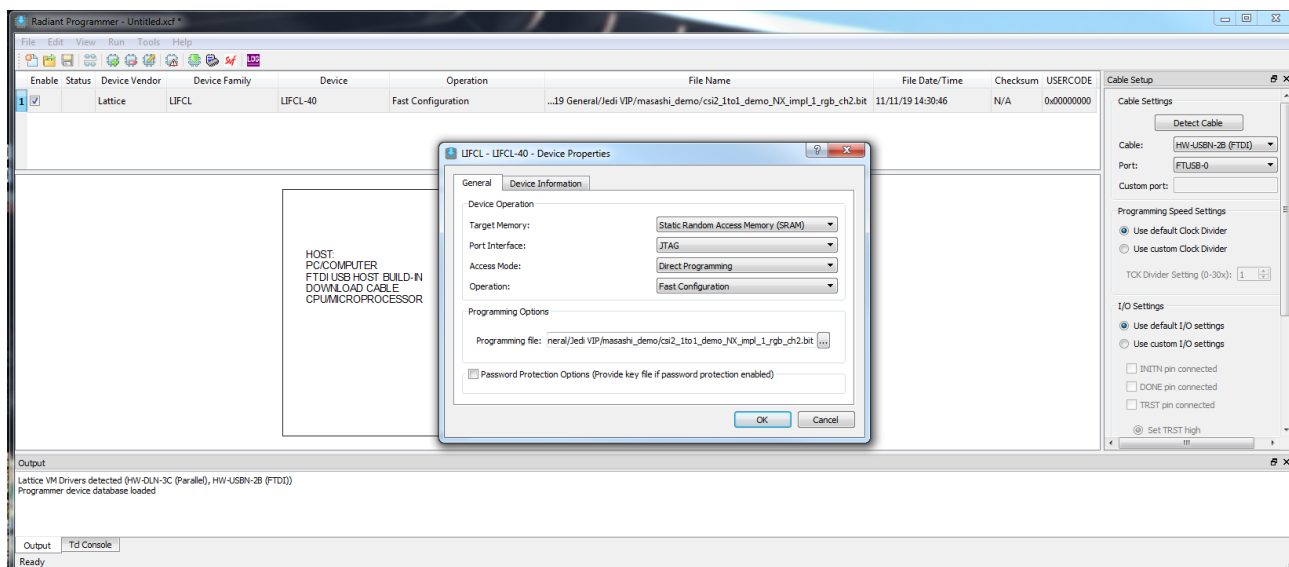

Figure 3.4. Entering Programming Mode

- In the main view, click the **Program** button to configure the Crosslink-NX on the board.

4. CrossLink-NX Interface Support

The CrossLink-NX VIP Sensor Input board supports various onboard interfaces and external interfaces through board-to-board connectors. The sections below describe key onboard interfaces supported on CrossLink-NX VIP Sensor Input board.

4.1. Camera Sensor Interface

Figure 4.1 shows the block diagram of quad camera sensor interface. The Sony IMX258 image sensor is used as input source on the camera sensor connectors. The data path interface between the camera sensor module and CrossLink-NX is CSI-2. The cameras are configured from the CrossLink-NX through the I²C I/O in Bank 6. In addition, frame sync and reset signals drive the cameras from Bank 5.

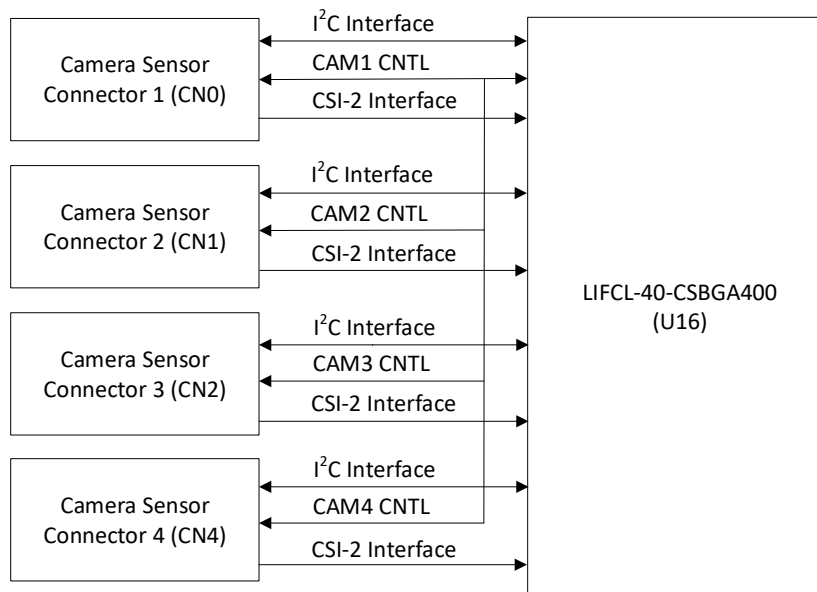

Figure 4.1. Camera Sensor Interface

4.2. Upstream Connector Interface

Figure 4.2 shows the block diagram of the upstream connector. The upstream connector acts as board-to-board connector and interfaces CrossLink-NX VIP Sensor Input Board to the ECP5 VIP processor board for bridging applications. The interface between the Crosslink-NX device and the upstream connector includes a 24-bit parallel data and control interface along with a single I²C channel that can optionally be used to source camera configuration data from the ECP5 device.

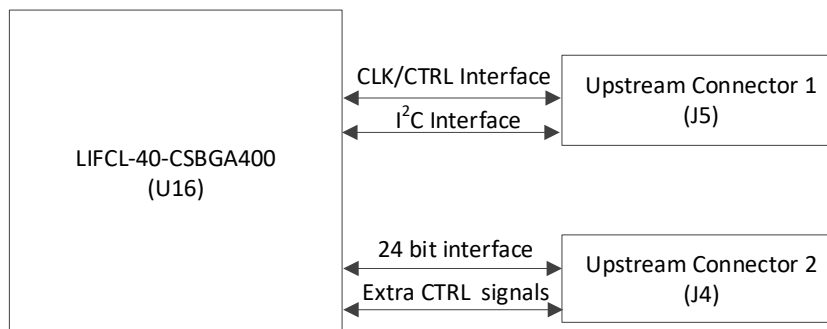

Figure 4.2. Upstream Connector Interface

5. Power Supply

The power supply to CrossLink-NX VIP Sensor Input Board is provided from board-to-board connectors (J1 and J3).

Figure 5.1 shows the power supply block of CrossLink-NX VIP Sensor Input Board. The external board (ECP5 VIP processor board) must be connected to power source for the onboard regulators for normal operation and successful programming. The board-to-board connector provides 5 V, 3.3 V, 2.5 V power source to the board and the onboard regulators to generate remaining power rails. Each I/O and core voltage rail on the board is accessible by a test point on the board.

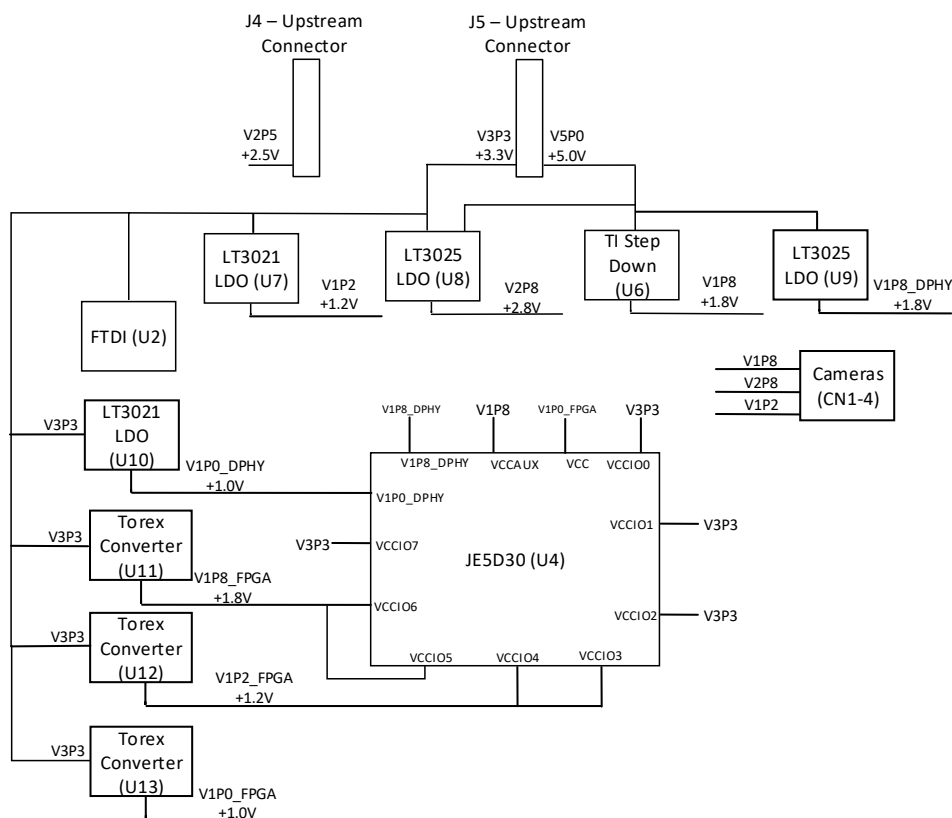

Figure 5.1. Power Supply Block

Table 5.1 lists the board voltage rails, including the rail source voltage, test point number, and voltage on net.

Table 5.1. Device Power Rail Summary

Voltage Rail	Source Rail	Voltage on Net (V)	Status LED	LED Color
V5P0	5P0_EXT	5	D12	Blue
V3P3	3V3_EXT	3.3	D13	Blue
V2P5	2V5_EXT	2.5	D11	Blue
V2P8	V3P3	2.8	D14	Green
V1P8	V5P0	1.8	D16	Green
V1P2	V3P3	1.2	D15	Green
V1P8_DPHY	V5P0	1.8	D22	Green
V1P0_DPHY	V3P3	1.0	D23	Green
V1P8_FPGA	V3P3	1.8	D20	Green
V1P2_FPGA	V3P3	1.2	D19	Green
V1P0_FPGA	V3P3	1.0	D21	Green

6. CrossLink-NX I/O Ball Mapping to Connectors

Table 6.1. Upstream Connector Mapping

J4			J5		
Pin Number on Connector	Net Name	Ball Number	Pin Number on Connector	Net Name	Ball Number
1	3V3_EXT	—	1	3V3_EXT	—
2	3V3_EXT	—	2	5P0_EXT	—
3	3V3_EXT	—	3	3V3_EXT	—
4	3V3_EXT	—	4	5P0_EXT	—
5	D12	P19	5	GND	—
6	D0	N14	6	5P0_EXT	—
7	D13	P20	7	PCLK_DOWN	Y19
8	D1	M14	8	GND	—
9	D14	P17	9	D24	V18
10	D2	M16	10	—	—
11	D15	P18	11	GND	—
12	D3	M15	12	—	—
13	D16	R17	13	D25	V19
14	D4	N15	14	GND	—
15	D17	R18	15	D26	W19
16	D5	N16	16	—	—
17	GND	—	17	GND	—
18	GND	—	18	—	—
19	GND	—	19	—	—
20	GND	—	20	GND	—
21	D18	U20	21	—	—
22	GND	—	22	2V5_EXT	—
23	D19	T20	23	GND	—
24	D6	M17	24	2V5_EXT	—
25	D20	W20	25	—	—
26	D7	M18	26	GND	—
27	D21	V20	27	—	—
28	D8	M19	28	GSRN	G13
29	D22	T18	29	—	—
30	D9	M20	30	—	—
31	D23	U18	31	—	—
32	D10	N19	32	—	—
33	GND	—	33	—	—
34	D11	N20	34	GND	—
35	GND	—	35	—	—
36	GND	—	36	—	—
37	—	—	37	—	—
38	GND	—	38	—	—
39	—	—	39	—	—
40	GND	—	40	GND	—
41	—	—	41	SDA	E20
42	UP_GPIO39	F18	42	—	—

Table 6.1. Upstream Connector Mapping

J4			J5		
Pin Number on Connector	Net Name	Ball Number	Pin Number on Connector	Net Name	Ball Number
43	—	—	43	SCL	F20
44	UP_GPIO40	G19	44	—	—
45	—	—	45	—	—
46	UP_GPIO41	L15	46	GND	—
47	—	—	47	—	—
48	UP_GPIO42	D17	48	—	—
49	—	—	49	—	—
50	—	—	50	—	—
51	—	—	51	—	—
52	—	—	52	GND	—
53	GND	—	53	—	—
54	GND	—	54	—	—
55	GND	—	55	GND	—
56	GND	—	56	—	—
57	2V5_EXT	—	57	GND	—
58	2V5_EXT	—	58	GND	—
59	2V5_EXT	—	59	GND	—
60	2V5_EXT	—	60	—	—

Table 6.2. Camera Sensor Connector Pin Mapping

CN0			CN1			CN2			CN4		
Pin Num	Net Name	Ball Num	Pin Num	Net Name	Ball Num	Pin Num	Net Name	Ball Num	Pin Num	Net Name	Ball Num
1	—	—	1	—	—	1	—	—	1	—	—
2	CAM0_CLKN	B1	2	CAM1_CLKN	B8	2	CAM2_CLKN	Y11	2	CAM3_CLKN	T14
3	CAM0_CLKP	A2	3	CAM1_CLKP	A8	3	CAM2_CLKP	W11	3	CAM3_CLKP	T13
4	GND	—	4	GND	—	4	GND	—	4	GND	—
5	CAM0_3N	B4	5	CAM1_3N	B10	5	CAM2_3N	P12	5	CAM3_3N	R13
6	CAM0_3P	A4	6	CAM1_3P	A10	6	CAM2_3P	R12	6	CAM3_3P	P13
7	GND	—	7	GND	—	7	GND	—	7	GND	—
8	CAM0_1N	B3	8	CAM1_1N	B9	8	CAM2_1N	V12	8	CAM3_1N	V16
9	CAM0_1P	A3	9	CAM1_1P	A9	9	CAM2_1P	W13	9	CAM3_1P	U15
10	GND	—	10	GND	—	10	GND	—	10	GND	—
11	CAM0_ON	C1	11	CAM1_ON	B7	11	CAM2_ON	U11	11	CAM3_ON	Y16
12	CAM0_OP	B2	12	CAM1_OP	A7	12	CAM2_OP	V11	12	CAM3_OP	Y15
13	GND	—	13	GND	—	13	GND	—	13	GND	—
14	CAM0_2N	D1	14	CAM1_2N	B6	14	CAM2_2N	T12	14	CAM3_2N	U16
15	CAM0_2P	C2	15	CAM1_2P	A6	15	CAM2_2P	U12	15	CAM3_2P	V17
16	GND	—	16	GND	—	16	GND	—	16	GND	—
17	GND	—	17	GND	—	17	GND	—	17	GND	—
18	V2P8	—	18	V2P8	—	18	V2P8	—	18	V2P8	—
19	—	—	19	—	—	19	—	—	19	—	—
20	CAM0_MCLK_CN1	M3	20	CAM1_MCLK_CN2	M4	20	CAM1_MCLK_CN3	M5	20	CAM1_MCLK_CN4	M6
21	CAM_FRAME_SYNC	U1	21	CAM_FRAME_SYNC	U1	21	CAM_FRAME_SYNC	U1	21	CAM_FRAME_SYNC	U1
22	I2C0_SDA	N4	22	I2C1_SDA	N6	22	I2C2_SDA	P1	22	I2C3_SDA	P5
23	I2C0_SCL	N5	23	I2C1_SCL	N7	23	I2C2_SCL	P2	23	I2C3_SCL	P6
24	CAM_RESET	T1	24	CAM_RESET	T1	24	CAM_RESET	T1	24	CAM_RESET	T1
25	V1P2	—	25	V1P2	—	25	V1P2	—	25	V1P2	—
26	V1P8	—	26	V1P8	—	26	V1P8	—	26	V1P8	—
27	GND	—	27	GND	—	27	GND	—	27	GND	—
28	GND	—	28	GND	—	28	GND	—	28	GND	—
29	V2P8	—	29	V2P8	—	29	V2P8	—	29	V2P8	—
30	GND	—	30	GND	—	30	GND	—	30	GND	—

Table 6.3. PMOD Connector Pin Mapping

PMOD0 (J34)			PMOD1 (J32)			PMOD2 (J33)		
Pin Num	Net Name	Ball Num	Pin Num	Net Name	Ball Num	Pin Num	Net Name	Ball Num
1	PMOD0_1	D10	1	PMOD1_1	E10	1	PMOD2_1	J2
2	PMOD0_2	D9	2	PMOD1_2	E9	2	PMOD2_2	J1
3	PMOD0_3	D7	3	PMOD1_3	E7	3	PMOD2_3	K2
4	PMOD0_4	D8	4	PMOD1_4	E8	4	PMOD2_4	K1
5	GND	—	5	GND	—	5	GND	—
6	VCCIO7	—	6	VCCIO7	—	6	VCCIO7	—
7	PMOD0_7	D6	7	PMOD1_7	E4	7	PMOD2_7	K3
8	PMOD0_8	D5	8	PMOD1_8	E3	8	PMOD2_8	K4
9	PMOD0_9	D4	9	PMOD1_9	E2	9	PMOD2_9	E17
10	PMOD0_10	D3	10	PMOD1_10	F1	10	PMOD2_10	F13
11	GND	—	11	GND	—	11	GND	—
12	VCCIO7	—	12	VCCIO7	—	12	VCCIO7	—

Table 6.4. HyperRAM Connector Pin Mapping

J4			J5		
Pin Name/Num	Net Name	Ball Num	Pin Name/Num	Net Name	Ball Num
RFU1/A2	—	—	RFU1/A2	—	—
RFU2/A5	—	—	RFU2/A5	—	—
CS#/A3	HR0_CS	V6	CS#/A3	HR1_CS	P9
RESET#/A4	HR0_RST	U7	RESET#/A4	HR1_RST	P10
CK#/B1	HR0_CKN	T7	CK#/B1	HR1_CKN	Y10
CK/B2	HR0_CK	R7	CK/B2	HR1_CK	W10
VSS/B3	GND	—	VSS/B3	GND	—
VSSQ/C1	GND	—	VSSQ/C1	GND	—
VSSQ/E5	GND	—	VSSQ/E5	GND	—
VCC/B4	VCCIO4	—	VCC/B4	VCCIO4	—
VCCQ/E4	VCCIO4	—	VCCQ/E4	VCCIO4	—
VCCQ/D1	VCCIO4	—	VCCQ/D1	VCCIO4	—
RFU3/B5	—	—	RFU3/B5	—	—
RFU4/C2	—	—	RFU4/C2	—	—
RFU5/C5	—	—	RFU5/C5	—	—
RWDS/C3	HR0_RW	W6	RWDS/C3	HR1_RW	R10
DQ0/D3	HR0_DQ0	Y6	DQ0/D3	HR1_DQ0	W8
DQ1/D2	HR0_DQ1	W7	DQ1/D2	HR1_DQ1	V9
DQ2/C4	HR0_DQ2	V7	DQ2/C4	HR1_DQ2	W9
DQ3/D4	HR0_DQ3	P7	DQ3/D4	HR1_DQ3	Y9
DQ4/D5	HR0_DQ4	P8	DQ4/D5	HR1_DQ4	T10
DQ5/E3	HR0_DQ5	R8	DQ5/E3	HR1_DQ5	T11
DQ6/E2	HR0_DQ6	T8	DQ6/E2	HR1_DQ6	U10
DQ7/E1	HR0_DQ7	Y7	DQ7/E1	HR1_DQ7	V10

7. Status Indicators

The LED status indicators on the board show the application status. [Table 7.1](#) lists the status LED I/O map.

Table 7.1. Status LED I/O Map

Net Name	LED	Connector/Pin	Color
LED0	D25	G14	Green
LED1	D29	G15	Green
LED2	D17	L13	Green
LED3	D28	L14	Green

8. Input Switches and Pushbuttons

Table 7.1 below lists all input switches and pushbuttons. This board has one 4 input slider switch and 5 pushbuttons.

Table 8.1. Status LED I/O Map

Net Name	Component	Connector/Pin
SWITCH0	SW2	R5
SWITCH1	SW2	R6
SWITCH2	SW2	Y5
SWITCH3	SW2	W5
CAM_RESET	SW1	T1
PUSHBUTTON0	SW5	L20
PUSHBUTTON1	SW6	L19
GSRN	SW3	G13
PROGRAMN	SW4	E11

9. Ordering Information

This board is included as part of a kit, and not available as a separate item. The below part number is for reference only, so it is clear which board is described in this document. Please visit www.latticesemi.com/boards for the latest ordering information.

Table 9.1. Reference Part Number

Description	Ordering Part Number
CrossLink-NX VIP Sensor Input Board	LIFCL-VIP-SI-EVN

Appendix A. CrossLink-NX VIP Sensor Input Board Schematics

<h3>Crosslink-NX VIP Sensor Input Board Rev - B</h3>																	
<p>01 - Title Page</p> <p>02 - Block Diagram</p> <p>03 - FTDI/USB Interface</p> <p>04 - Camera 0-3 Interface</p> <p>05 - PMOD Interface</p> <p>06 - Downstream Connectors</p> <p>07 - Flash/HyperRAM Interface</p> <p>08 - Power Regulator/Decoupling</p> <p>09 - Power Distribution/VCCIO</p> <p>10 - Other Pin Hookup</p> <p>11 - Power Diagram</p>																	
																	
<p>Lattice Semiconductor Applications http://www.latticesemi.com/Support</p>																	
<table border="1"> <tr> <td colspan="2">Title</td> <td colspan="2">Title Page</td> </tr> <tr> <td>Size</td> <td>Project</td> <td>Schematic Rev</td> <td>1.0</td> </tr> <tr> <td>B</td> <td>Crosslink-NX VIP Sensor Input Board</td> <td>Board Rev</td> <td>B</td> </tr> <tr> <td>Date</td> <td>June 26, 2019</td> <td>Sheet</td> <td>1 of 11</td> </tr> </table>		Title		Title Page		Size	Project	Schematic Rev	1.0	B	Crosslink-NX VIP Sensor Input Board	Board Rev	B	Date	June 26, 2019	Sheet	1 of 11
Title		Title Page															
Size	Project	Schematic Rev	1.0														
B	Crosslink-NX VIP Sensor Input Board	Board Rev	B														
Date	June 26, 2019	Sheet	1 of 11														

Figure A.1. Title Page

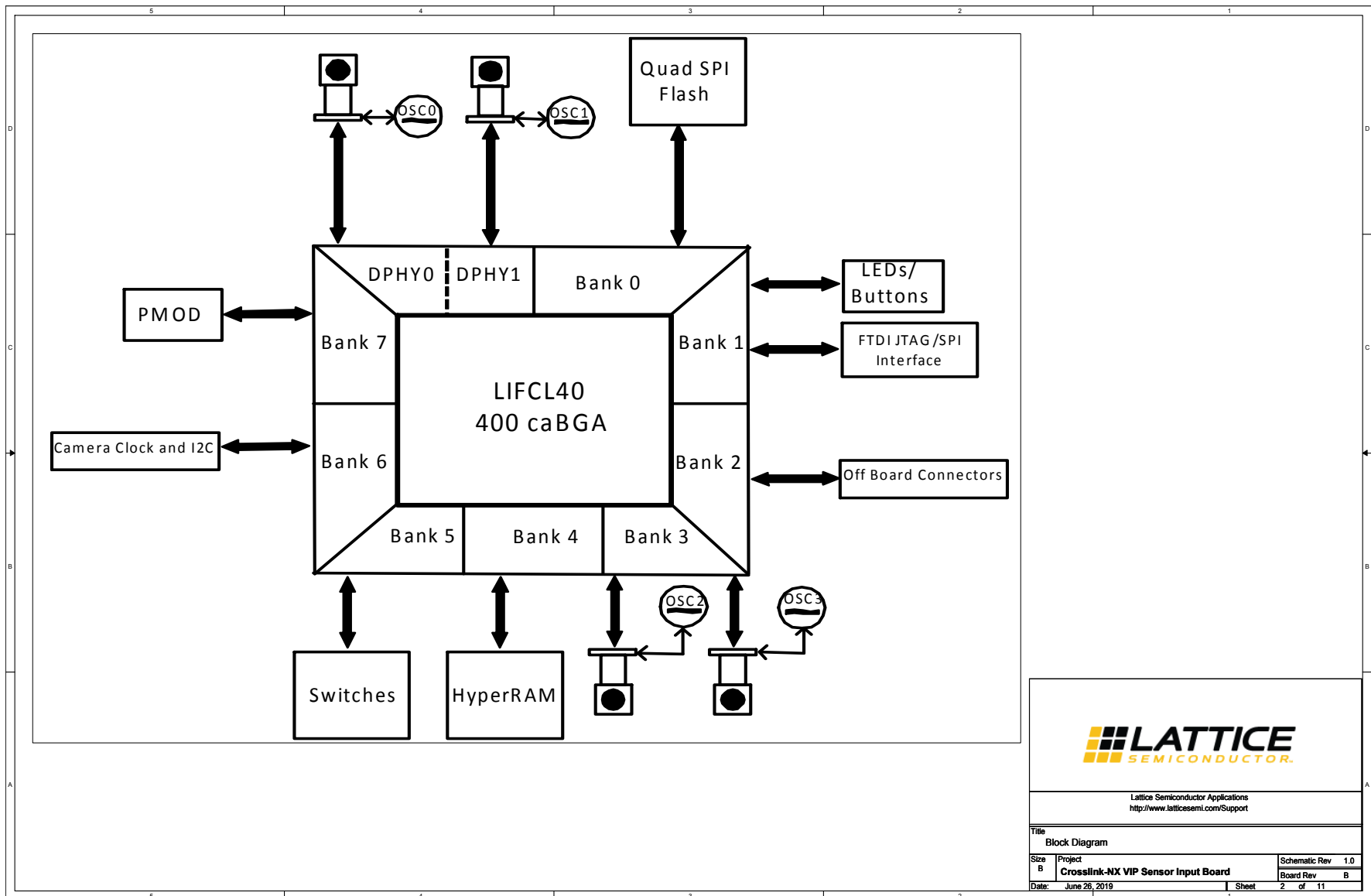

Figure A.2. Block Diagram

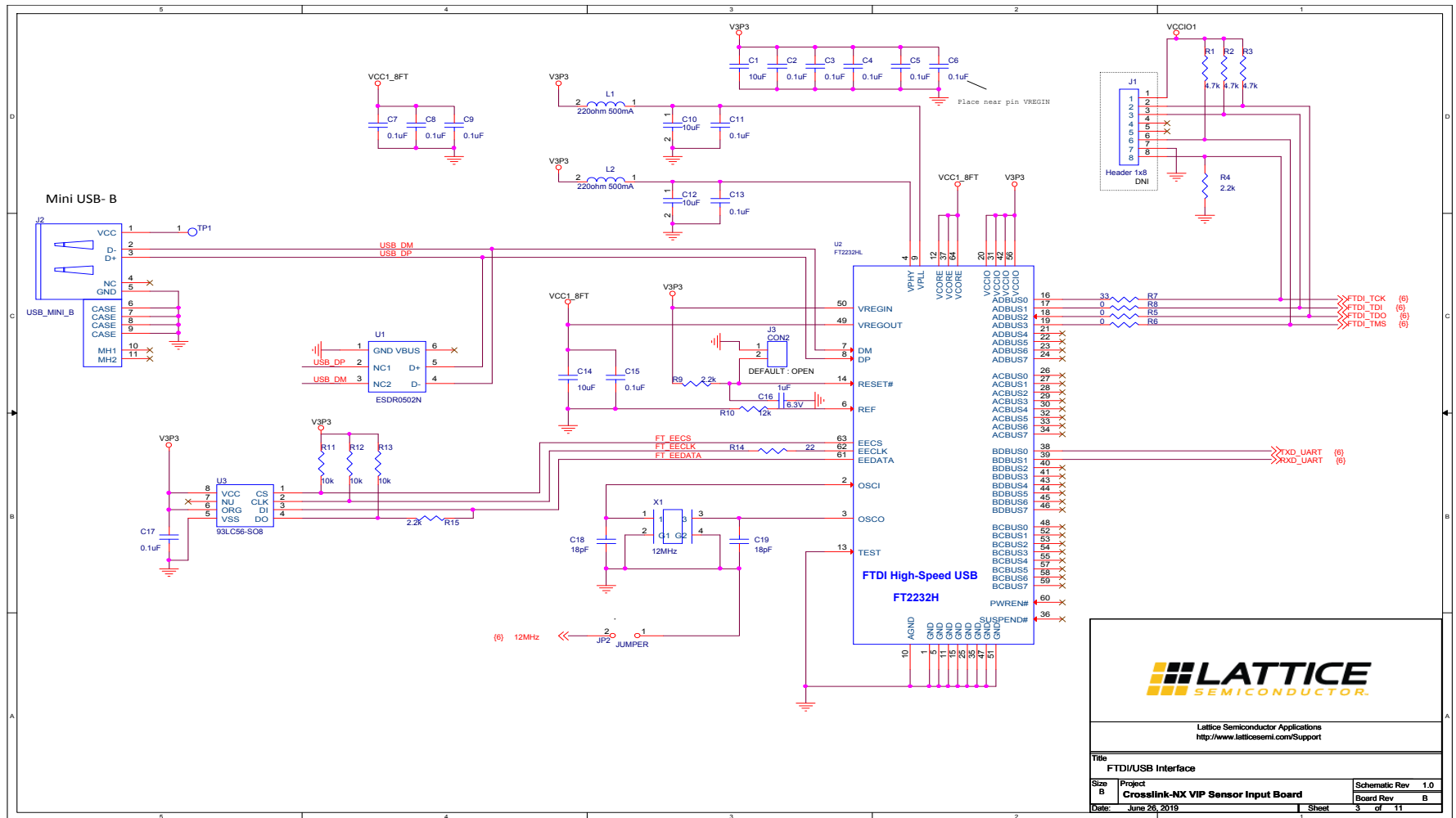

Figure A.3. FTDI/USB Interface

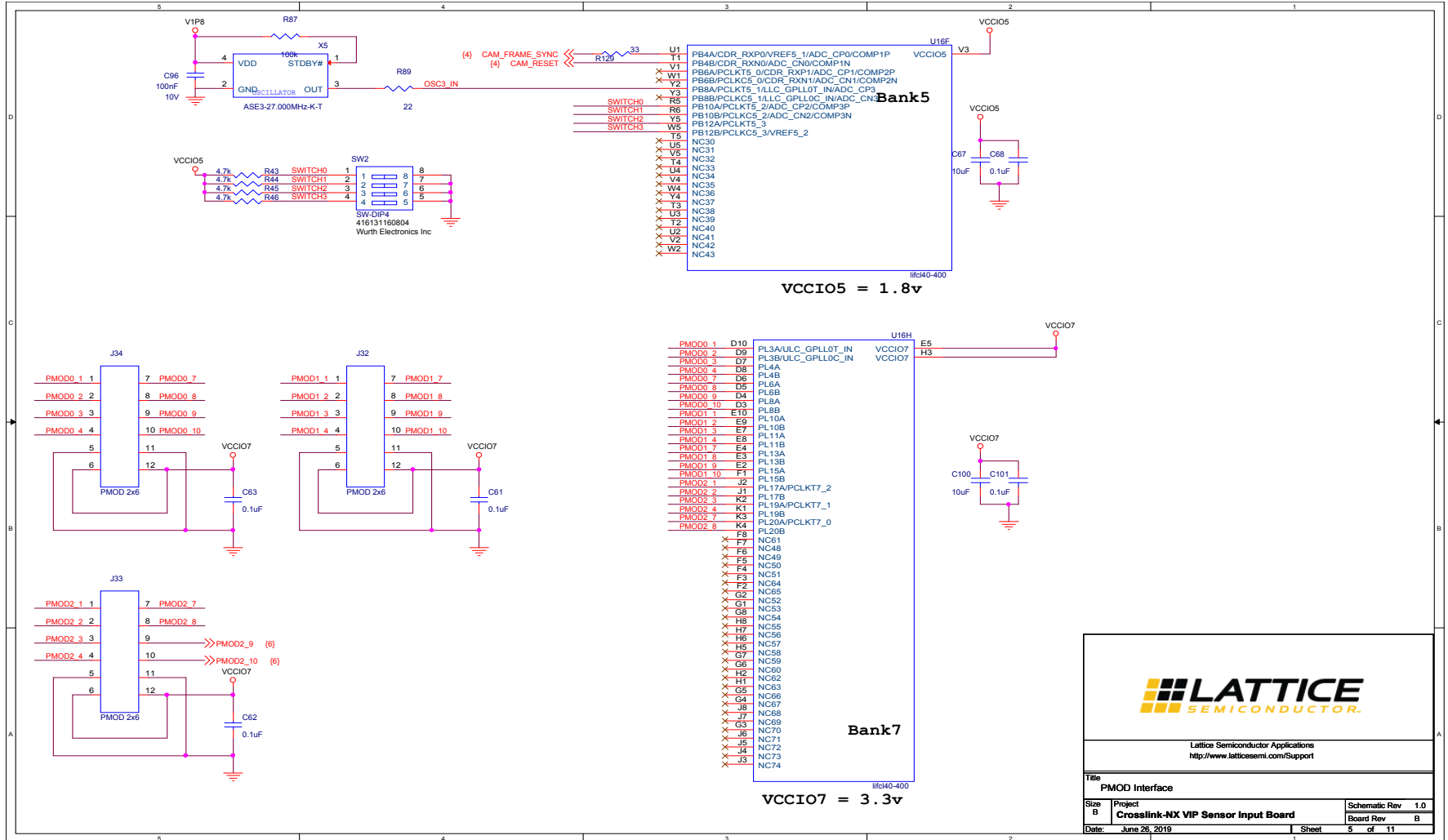
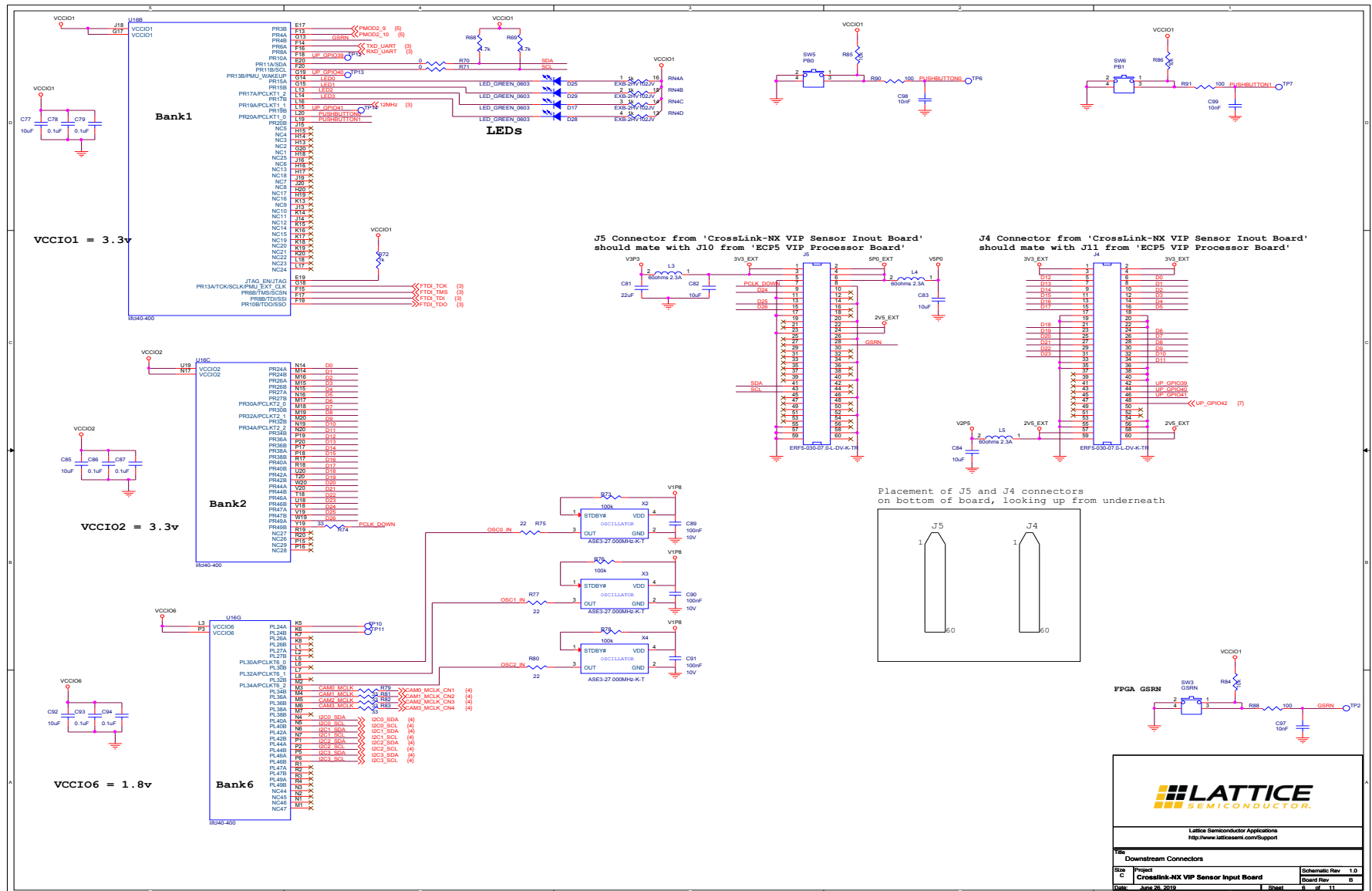

Figure A.5. PMOD Interface



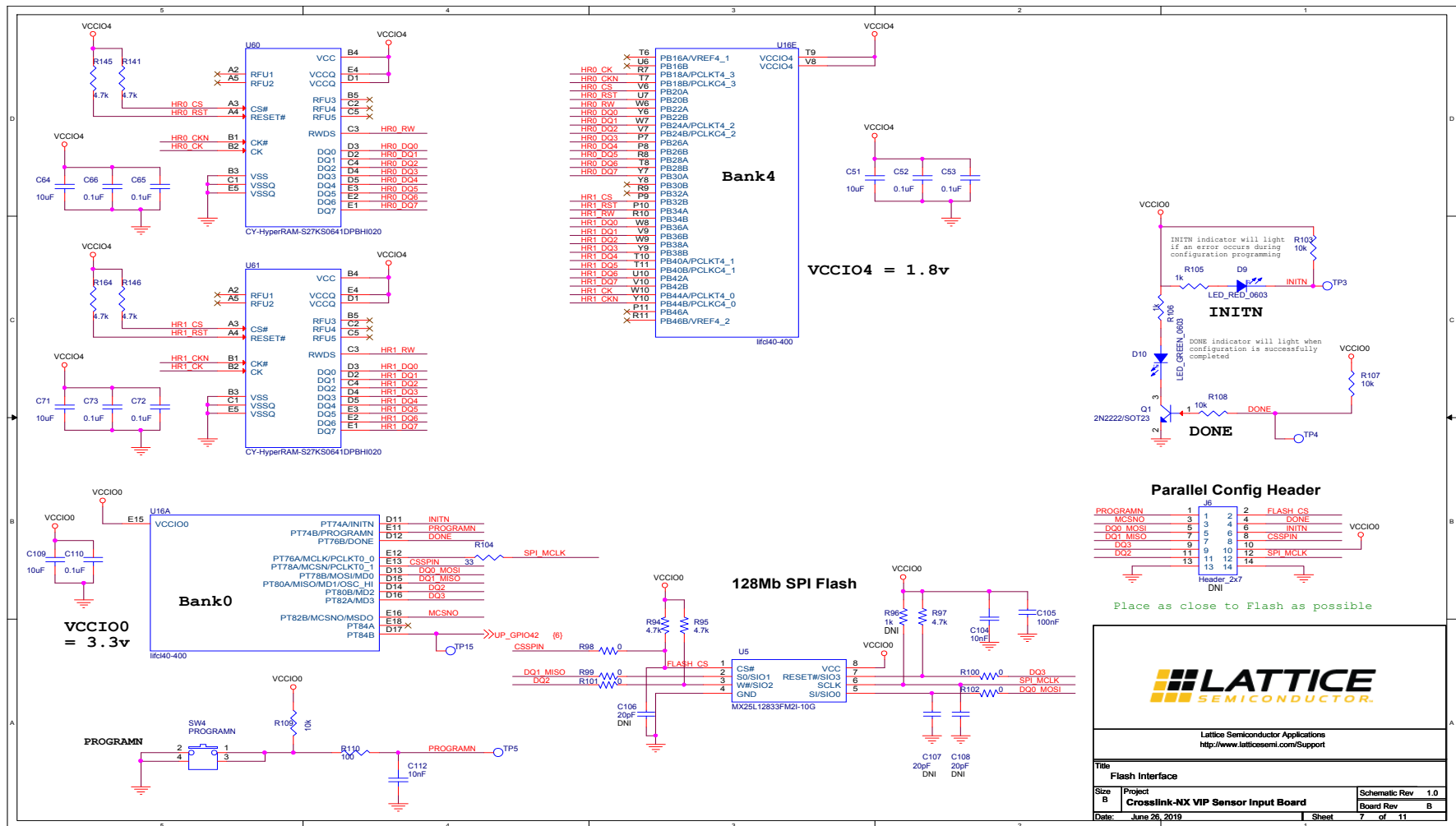

Figure A.7. Flash Interface

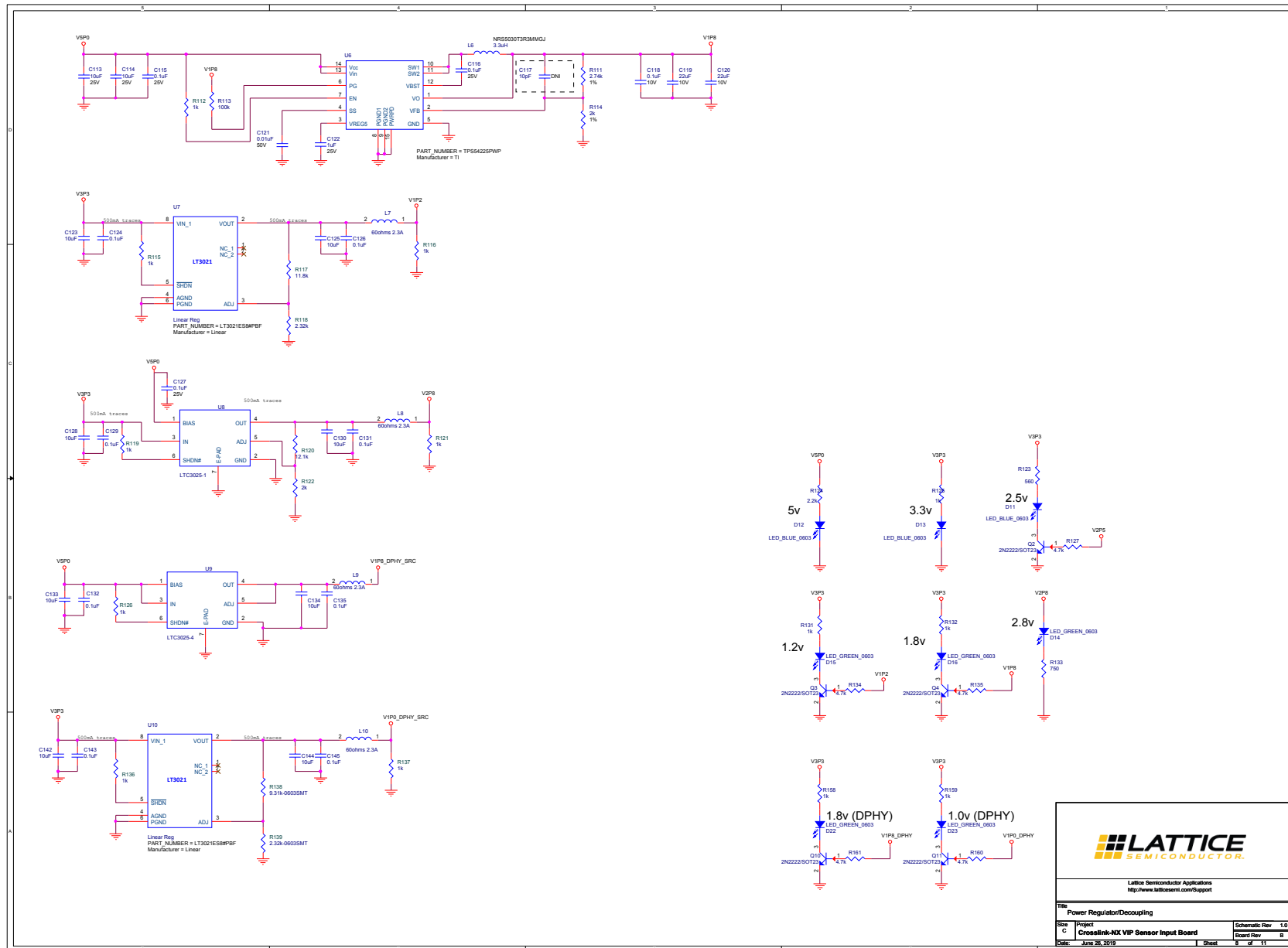

Figure A.8. Power Regulator/Decoupling

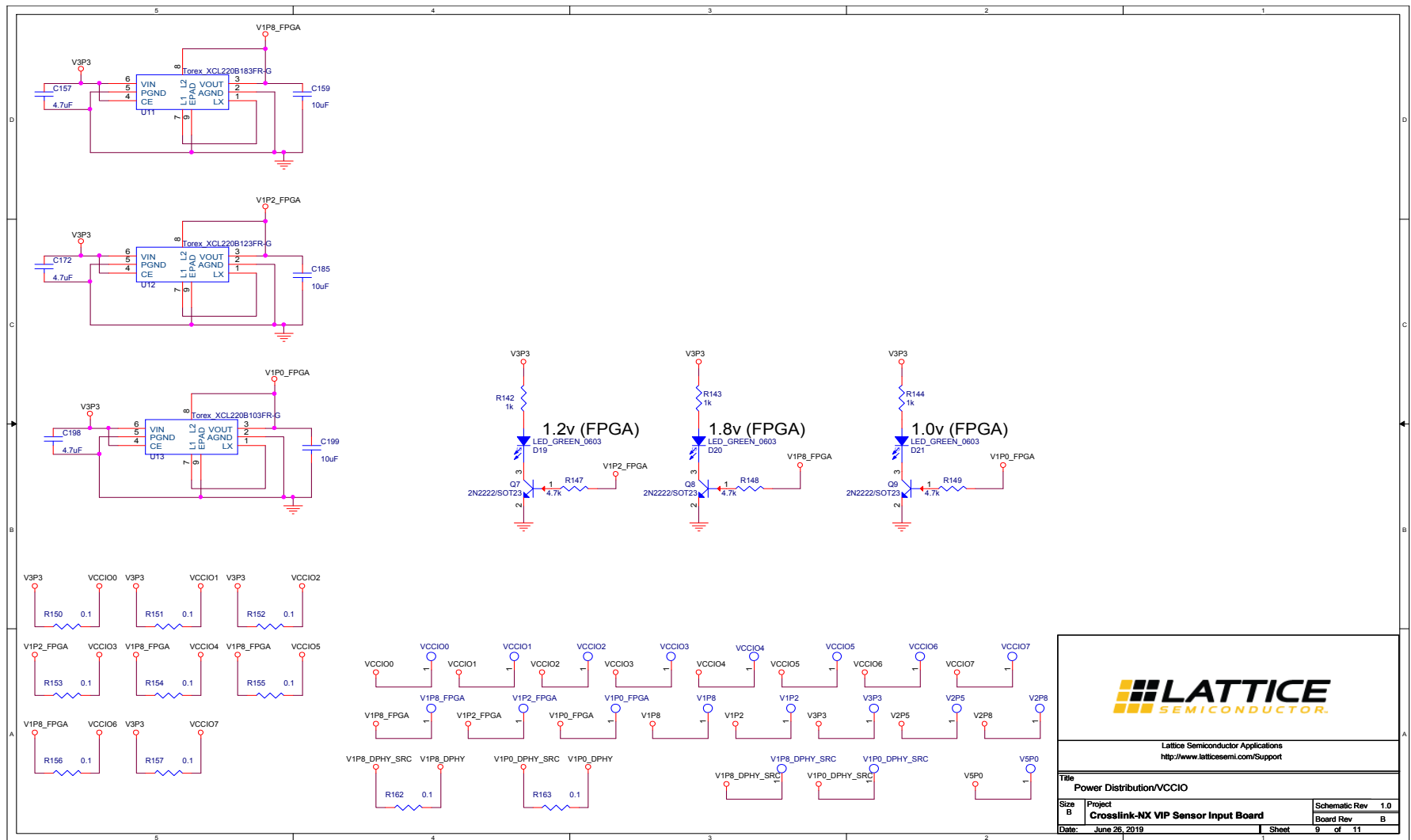

Figure A.9. Power Distribution/VCCIO

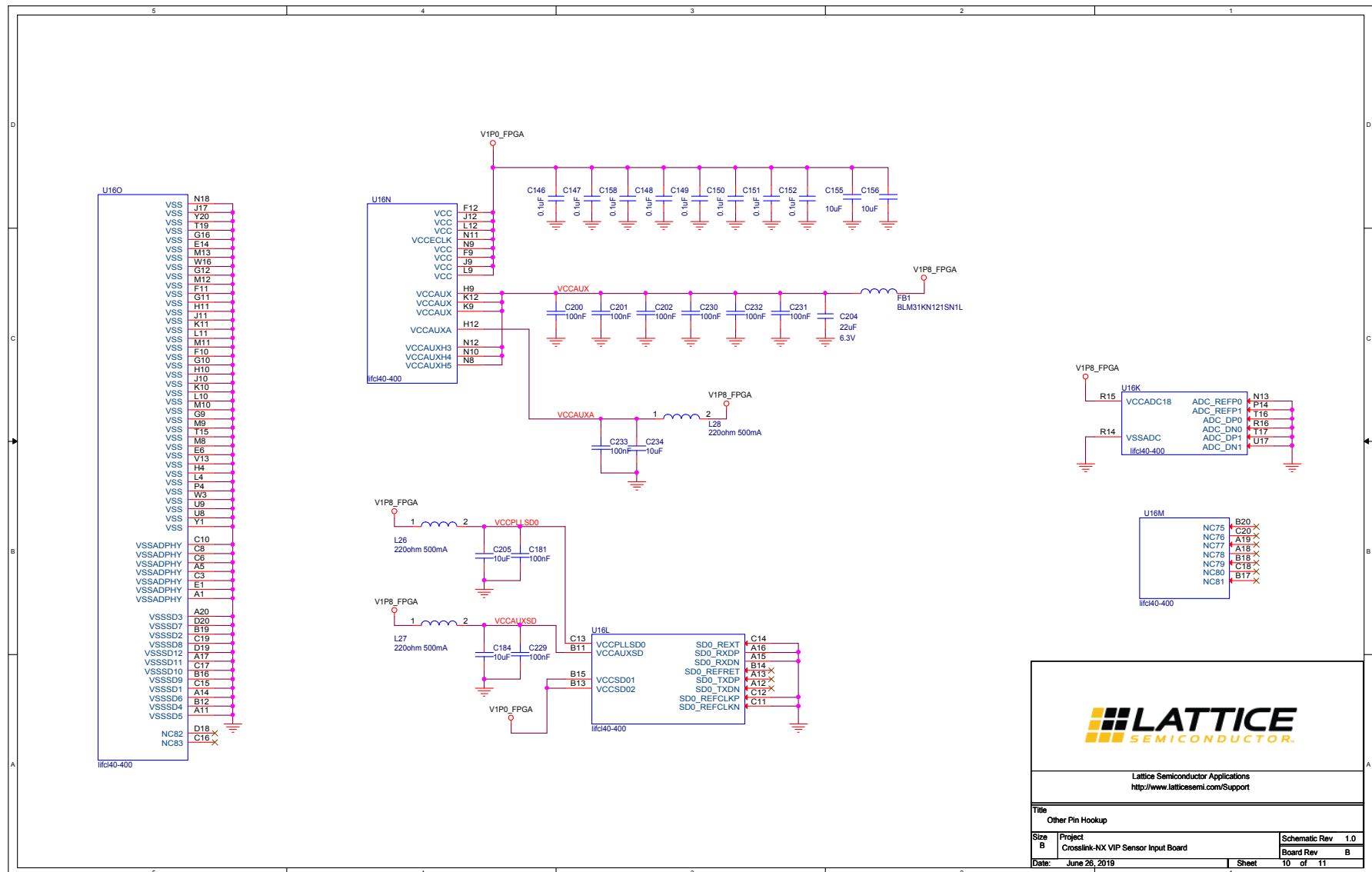

Figure A.10. Other Pin Hookup

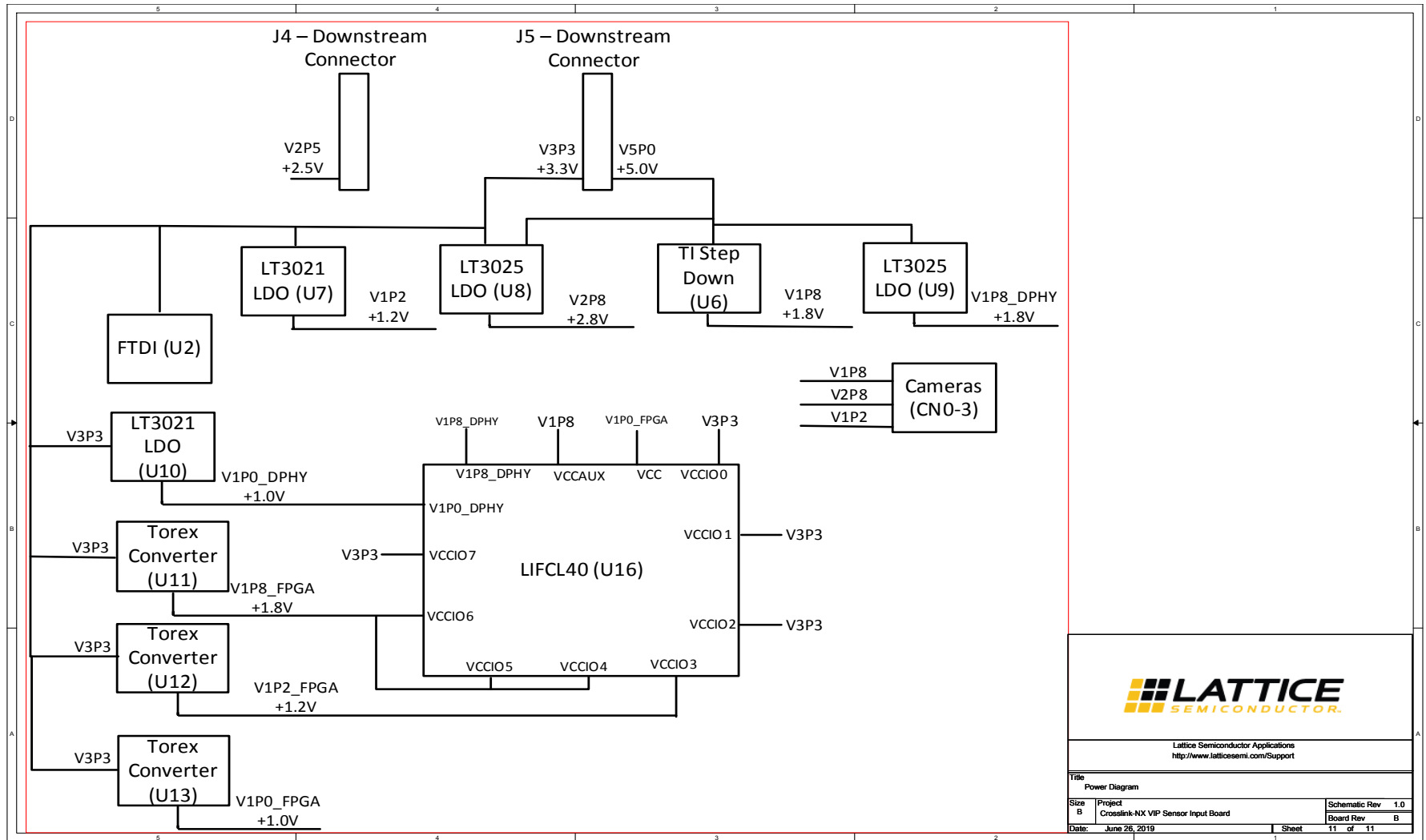

Figure A.11. Power Diagram

Appendix B. CrossLink-NX VIP Sensor Input Board Bill of Materials

Item	Reference	Qty	Part	PCB Footprint	Comments	Part Number	Manufacturer	Description
1	CN1,CN2,CN4,CN0	4	camconn_imx258_1x30	camconn	—	24-5804-030-000-829+	Kyocera / Sunny Optical	Sony IMX258 CSI Camera sensor
2	C1,C14	2	10uF	C0603	—	CL10A106KP8NNNC	Samsung	CAP CER 10UF 10V X5R 0603
3	C2,C3,C4,C5,C6,C7,C8,C9,C11,C13,C15,C17	12	0.1uF	C0402	—	CL05B104KA5NNNC	Samsung	CAP CER 0.1UF 25V 10% X7R 0402
4	C10,C12	2	10uF	C0603	—	CL10A106KP8NNNC	Samsung	CAP CER 10UF 10V X5R 0603
5	C16	1	1uF	C0402	—	GRM152R60J105ME15D	Murata	CAP CER 1UF 6.3V X5R 0402
6	C18,C19	2	18pF	C0402	—	C0402C180K3GAC7867	KEMET	CAP CER 18PF 25V NPO 0402
7	C20,C43,C69,C70,C80,C88	6	10uF	C0402	—	CL05A106MP8NUB8	Samsung	CAP CER 10UF 10V X5R 0402
8	C21,C22,C23,C27,C29,C31,C33,C35,C37,C39,C41,C42,C46,C48,C50,C52,C53,C54,C56,C58,C60,C65,C66,C68,C72,C73,C78,C79,C86,C87,C93,C94,C95,C101,C110,C146,C147,C148,C149,C150,C151,C152,C158	43	0.1uF	C0201	—	C0603X5R1C104K030BC	TDK	CAP CER 0.1UF 16V 10% X5R 0201
9	C28,C32,C34,C38,C45,C49,C55,C59	8	1uF	C0603	—	TMK107B7105KA-T	Taiyo Yuden	CAP CER 1UF 25V 10% X7R 0603
10	C30,C36,C40,C47,C51,C57,C64,C67,C71,C77,C82,C83,C84,C85,C92,C100,C109	17	10uF	C0603	—	CL10A106KP8NNNC	Samsung	CAP CER 10UF 10V X5R 0603
11	C44,C97,C98,C99,C104,C112	6	10nF	RLP-130-A	—	C0402C103J5RACTU	KEMET	CAP CER 10000PF 50V X7R 0402
12	C61,C62,C63	3	0.1uF	cc0402	—	C0402C104K4RACTU	Kemet	CAP CER 0.1UF 16V 10% X7R 0402
13	C81	1	22uF	C0603	—	CL10A226MQ8NRNC	Samsung	CAP CER 22UF 6.3V X5R 0603
14	C89,C90,C91,C96	4	100nF	C0402	—	CL05B104KA5NNNC	Samsung	CAP CER 0.1UF 25V 10% X7R 0402
15	C105,C200,C202,C230,C231	5	100nF	RLP-130-A	—	CL05B104KA5NNNC	Samsung	CAP CER 0.1UF 25V 10% X7R 0402

Item	Reference	Qty	Part	PCB Footprint	Comments	Part Number	Manufacturer	Description
16	C106,C107,C108	3	20pF	RLP-132	DNL	—	—	—
17	C113,C114	2	10uF	C1206	—	TMK316B7106 KL-TD	Taiyo Yuden	CAP CER 10UF 25V X7R 1206
18	C115,C116,C127	3	0.1uF	C0402	—	CL05B104KA5 NNNC	Samsung	CAP CER 0.1UF 25V 10% X7R 0402
19	C117	1	10pF	C0402	DNL	—	—	—
20	C118	1	0.1uF	C0402	—	CL05B104KA5 NNNC	Samsung	CAP CER 0.1UF 25V 10% X7R 0402
21	C119,C120	2	22uF	C1206	—	GRM31CR71A 226KE15L	MURATA	CAP CER 22UF 10V 10% X7R 1206
22	C121	1	0.01uF	C0402	—	C0402C103J5R ACTU	KEMET	CAP CER 10000PF 50V X7R 0402
23	C122	1	1uF	C0603	—	TMK107B7105 KA-T	Taiyo Yuden	CAP CER 1UF 25V 10% X7R 0603
24	C123,C125,C128,C130,C133,C134,C142, C144	8	10uF	C0603	—	CL10A106KP8 NNNC	Samsung	CAP CER 10UF 10V X5R 0603
25	C124,C126,C129,C131,C132,C135,C143, C145	8	0.1uF	C0402	—	CL05B104KA5 NNNC	Samsung	CAP CER 0.1UF 25V 10% X7R 0402
26	C155,C156,C159,C184,C185,C199,C205,C2 34	8	10uF	C0402	—	GRM155R60J1 06ME15D	Murata	CAP CER 10UF 6.3V X5R 0402
27	C157,C172,C198	3	4.7uF	C0402	—	CL05A475MO 5NUNC	Samsung	CAP CER 4.7UF 16V X5R 0402
28	C181,C201,C229,C232,C233	5	100nF	C0201	—	C0603X5R1C1 04K030BC	TDK	CAP CER 0.1UF 16V 10% X5R 0201
29	C204	1	22uF	C0402	—	CL05A226MQ 5QUNC	Samsung	CAP CER 22UF 6.3V X5R 0402

Item	Reference	Qty	Part	PCB Footprint	Comments	Part Number	Manufacturer	Description
30	D9	1	LED_RED_0603	APT1608	—	150060RS75000	Würth	LED RED CLEAR 0603 SMD
31	D10,D14,D15,D16,D17,D19,D20,D21,D22,D23,D25,D28,D29	13	LED_GREEN_0603	APT1608	—	150060GS75000	Würth	LED GREEN CLEAR 0603 SMD
32	D11,D12,D13	3	LED_BLUE_0603	APT1608	—	150060BS75000	Würth	LED BLUE CLEAR 0603 SMD
33	FB1	1	BLM31KN121SN1L	BLM41P	—	BLM31KN121SN1L	Murata	FERRITE BEAD 120 OHM 1206 1LN
34	JP2	1	JUMPER	Header_1x2	Regular 100Mil Header	—	—	—
35	J1	1	Header 1x8	hdr_amp_87220_8_1x8_100	DNL	22284081	Molex	CONN HEADER VERT 8POS 2.54MM
36	J2	1	USB_MINI_B	TYPE_B	—	1734035-2	TE Connectivity	CONN RCPT USB2.0 MINI B SMD R/A
37	J3	1	CON2	CON2	—	61300211121	Würth	CONN HEADER VERT 2POS 2.54MM
38	J4,J5	2	ERF5-030-07.0-L-DV-K-TR	ERF5-030-07.0-L-DV-K-TR	—	ERF5-030-07.0-L-DV-K-TR	Samtec Inc	.5MM EDGE RATE SOCKET ASSEMBLY
39	J6	1	Header_2x7	Header_2x7	DNL	—	—	—
40	J32,J34	2	PMOD 2x6	skt_sullins_pppc062_2x6_100	—	PPPC062LFBN-RC	Sullins	CONN HDR 12POS 0.1 GOLD PCB
41	J33	1	PMOD 2x6	skt_sullins_pppc062_2x6_100_1	—	PPPC062LFBN-RC	Sullins	CONN HDR 12POS 0.1 GOLD PCB
42	L1,L2,L26,L27,L28	5	220ohm 500mA	FB0603	—	BLM18AG221SN1D	Murata	FERRITE BEAD 220 OHM 0603 1LN
43	L3,L4,L5	3	60ohms 2.3A	FB0603	—	MPZ1608Y600B	TDK	FERRITE BEAD 60 OHM 0603 1LN
44	L6	1	3.3uH	IND_NRS50	—	NRS5030T3R3MMGJ	TAIYO YUDEN	FIXED IND 3.3UH 3A 30 MOHM SMD

Item	Reference	Qty	Part	PCB Footprint	Comments	Part Number	Manufacturer	Description
45	L7,L8,L9,L10	4	60ohms 2.3A	FB0603	—	MPZ1608Y600 B	TDK	FERRITE BEAD 60 OHM 0603 1LN
46	L29,L30,L33,L34,L35,L36	6	220ohm 500mA	FB0402	—	BLM15AX221S N1D	Murata	FERRITE BEAD 220 OHM 0402 1LN
47	Q1,Q2,Q3,Q4,Q7,Q8,Q9,Q10,Q11	9	2N2222/SOT23	MMBT2222 ALT-1	—	MMBT2222AL T1G	ON Semiconductor	TRANS NPN 40V 0.6A SOT23
48	RN4	1	EXB-2HV102JV	EXB-2HV	—	EXB-2HV102JV	Panasonic	RES ARRAY 8 RES 1K OHM 1506
49	R1,R2,R3,R68,R69,R94,R95,R97,R127, R134,R135,R147,R148,R149,R160,R161	16	4.7k	R0402	—	ERJ-2GEJ472X	Panasonic	RES SMD 4.7K OHM 5% 1/10W 0402
50	R4,R9,R15,R124	4	2.2k	R0402	—	ERJ-2RKF2201X	Panasonic	RES SMD 2.2K OHM 1% 1/10W 0402
51	R5,R6,R8,R70,R71,R98,R99,R100,R101, R102	10	0	R0402	—	ERJ-2GE0R00X	Panasonic	RES SMD 0.0OHM JUMPER 1/10W 0402
52	R7,R74,R79,R81,R82,R83,R104	7	33	R0402	—	ERJ-2RKF33R0X	Panasonic	RES SMD 33 OHM 1% 1/10W 0402
53	R10	1	12k	R0402	—	ERJ-2RKF1202X	Panasonic	RES SMD 12K OHM 1% 1/10W 0402
54	R11,R12,R13,R37,R84,R85,R86,R103, R107,R108,R109	11	10k	R0402	—	RC0402FR-0710KL	Yageo	RES SMD 10K OHM 1% 1/16W 0402
55	R14,R75,R77,R80,R89	5	22	R0402	—	ERJ-2RKF22R0X	Panasonic	RES SMD 22 OHM 1% 1/10W 0402
56	R16,R17,R23,R24,R35,R36,R47,R48	8	4.7k	R0402	—	ERJ-2GEJ472X	Panasonic	RES SMD 4.7K OHM 5% 1/10W 0402
57	R18,R19,R20,R21,R22,R25,R26,R27,R28, R29,R30,R31,R32,R33,R34,R49,R50,R51, R52,R53	20	100	R0402	DNL	RC0402FR-07100RL	Yageo	RES SMD 100 OHM 1% 1/16W 0402
58	R38,R88,R90,R91,R110,R128	6	100	R0402	---	RC0402FR-07100RL	Yageo	RES SMD 100 OHM 1% 1/16W 0402

Item	Reference	Qty	Part	PCB Footprint	Comments	Part Number	Manufacturer	Description
59	R39,R40,R41,R42,R129	5	33	R0201	—	RC0201FR-0733RL	Yageo	RES SMD 33 OHM 1% 1/20W 0201
60	R43,R44,R45,R46	4	4.7k	R0402	—	ERJ-2GEJ472X	Panasonic	RES SMD 4.7K OHM 5% 1/10W 0402
61	R72	1	1k	R0402	—	ERJ-2RKF1001X	Panasonic	RES SMD 1K OHM 1% 1/10W 0402
62	R73,R76,R78,R87	4	100k	R0402	—	ERJ-2RKF1003X	Panasonic	RES SMD 100K OHM 1% 1/10W 0402
63	R96	1	1k	R0402	DNL	ERJ-2RKF1001X	Panasonic	RES SMD 1K OHM 1% 1/10W 0402
64	R105,R106,R112,R115,R116,R119,R121,R125,R126,R131,R132,R136,R137,R142,R143,R144,R158,R159	18	1k	R0402	—	ERJ-2RKF1001X	Panasonic	RES SMD 1K OHM 1% 1/10W 0402
65	R111	1	2.74k	R0603	—	ERJ-3EKF2741V	Panasonic	RES SMD 2.74K OHM 1% 1/10W 0603
66	R113	1	100k	R0402	—	ERJ-2RKF1003X	Panasonic	RES SMD 100K OHM 1% 1/10W 0402
67	R114,R122	2	2k	R0603	—	ERJ-3EKF2001V	Panasonic	RES SMD 2K OHM 1% 1/10W 0603
68	R117	1	11.8k	R0603	—	ERJ-3EKF1182V	Panasonic	RES SMD 11.8K OHM 1% 1/10W 0603
69	R118	1	2.32k	R0603	—	ERJ-3EKF2321V	Panasonic	RES SMD 2.32K OHM 1% 1/10W 0603
70	R120	1	12.1k	R0603	—	ERJ-3EKF1212V	Panasonic	RES SMD 12.1K OHM 1% 1/10W 0603
71	R123	1	560	R0402	—	ERJ-2GEJ561X	Panasonic	RES SMD 560 OHM 5% 1/10W 0402
72	R133	1	750	R0402	—	ERJ-2GEJ751X	Panasonic	RES SMD 750 OHM 5% 1/10W 0402
73	R138	1	9.31k-0603SMT	R0603	—	ERJ-3EKF9311V	Panasonic	RES SMD 9.31K OHM 1% 1/10W 0603
74	R139	1	2.32k-0603SMT	R0603	—	ERJ-3EKF2321V	Panasonic	RES SMD 2.32K OHM 1% 1/10W 0603
75	R141,R145,R146,R164	4	4.7k	R0603	—	CRCW06034K70FKEA	Vishay	RES SMD 4.7K OHM 1% 1/10W 0603
76	R150,R151,R152,R153,R154,R155,R156,R157,R162,R163	10	0.1	R0603	—	RL0603FR-070R1L	Yageo	RES 0.1 OHM 1% 1/10W 0603

Item	Reference	Qty	Part	PCB Footprint	Comments	Part Number	Manufacturer	Description
77	SW1	1	CAM_RST	4psmd_swit tch	—	43415301783 5	Würth	SWITCH TACTILE SPST-NO 0.05A 12V
78	SW2	1	SW-DIP4	416131160 804	—	41613116080 4	Würth Electronics Inc	SWITCH SLIDE DIP SPST 25MA 24V
79	SW3	1	GSRN	4psmd_swit tch	—	43415301783 5	Würth	SWITCH TACTILE SPST-NO 0.05A 12V
80	SW4	1	PROGRAMN	4psmd_swit tch	—	43415301783 5	Würth	SWITCH TACTILE SPST-NO 0.05A 12V
81	SW5	1	PB0	4psmd_swit tch	—	43415301783 5	Würth	SWITCH TACTILE SPST-NO 0.05A 12V
82	SW6	1	PB1	4psmd_swit tch	—	43415301783 5	Würth	SWITCH TACTILE SPST-NO 0.05A 12V
83	VCCIO1,TP1,VCCIO2,VCCIO3,VCCIO4, VCCIO5,VCCIO6,VCCIO7,V1P0_FPGA, V1P0_DPHY_SRC,V1P2_FPGA,V1P2, V1P8_FPGA,V1P8_DPHY_SRC,V1P8,V2P5, V2P8,V3P3,V5P0,VCCIO0	20	TP_S_40_63	tp_s_40_63	DNL	—	—	Square test point, 40mil inner diameter, 63mil outer diameter
84	TP2,TP3,TP4,TP5,TP6,TP7,TP8,TP9,TP10, TP11,TP12,TP13,TP14,TP15	14	TestPoint	TP50	DNL	—	—	—
85	U1	1	ESDR0502N	ESDR0502N	—	ESDR0502NM UTBG	ON Semiconductor	TVS DIODE 5.5VWM 6UDFN
86	U2	1	FT2232HL	tqfp64_0p5 _12p2x12p 2_h1p6	—	FT2232HL- REEL	FTDI	IC USB HS DUAL UART/FIFO 64-LQFP
87	U3	1	93LC56-SO8	so8_50_24 4	—	93LC56C-I/SN	Microchip Technology	IC EEPROM 2K SPI 3MHZ 8SOIC
88	U5	1	MX25L12833F M2I-10G	SO8_MX25 L12833FM2 I10G	—	MX25L12833F M2I-10G	Macronix	IC FLASH 128MBIT 104MHZ 8SOP
89	U6	1	TPS54225PWP	14HTSSOP_ TPS542	—	TPS54225PWP	TI	IC REG BUCK ADJ 2A SYNC 14HTSSOP
90	U7,U10	2	Linear Reg	8SOIC_LT3 021	—	LT3021ES8#PB F	Linear	IC REG LIN POS ADJ 500MA 8SOIC
91	U8	1	LTC3025-1	LTC3025- DFN	—	LTC3025EDC- 1#PBF	Linear Tech	IC REG LDO ADJ 0.5A 6DFN
92	U9	1	LTC3025-4	LTC3025- DFN	—	LTC3025EDC- 4#TRMPBF	Linear Tech	IC REG LINEAR 1.8V 500MA 6DFN

Item	Reference	Qty	Part	PCB Footprint	Comments	Part Number	Manufacturer	Description
93	U11	1	Torex_XCL220 B183FR-G	XCL220B18 3FR-G	—	XCL220B183F R-G	Torex	DC CONVERTER 1.8V
94	U12	1	Torex_XCL220 B123FR-G	XCL220B12 3FR-G	—	XCL220B123F R-G	Torex	DC CONVERTER 1.2V
95	U13	1	Torex_XCL220 B103FR-G	XCL220B12 3FR-G	—	XCL220B103F R-G	Torex	DC CONVERTER 1V 1A
96	U16	1	lifcl-40	lifcl-40	Customer Supplied	—	—	—
97	U60,U61	2	CY- HyperRAM- S27KS0641DP BHI020	24FBGA_S2 7KS	—	S27KS0641DP BHI020	Cypress	IC DRAM 64M PARALLEL 24BGA
98	X1	1	12MHz	crystal_4p_ 3p2x2p5	—	7M- 12.000MAAJ-T	TXC	CRYSTAL 12.000MHZ 18PF SMD
99	X2,X3,X4,X5	4	ASE3-27.000 MHz-K-T	27MHZ	—	ASE3- 27.000MHZ-K- T	ABRACON	XTAL OSC XO 27.000MHZ CMOS SMD
100	CN1,CN2,CN0,CN4	4	Camera Module with IMX214	—	Customer Supplied	—	—	Camera Module with IMX214

References

For more information, refer to

- [CrossLink-NX Family Data Sheet \(FPGA-DS-02049\)](#)
- [Lattice Embedded Vision Development Kit User Guide \(FPGA-UG-02015\)](#)
- [ECP5 VIP Processing Board \(FPGA-EB-02001\)](#)
- [HDMI VIP Output Bridge Board \(FPGA-EB-02003\)](#)

Technical Support Assistance

Submit a technical support case through www.latticesemi.com/techsupport.

Revision History

Revision 1.1, September 2020

Section	Change Summary
CrossLink-NX Interface Support	<ul style="list-style-type: none">Updated the camera configuration description and Figure 4.1. Camera Sensor Interface in Camera Sensor Interface.Updated the I²C camera configuration path from ECP5 in Upstream Connector Interface.

Revision 1.0, December 2019

Section	Change Summary
All	Initial release.



www.latticesemi.com