

TECHNICAL INFORMATION

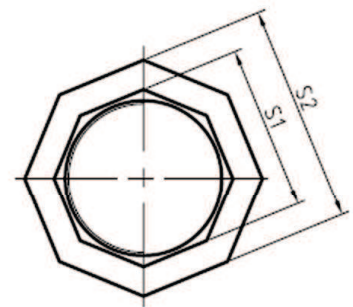

Type 95
Union Elbow 90° flat seat F/F
UA1

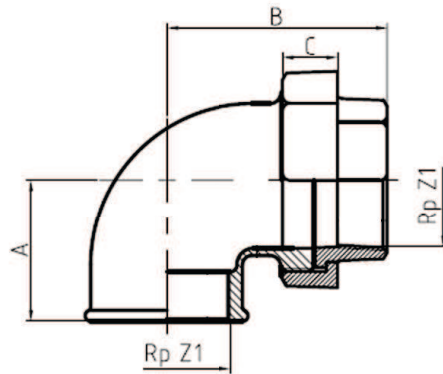

SIZE	A [mm]	B [mm]	C [mm]	S1 [mm]	S2max [mm]	Rp Z1
3/8"	25	52	17	21,2	36	3/8"
1/2"	28	58	18	25	41	1/2"
3/4"	33	62	20	31	50	3/4"
1"	38	72	22	38	55	1"
1 1/4"	45	82	24	48	70	1 1/4"
1 1/2"	50	90	25	53,5	75	1 1/2"
2"	58	100	27	66,6	90	2"

Technical characteristics:

- products according to DIN EN 10242, Design Symbol A
- certified by DVGW CERT