



CORE DRILLING TECHNOLOGY CATALOGUE

FASCINATION  PRECISION®

The new RUKO
core drilling machines

RU 40

RU 25

from page 04

Accessories

from page 12

**OUT
NOW**



RUKO CORE DRILLING TECHNOLOGY



The RUKO core drilling machine RU40 - Technical features.

Standard fine adjustment stabilised
Displaceability: ± 10 mm
Pivoting range: $\pm 30^\circ$

The RUKO fine adjustment enables repositioning
with fixed magnets.

Better handling due to ergonomic carrying handle.

Coolant bottle with intelligent coolant supply.

Magnet with 20.000 N clamping force and larger
contact surface.



RU 40

- 20.000 N clamping force
 - Height-adjustable power unit with double dovetail guide
 - Right-/ left-handed rotation
 - 4-speed gearbox
 - Speed controller
 - High-performance motor
 - Standard fine adjustment stabilised
- Displaceability: ± 10 mm
Pivoting range: $\pm 30^\circ$



Art. no. 108 040 RU

Technical data:



Magnetic clamping force:
20.000 N



Weight:
22,0 kg



Thread cutting:
M 3 - M 30



Total Power consumption:
1.800 Watt



Adapter:
Morse taper MT 3



Cutting depth core drills:
bis 110,0 mm



Rotation speeds:
50 - 110 | 75 - 175 r.p.m.
105 - 245 | 165 - 385 r.p.m.



Drill chuck:
1,0 - 16,0 mm



Input voltage:
220 - 240 Volt



Height:
642,0 - 702,0 mm



Core drills:
 \varnothing 12,0 - 80,0 mm



Conformity with:
VDE, CEE



Lift:
190,0 mm



Countersinks:
 \varnothing 10,0 - 55,0 mm



Length and width:
238,0 x 92,0 mm



Twist drills:
DIN 338/1897: max. \varnothing 16,0 mm
DIN 345: max. \varnothing 32,0 mm



Accessories:

- 1 Plastic tool case
- 1 Allen key 2.5 / 6
- 1 Safety belt
- 1 Drill chuck \varnothing 1,0 - 16,0 mm
- 1 MT 3 arbor holder
- 1 Coolant bottle
- 1 High performance cutting oil spray
- 1 Operating instructions

Use of accessories for core drilling machine RU40

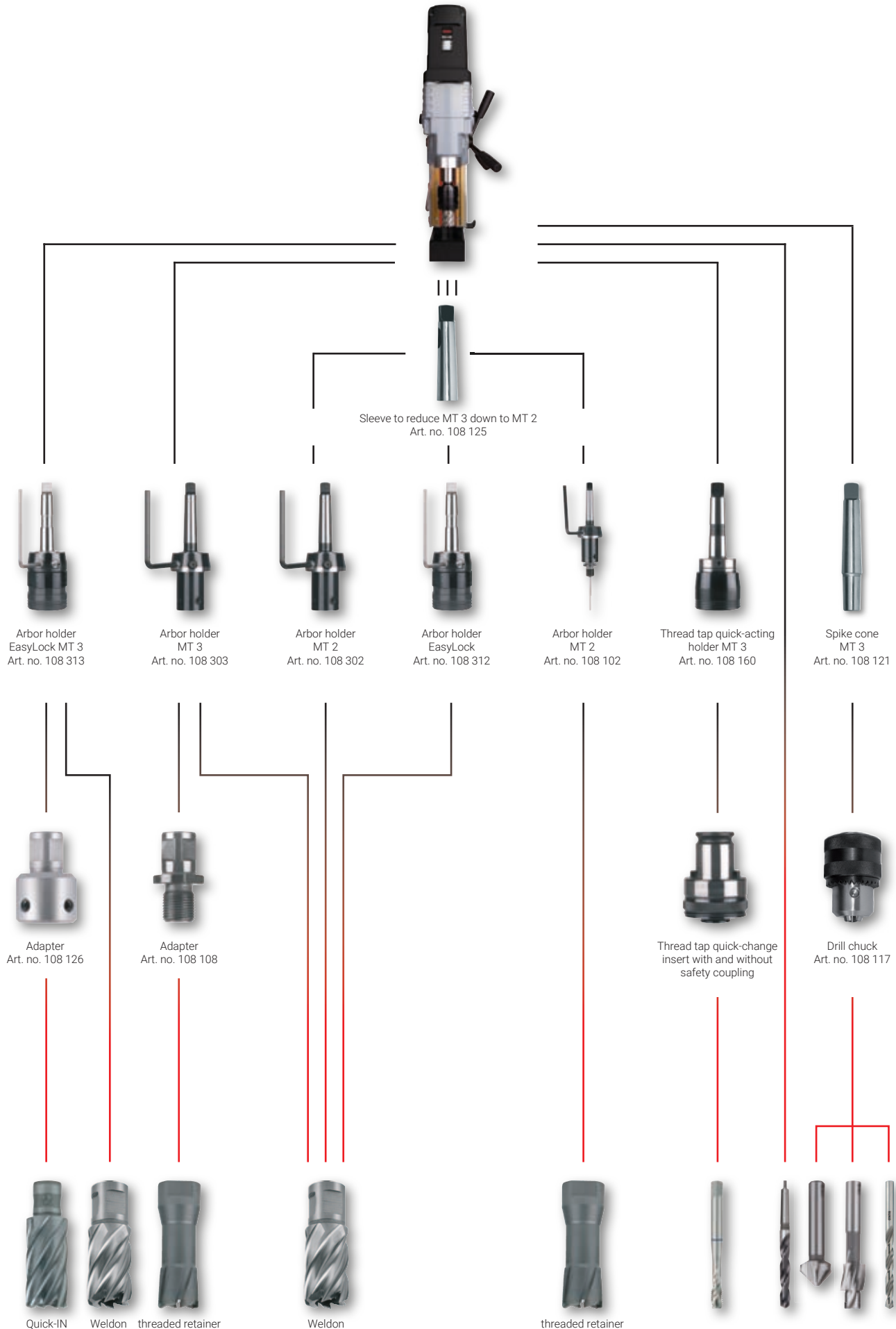

RU 25

- 16.000 N clamping force
- Height-adjustable power unit with double dovetail guide
- Right-/ left-handed rotation
- 2-speed gearbox
- Speed controller
- High-performance motor
- Light and handy



Art. no. 108 025 RU

Technical data:



Magnetic clamping force:
16.000 N



Weight:
16,0 kg



Thread cutting:
M 3 - M 20



Total Power consumption:
1.200 Watt



Adapter:
Morse taper MT 2



Cutting depth core drills:
up to 55,0 mm



Rotation speeds:
100 - 250 | 180 - 450 r.p.m.



Drill chuck:
1,0 - 16,0 mm



Input voltage:
220 - 240 Volt



Height:
529,0 - 629,0 mm



Core drills:
Ø 12,0 - 50,0 mm



Conformity with:
VDE, CEE



Lift:
170,0 mm



Countersinks:
Ø 10,0 - 40,0 mm



Length and width:
238,0 x 92,0 mm



Twist drills:
DIN 338/1897: max. Ø 16,0 mm
DIN 345: max. Ø 20,0 mm



Accessories:

- 1 Plastic tool case
- 1 Allen key 2.5 / 6
- 1 Safety belt
- 1 Drill chuck Ø 1,0 - 16,0 mm
- 1 MT 2 arbor holder
- 1 Coolant bottle
- 1 High performance cutting oil spray
- 1 Operating instructions



Use of accessories for core drilling machine RU25



Arbor holder
MT 2
Art. no. 108 302



Arbor holder
EasyLock
Art. no. 108 312



Arbor holder
MT 2
Art. no. 108 102



Thread tap quick-acting
holder MT 2
Art. no. 108 163



Spike cone
MT 2
Art. no. 108 120



Adapter
Art. no. 108 126



Adapter
Art. no. 108 108



Thread tap quick-change
insert with and without
safety coupling



Drill chuck
Art. no. 108 117



Quick-IN



threaded retainer



Weldon



threaded retainer



A10

- 10.000 N clamping force
- Height-adjustable power unit with double dovetail guide
- Very light / easy to use
- Automatic coolant supply
- Easy readjustment thanks to 50% reduction in magnetic power when the motor is switched off



Art. no. 108 010 A

Technical data:



Magnetic clamping force:
10.000 N



Length and width:
160,0 x 80,0 mm



Core drills:
Ø 12,0 - 35,0 mm



Total Power consumption:
1.100 Watt



Weight:
10,5 kg



Cutting depth core drills:
up to 50,0 mm



Rotation speeds:
700 r.p.m



Adapter:
Weldon: 19,0 mm (3/4")



Input voltage:
220 - 240 Volt



Height:
400,0 - 580,0 mm



Twist drills:
DIN 338: max. Ø 13,0 mm



Conformity with:
VDE, CEE



Lift:
120,0 / 195,0 mm

Accessories:

- 1 Plastic tool case
- 1 Arbor holder Weldon
- 1 Safety belt
- 3 Allen key 2.5 / 4 / 6
- 1 Coolant bottle
- 1 Operating instructions





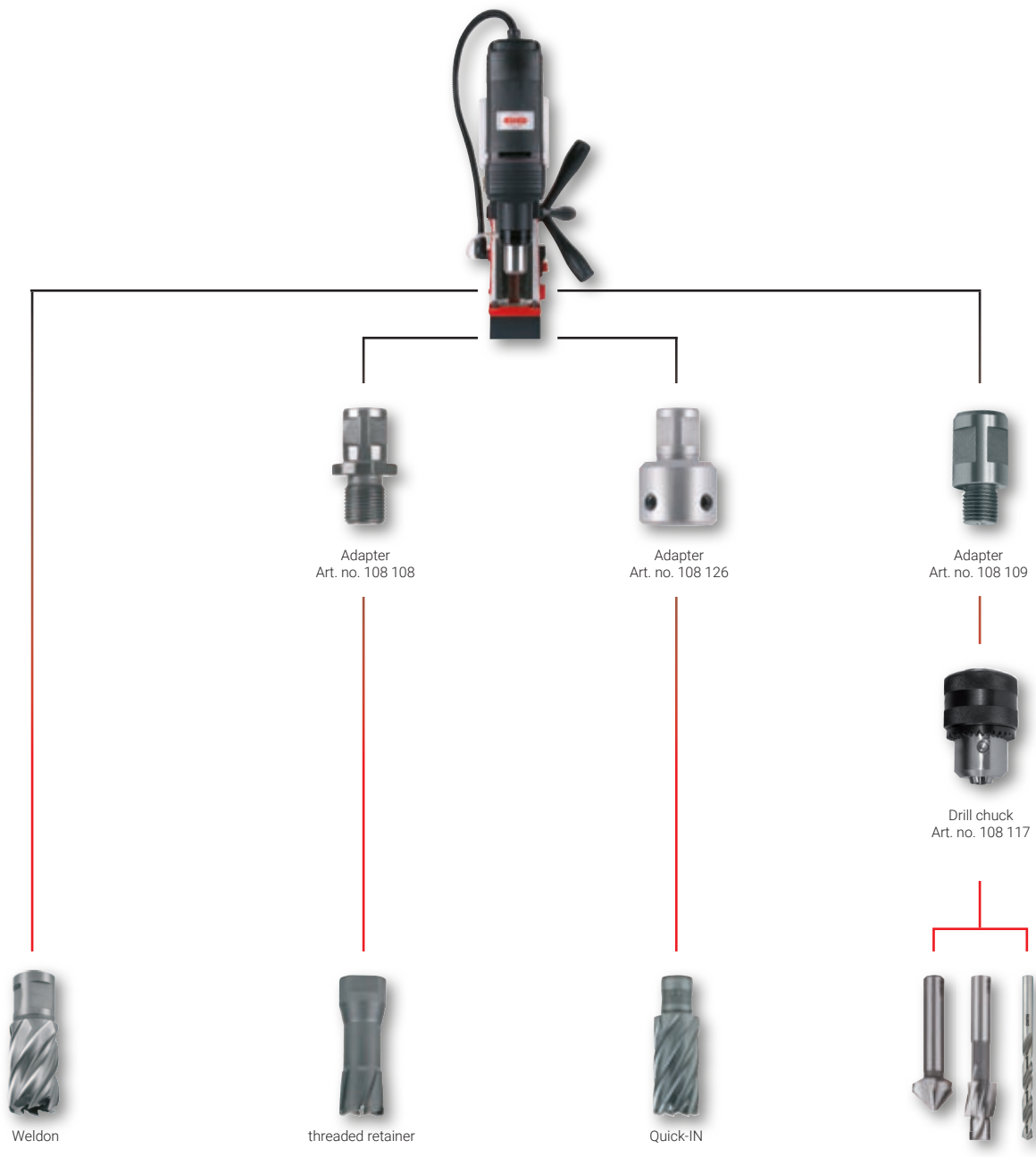



















Use of accessories for core drilling machine A10



Overview of RUKO core drilling machines

Comparison of technical data:

RU 40 Art. no.
108 040 RU

	Magnetic clamping force:	20.000 N
	Power consumption:	1.800 Watt
	Gears:	4 gears
	Rotation speeds r.p.m.:	50 - 110 75 - 175 105 - 245 165 - 385 r.p.m
	Electrical rotation controller:	✓
	Right-left-handed rotation:	✓
	Height:	642,0 - 702,0 mm
	Width:	238,0 x 92,0 mm
	Weight:	22,0 kg
	Lift:	190,0 mm
	Adapter:	Morse taper MT 3
	Core drills:	Ø 12,0 - 80,0 mm
	Drill chuck:	1,0 - 16,0 mm
	Twist drills DIN 338/1897:	max. Ø 16,0 mm
	Twist drills DIN 345:	max. Ø 32,0 mm
	Countersinks:	Ø 10,0 - 55,0 mm
	Cutting depth core drills:	max. 110,0 mm
	Input voltage:	220 – 240 V
	Conformity with:	VDE, CEE
	Displaceability:	+/- 10,0 mm
	Pivoting range:	+/- 30°
	Thread cutting:	✓
	Thread tap:	M 3 - M 30

Accessoires:



RU 40 Art. no.
108 040 RU

Plastic tool case
MT 3 arbor holder
Allen keys 2.5 / 6
Safety belt
Drill chuck 1,0 - 16,0 mm
Coolant bottle
High performance cutting oil spray
Operating instructions

RU25 Art. no.
108 025 RU

16.000 N

1.200 Watt

2 gears

100 - 250 | 180 - 450 r.p.m

✓

✓

529,0 - 629,0 mm

238,0 x 92,0 mm

16,0 kg

170,0 mm

Morse taper MT 2

Ø 12,0 - 50,0 mm

1,0 - 16,0 mm

max. Ø 16,0 mm

max. Ø 20,0 mm

Ø 10,0 - 40,0 mm

max. 55,0 mm

220 – 240 V

VDE, CEE

–

–

–

✓

M 3 - M 20

A 10 Art. no.
108 010 A

10.000 N

1.100 Watt

1 gear

700 r.p.m

–

–

400,0 - 580,0 mm

160,0 x 80,0 mm

10,5 kg

120,0 / 195,0 mm

Weldon shank 19,0 mm (3/4")

12,0 - 35,0 mm

3,0 - 16,0 mm

max. Ø 13,0 mm

–

–

max. 50,0 mm

220 – 240 V

VDE, CEE

–

–

–

–

–

RU25 Art. no.
108 025 RU

Plastic tool case

MT 2 arbor holder

Allen keys 2.5 / 6

Safety belt

Drill chuck 1,0 - 16,0 mm

Coolant bottle

High performance cutting oil spray

Operating instructions

A 10 Art. no.
108 010 A

Plastic tool case

Arbor holder Weldon

Allen keys 2.5 / 4 / 6

Safety belt

–

Coolant bottle

–

Operating instructions



Automatic EasyLock Quick-IN arbor for core drills with Weldon shank (3/4")

The EasyLock quick-in arbor enables a very quick tool change without additional tools. Can be operated with one hand.

Packing unit: individual carton



	Core drilling machine	Ø Core drills mm	No.	
EasyLock with MT 2 shank (Art. no. 108 312-1) and cooling bottle (Article no. 108 101)	RU25	10,0 - 60,0	108 312	1
EasyLock with MT 2 shank		10,0 - 60,0	108 312-1	1
EasyLock with MT 3 shank (Art. no. 108 313-1) and cooling bottle (Article no. 108 101)	RU40	10,0 - 60,0	108 313	1
EasyLock with MT 3 shank		10,0 - 60,0	108 313-1	1

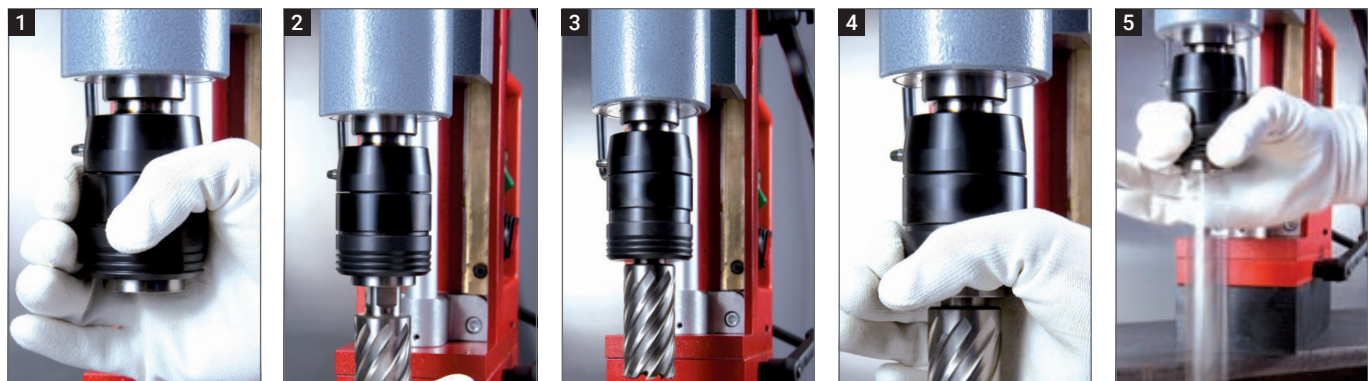

1. Push the ring spanner up until it sits tight.
2. Insert the core drill in the EasyLock. This locks in with a loud "click." The ring spanner snaps down.
3. The core drill is fixed securely in the EasyLock. The machine is now ready for operation.
4. To release the core drill, push the ring spanner up.
5. **Caution!** The core drill will fall out of the EasyLock.

Cooling bottle

	No.	
Cooling-spray bottle, 500 ml	108 101	1

Arbor holders for core drills with Weldon shank (3/4")

Packing unit: individual carton

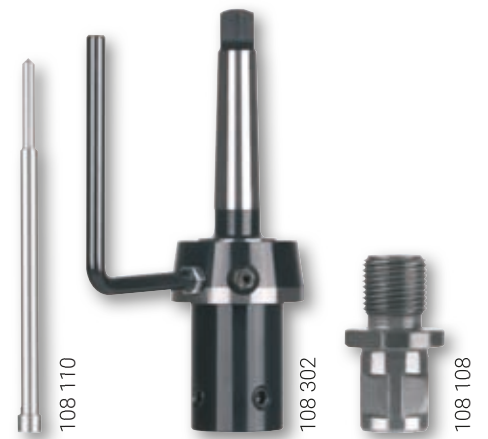

	Core drilling machine	Ø Core drills mm	No.	
Arbor holder with MT 2 shank (Art. no. 108 302-1) and cooling bottle (Art. no. 108 101)	RU 25	10,0 - 60,0	108 302	1
Arbor holder with MT 2 shank		10,0 - 60,0	108 302-1	1
Arbor holder with MT 3 shank (Art. no. 108 303-1) and cooling bottle (Art. no. 108 101)	RU 40	10,0 - 100,0	108 303	1
Arbor holder with MT 3 shank		10,0 - 100,0	108 303-1	1

Arbor holders for core drills with threaded retainer M18 x 6 P1,5

Packing unit: individual carton

	Core drilling machine	Ø Core drills mm	No.	
Arbor holder with MT 2 shank (No.108 102-1) including cooling bottle (Art. no.108 101) adapter (Art. no.108 108) and ejector pin (Art. no.108 110)	RU 25	12,0 - 80,0	108 102	1
Arbor holder with MT 2 shank		12,0 - 80,0	108 102-1	1
Arbor holder with MT 3 shank (No.108 103-1) including cooling bottle (Art. no.108 101) adapter (Art. no.108 108) and ejector pin (Art. no.108 110)	RU 40	12,0 - 80,0	108 103	1
Arbor holder with MT 3 shank		12,0 - 80,0	108 103-1	1



Arbor holders and quick-change inserts for core drilling machines

Packing unit: individual plastic pack



	Core drilling machine	No.	
Quick-acting holder with MT 2 shank and -5,0/+10,0 mm length compensation for thread taps	RU25	108 163	1
Quick-acting holder with MT 3 shank and +/-10,0 mm length compensation for thread taps	RU40	108 160	1
Morse taper no. 3 arbor holder for M 27 thread taps		108 161	1
Morse taper no. 3 arbor holder for M 30 thread taps		108 162	1

Quick-change insert „with“ safety coupling

For thread tap Ø-shank mm	Article no. „with“ safety coupling	
6,0	108 166	1
7,0	108 167	1
8,0	108 168	1
9,0	108 169	1
10,0	108 170	1
11,0	108 171	1
12,0	108 172	1
14,0	108 173	1
16,0	108 174	1
18,0	108 175	1

Quick-change insert „without“ safety coupling

For thread tap Ø-shank mm	Article no. „without“ safety coupling	
6,0	108 180	1
7,0	108 181	1
8,0	108 182	1
9,0	108 183	1
10,0	108 184	1
11,0	108 185	1
12,0	108 186	1
14,0	108 187	1
16,0	108 188	1
18,0	108 189	1

Overview of thread tap shaft diameters

Ø-shank mm	DIN 352	DIN 357 / DIN 376	DIN 371	UNC / UNF ≈ DIN 371	DIN 374	UNC / UNF ≈ DIN 376	DIN 5156	DIN 40433
6,0	M 4,5 - M 8	M 8	M 5 / M 6	Nr. 10/12 / 1/4"	MF 8		G 1/8"	PG 7
7,0	M 9 / M 10	M 9 / M 10	M 7		MF 10			
8,0	M 11	M 11	M 8	5/16"		7/16"		
9,0	M 12	M 12	M 9		MF 12	1/2"		PG 9
10,0			M 10	3/8"				
11,0	M 14	M 14			MF 14	9/16"	G 1/4"	PG 11
12,0	M 16	M 16			MF 16	5/8"	G 3/8"	PG 13,5
14,0	M 18	M 18			MF 18	3/4"		
16,0	M 20	M 20			MF 20		G 1/2"	
18,0	M 22 / M 24	M 22 / M 24			MF 22 / MF 24	7/8" / 1"		PG 21

General information:

1. Push the quick-release slot holder from below upwards into the slot until it is seated firmly.
2. Open the slot holder by pushing the locking ring upwards.
3. Insert the quick change unit into the quick-release slot holder. This is locked in with a loud „click“. The lock ring snaps down.
4. The machine threaded drill can be inserted easily into the quick-change unit.
5. The machine is now ready for use.

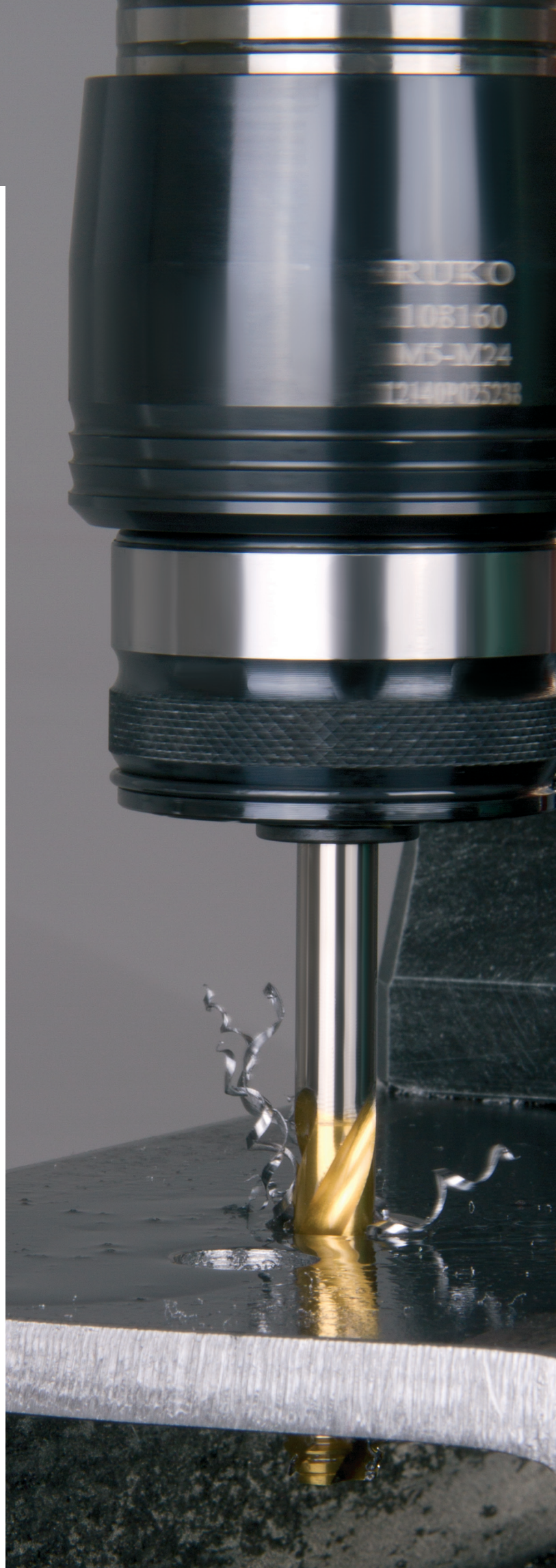
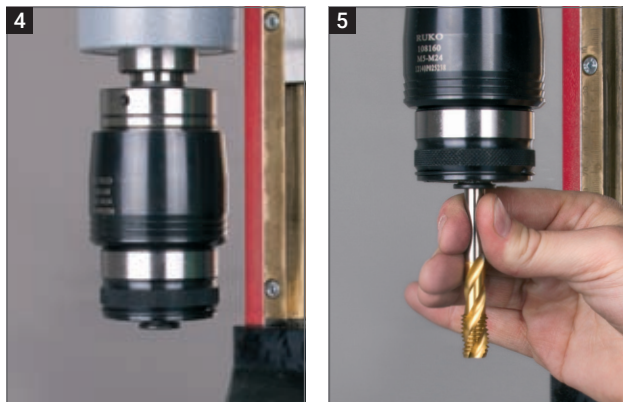
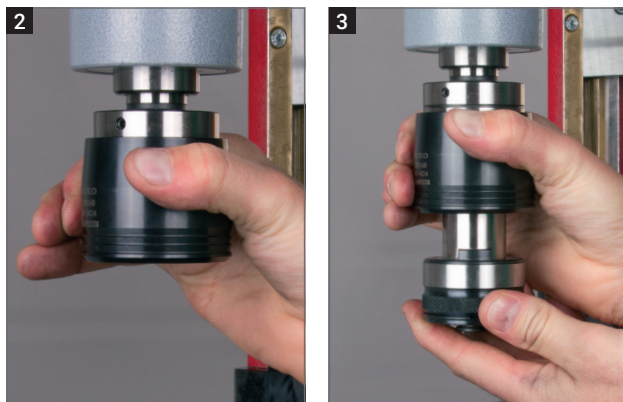
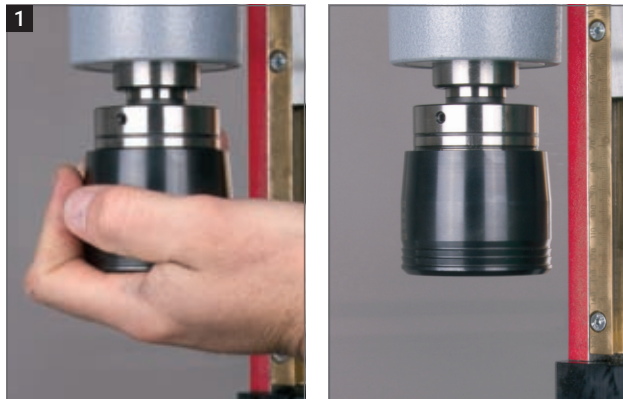



Adapter, drill chuck and accessories for core drilling machines

Packing unit: individual plastic pack



	Core drilling machine	No.	
Adapter with Weldon shank 3/4" for core drills with thread retainer M18 x 6 P1,5	A 10 RU25 RU40	108 108	1
Adapter with Weldon shank 3/4" for core drills with Quick IN-shank	A 10 RU25 RU40	108 126	1
Adapter with Quick IN-shank for core drills with thread retainer M18 x 6 P1,5	with Quick IN-retainer	108 111	1
Adapter with Quick IN-shank for core drills with Weldon shank 3/4"	with Quick IN-retainer	108 118	1
Adapter with Weldon shank 3/4" for core drills with Nitto shank	A 10 RU25 RU40	108 191	1

Drill chuck with thread retainer 1/2" UNF for clamp field Ø 1,0 - 13,0 mm	A 10	108 116	1
Drill chuck with B16 cone for clamp field Ø 3,0 - 16,0 mm	RU25 RU40	108 117	1
Adapter with Weldon shank 1/2" for drill chuck article no. 108 116	A 10	108 109	1
Spike cone with MT 2 shank for drill chuck article no. 108 117	RU25	108 120	1
Spike cone with MT 3 shank for drill chuck article no. 108 117	RU40	108 121	1
Sleeve to reduce MT 3 down to MT 2	RU40	108 125	1
Sleeve to reduce MT 3 down to MT 1	RU40	108 124	1



Adapter for thread taps with Weldon shank (3/4") in core drilling machines RU25 and RU40

Packing unit: individual plastic pack

Thread tap	For thread tap Ø-shank mm	Square mm	No.	
M 8	6,0		108 192	1
M 10	7,0	5,5	108 193	1
M 12	9,0	7,0	108 194	1
M 14	11,0	9,0	108 195	1
M 16	12,0	9,0	108 196	1
M 18	14,0	11,0	108 197	1
M 20	16,0	12,0	108 198	1
M 22 / 24	18,0	14,5	108 199	1
M 27	20,0	16,0	108 200	1
M 30	22,0	18,0	108 201	1



Magnetic chip lifter

The RUKO magnetic chip lifter attracts metal chips thanks to its strong magnet. Pulling back the magnet into its housing simply allows the chips to drop off again. Ideal for removing the chips on core drilling machines and difficult to reach areas.

Packing unit: individual plastic pack

	No.	
Magnetic chip lifter, 400,0 mm	108 202	1



High performance cutting oil spray

	No.	
High performance cutting oil spray, 300 ml 100% pure active substance - Free from propellant gas	101 012	1



Coolants and lubricants

RUKO high performance coolants and lubricants with outstanding cooling and anti-separation qualities. Increases tool life even with hard and brittle materials. High heat resistance ensures good lubrication and cooling, even at high temperatures. Good adhesion quality improves lubrication.

For all standard metal working processes, such as drilling, thread cutting, countersinking, deburring, sawing, turning, milling, grinding. Suitably aligned to our product range, you will find the coolants and lubricants in our main catalogue from page 289.

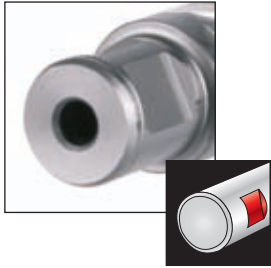

Solid drills with weldon shank (3/4")

For use in core drilling machines with morse taper retainer.

In connection with RUKO arbor holders no. 108 302 / 108 303, with RUKO EasyLock no. 108 312 / 108 313 or a weldon direct shank such as the RUKO core drilling machine RU25.

Handling

- Push Solid drill „Solid 3S“ into arbor and tighten hexagon socket screw firmly.
- Check proper seating of Solid drill „Solid 3S“ in arbor holder.
- With the EasyLock arbor, the Solid drill „Solid 3S“ gets automatically locked.
- Drill to full dimension straight away. No centring or pre-drilling required.
- The blade geometry of the Solid drill „Solid 3S“ permits rapid upward chip removal.
- Observe table of cutting speeds and employ appropriate cooling agent.



Core drills with weldon shank (3/4")

For use in core drilling machines with morse taper retainer.

In connection with RUKO arbor holders no. 108 302 / 108 303, with RUKO EasyLock no. 108 312 / 108 313 or a weldon direct shank such as the RUKO core drilling machine RU25.

Handling

- Insert Weldon shank ejector pin into core drill.
- Push core drill into arbor and tighten hexagon socket screw firmly.
- Check proper seating of core drill in arbor holder.
- With the EasyLock arbor, the core drill gets automatically locked.
- Drill to full dimension straight away. No centring or pre-drilling required.
- The blade geometry of the core drill permits rapid upward chip removal.
- The spring-loaded ejector pin facilitates removal of the cut-out.
- Observe table of cutting speeds and employ appropriate cooling agent.



Core drills HSS with Quick IN-shank

For use in core drilling machines in connection with Quick IN-adapter as the Fein KBM 32 Q.

Handling

- Insert ejector pin into core drill.
- Push core drill into Quick In-adapter.
- Drill to full dimension straight away. No centring or pre-drilling required.
- The blade geometry of the core drill permits rapid upward chip removal.
- The spring-loaded ejector pin facilitates removal of the cut-outs.
- Observe table of cutting speeds and employ appropriate cooling agent.



Core drills with threaded retainer

For use in core drilling machines with morse taper retainer. In connection with RUKO arbor holders no. 108 102 / 108 103, or a threaded retainer such as the Fein KBM 542 / KBM 65.

Handling

- Screw core drill into arbor holder.
- Drill to full dimension straight away. No centring or pre-drilling required.
- The blade geometry of the core drill permits rapid upward chip removal.
- The spring-loaded ejector pin facilitates removal of the cut-outs.
- Observe table of cutting speeds and employ appropriate cooling agent.



Range and applications overview:



Material	Surface	Drilling depth	Shank	Ejector pin	Core drilling machines	Ø mm	Article no.	Page
HSS		30,0 mm		108 304	A 10 RU25 RU40	12,0 - 60,0	108 212 - 108 260	22 - 23
HSSE Co 5		30,0 mm		108 304	A 10 RU25 RU40	12,0 - 60,0	108 212 E - 108 260 E	22 - 23
HSS	TiAlN	30,0 mm		108 304	A 10 RU25 RU40	12,0 - 60,0	108 212 F - 108 260 F	22 - 23
HSS		55,0 mm		108 305	RU25 RU40	12,0 - 60,0	108 512 - 108 560	24
HSSE Co 5		55,0 mm		108 305	RU25 RU40	12,0 - 60,0	108 512 E - 108 560 E	24
HSS	TiAlN	55,0 mm		108 305	RU25 RU40	12,0 - 60,0	108 512 F - 108 560 F	24
HSS		110,0 mm		108 2000	RU40	20,0 - 50,0	108 2020 - 108 2050	25
HSS	TiAlN	110,0 mm		108 2000	RU40	20,0 - 50,0	108 2020 F - 108 2050 F	25
HSSE Co 5		35,0 mm		108 306	A 10 RU25 RU40	12,0 - 60,0	108 912 E - 108 960 E	26
HSS		30,0 mm		-	A 10 RU25 RU40	10,0 - 15,0	108 1210 - 108 1215	27
TC		50,0 mm		108 305 108 701	A 10 RU25 RU40	12,0 - 50,0	108 712 - 108 750	29
TC	Tecrona	50,0 mm		108 305 108 701	A 10 RU25 RU40	12,0 - 50,0	108 712 C - 108 750 C	29
TC		50,0 mm		108 306 108 110	RU25 RU40	12,0 - 80,0	108 1112 - 108 1180	30 - 31
TC	Tecrona	50,0 mm		108 306 108 110	RU25 RU40	12,0 - 80,0	108 1112 C - 108 1180 C	30 - 31
TC		50,0 mm		108 110	RU25 RU40	12,0 - 80,0	108 012 - 108 080	32 - 33
TC	Tecrona	50,0 mm		108 110	RU25 RU40	12,0 - 80,0	108 012 C - 108 080 C	32 - 33
TC		30,0 mm		108 1510	A 10 RU25 RU40	19,0 - 36,0	108 1519 - 108 1536	34
TC	Tecrona	30,0 mm		108 1510	A 10 RU25 RU40	19,0 - 36,0	108 1519 C - 108 1536 C	34



Steel (N/mm ²) < 900	Steel (N/mm ²) < 1100	Steel (N/mm ²) < 1300	Stainless steel	Aluminium	Brass	Bronze	Plastics	Cast iron	Titanium alloyed
■				■	■	□	■	□	
■	■	□	■	■	■	□	■	□	
■	■	□	■	■	■	□	■	□	
■				■	■	□	■	□	
■	■	□	■	■	■	□	■	□	
■	■	□	■	■	■	□	■	□	
■				■	■	□	■	□	
■	■	□	■	■	■	□	■	□	
■	■	□	■	■	■	□	■	□	
■				■	■	□	■	□	
■	■	□	■	■	■	□	■	■	□
■	■	■	■	■	■	■	■	■	■
■	■	□	■	■	■	□	■	■	□
■	■	■	■	■	■	■	■	■	■
■	■	□	■	■	■	□	■	■	□
■	■	■	■	■	■	■	■	■	■
	■	□							
	■	■							

■ Main application

□ Other application



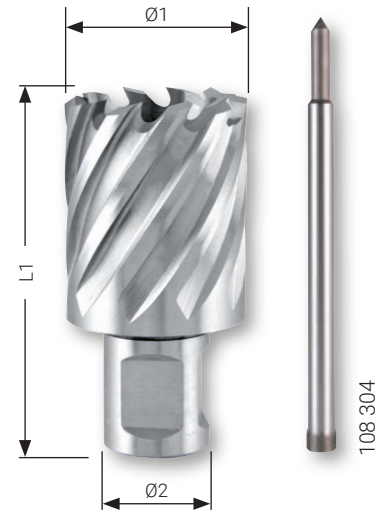

Core drills HSS and HSSE-Co 5 with weldon shank (3/4"), cutting depth 30,0 mm

Ejector pin: Article no. 108 304 (Ø 6,35 x 77,0 mm)

Packing unit: in plastic tubes of 1

Steel (N/mm2) < 900	■	■	■	Brass	■	■	■
Steel (N/mm2) < 1100		■	■	Bronze	□	□	□
Steel (N/mm2) < 1300		□	□	Plastics	■	■	■
Rust-resistant steel		■	■	Cast iron	□	□	□
Aluminium	■	■	■	Titanium alloyed			

Ø1 mm	Ø2 mm	L1 mm	Cutting depth mm	HSS	HSSE Co 5	HSS TITAN	
12,0	19,0	63,0	30,0	108 212	108 212 E	108 212 F	1
13,0	19,0	63,0	30,0	108 213	108 213 E	108 213 F	1
14,0	19,0	63,0	30,0	108 214	108 214 E	108 214 F	1
15,0	19,0	63,0	30,0	108 215	108 215 E	108 215 F	1
16,0	19,0	63,0	30,0	108 216	108 216 E	108 216 F	1
17,0	19,0	63,0	30,0	108 217	108 217 E	108 217 F	1
18,0	19,0	63,0	30,0	108 218	108 218 E	108 218 F	1
19,0	19,0	63,0	30,0	108 219	108 219 E	108 219 F	1
20,0	19,0	63,0	30,0	108 220	108 220 E	108 220 F	1
21,0	19,0	63,0	30,0	108 221	108 221 E	108 221 F	1
22,0	19,0	63,0	30,0	108 222	108 222 E	108 222 F	1
23,0	19,0	63,0	30,0	108 223	108 223 E	108 223 F	1
24,0	19,0	63,0	30,0	108 224	108 224 E	108 224 F	1
25,0	19,0	63,0	30,0	108 225	108 225 E	108 225 F	1
26,0	19,0	63,0	30,0	108 226	108 226 E	108 226 F	1
27,0	19,0	63,0	30,0	108 227	108 227 E	108 227 F	1
28,0	19,0	63,0	30,0	108 228	108 228 E	108 228 F	1
29,0	19,0	63,0	30,0	108 229	108 229 E	108 229 F	1
30,0	19,0	63,0	30,0	108 230	108 230 E	108 230 F	1
31,0	19,0	63,0	30,0	108 231	108 231 E	108 231 F	1
32,0	19,0	63,0	30,0	108 232	108 232 E	108 232 F	1
33,0	19,0	63,0	30,0	108 233	108 233 E	108 233 F	1
34,0	19,0	63,0	30,0	108 234	108 234 E	108 234 F	1
35,0	19,0	63,0	30,0	108 235	108 235 E	108 235 F	1
36,0	19,0	63,0	30,0	108 236	108 236 E	108 236 F	1
37,0	19,0	63,0	30,0	108 237	108 237 E	108 237 F	1
38,0	19,0	63,0	30,0	108 238	108 238 E	108 238 F	1
39,0	19,0	63,0	30,0	108 239	108 239 E	108 239 F	1
40,0	19,0	63,0	30,0	108 240	108 240 E	108 240 F	1
41,0	19,0	63,0	30,0	108 241	108 241 E	108 241 F	1
42,0	19,0	63,0	30,0	108 242	108 242 E	108 242 F	1
43,0	19,0	63,0	30,0	108 243	108 243 E	108 243 F	1
44,0	19,0	63,0	30,0	108 244	108 244 E	108 244 F	1
45,0	19,0	63,0	30,0	108 245	108 245 E	108 245 F	1
46,0	19,0	63,0	30,0	108 246	108 246 E	108 246 F	1
47,0	19,0	63,0	30,0	108 247	108 247 E	108 247 F	1
48,0	19,0	63,0	30,0	108 248	108 248 E	108 248 F	1
49,0	19,0	63,0	30,0	108 249	108 249 E	108 249 F	1
50,0	19,0	63,0	30,0	108 250	108 250 E	108 250 F	1
51,0	19,0	63,0	30,0	108 251	108 251 E	108 251 F	1
52,0	19,0	63,0	30,0	108 252	108 252 E	108 252 F	1
53,0	19,0	63,0	30,0	108 253	108 253 E	108 253 F	1
54,0	19,0	63,0	30,0	108 254	108 254 E	108 254 F	1
55,0	19,0	63,0	30,0	108 255	108 255 E	108 255 F	1
56,0	19,0	63,0	30,0	108 256	108 256 E	108 256 F	1
57,0	19,0	63,0	30,0	108 257	108 257 E	108 257 F	1
58,0	19,0	63,0	30,0	108 258	108 258 E	108 258 F	1
59,0	19,0	63,0	30,0	108 259	108 259 E	108 259 F	1
60,0	19,0	63,0	30,0	108 260	108 260 E	108 260 F	1



Set of core drills HSS and HSSE-Co 5 with weldon shank (3/4"), cutting depth 30,0 mm in plastic case

Description	HSS	HSSE Co 5
10-piece set of core drills with weldon shank (3/4") 8 core drills with weldon shank (3/4") Ø 12,0 mm - 14,0 mm - 16,0 mm - 18,0 mm - 20,0 mm - 22,0 mm - 24,0 mm - 26,0 mm + 1 cutting paste 50 g, article no. 101 021 + 1 ejector pin Ø 6,35 mm x 77,0 mm for cutting depth 30,0 mm article no. 108 304	108 810	108 810 E
10-piece set of core drills with weldon shank (3/4") 8 core drills with weldon shank (3/4") Ø 2 x 14,0 mm - 2 x 16,0 mm - 2 x 18,0 mm - 1 x 20,0 mm - 1 x 22,0 mm + 1 cutting paste 50 g, article no. 101 021 + 1 ejector pin Ø 6,35 mm x 77,0 mm for cutting depth 30,0 mm article no. 108 304	108 813	—



Set of core drills HSS and HSSE-Co 5 with weldon shank (3/4"), cutting depth 30,0 mm in steel case

Description	HSS	HSSE Co 5	HSS TiAIN
7-piece set of core drills with weldon shank (3/4") 6 core drills with weldon shank (3/4") Ø 12,0 mm - 14,0 mm - 16,0 mm - 18,0 mm - 20,0 mm - 22,0 mm + 1 ejector pin Ø 6,35 mm x 77,0 mm for cutting depth 30,0 mm article no. 108 304	108 820	—	108 820 F
7-piece set of core drills with weldon shank (3/4") 6 core drills with weldon shank (3/4") Ø 2 x 14,0 mm - 2 x 18,0 mm - 2 x 22,0 mm + 1 ejector pin Ø 6,35 mm x 77,0 mm for cutting depth 30,0 mm article no. 108 304	108 840	108 840 E	108 840 F



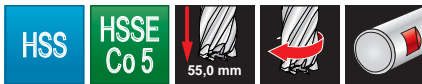

Core drills HSS and HSSE-Co 5 with weldon shank (3/4"), cutting depth 55,0 mm

Ejector pin: Article no. 108 305 (Ø 6,35 x 102,0 mm)

Packing unit: in plastic tubes of 1

Steel (N/mm2) < 900	■	■	■	Brass	■	■	■
Steel (N/mm2) < 1100		■	■	Bronze	□	□	□
Steel (N/mm2) < 1300		□	□	Plastics	■	■	■
Rust-resistant steel		■	■	Cast iron	□	□	□
Aluminium	■	■	■	Titanium alloyed			

Ø1 mm	Ø2 mm	L1 mm	Cutting depth mm	HSS	HSSE Co 5	HSS TITAN	
12,0	19,0	88,0	55,0	108 512	108 512 E	108 512 F	1
13,0	19,0	88,0	55,0	108 513	108 513 E	108 513 F	1
14,0	19,0	88,0	55,0	108 514	108 514 E	108 514 F	1
15,0	19,0	88,0	55,0	108 515	108 515 E	108 515 F	1
16,0	19,0	88,0	55,0	108 516	108 516 E	108 516 F	1
17,0	19,0	88,0	55,0	108 517	108 517 E	108 517 F	1
18,0	19,0	88,0	55,0	108 518	108 518 E	108 518 F	1
19,0	19,0	88,0	55,0	108 519	108 519 E	108 519 F	1
20,0	19,0	88,0	55,0	108 520	108 520 E	108 520 F	1
21,0	19,0	88,0	55,0	108 521	108 521 E	108 521 F	1
22,0	19,0	88,0	55,0	108 522	108 522 E	108 522 F	1
23,0	19,0	88,0	55,0	108 523	108 523 E	108 523 F	1
24,0	19,0	88,0	55,0	108 524	108 524 E	108 524 F	1
25,0	19,0	88,0	55,0	108 525	108 525 E	108 525 F	1
26,0	19,0	88,0	55,0	108 526	108 526 E	108 526 F	1
27,0	19,0	88,0	55,0	108 527	108 527 E	108 527 F	1
28,0	19,0	88,0	55,0	108 528	108 528 E	108 528 F	1
29,0	19,0	88,0	55,0	108 529	108 529 E	108 529 F	1
30,0	19,0	88,0	55,0	108 530	108 530 E	108 530 F	1
31,0	19,0	88,0	55,0	108 531	108 531 E	108 531 F	1
32,0	19,0	88,0	55,0	108 532	108 532 E	108 532 F	1
33,0	19,0	88,0	55,0	108 533	108 533 E	108 533 F	1
34,0	19,0	88,0	55,0	108 534	108 534 E	108 534 F	1
35,0	19,0	88,0	55,0	108 535	108 535 E	108 535 F	1
36,0	19,0	88,0	55,0	108 536	108 536 E	108 536 F	1
37,0	19,0	88,0	55,0	108 537	108 537 E	108 537 F	1
38,0	19,0	88,0	55,0	108 538	108 538 E	108 538 F	1
39,0	19,0	88,0	55,0	108 539	108 539 E	108 539 F	1
40,0	19,0	88,0	55,0	108 540	108 540 E	108 540 F	1
41,0	19,0	88,0	55,0	108 541	108 541 E	108 541 F	1
42,0	19,0	88,0	55,0	108 542	108 542 E	108 542 F	1
43,0	19,0	88,0	55,0	108 543	108 543 E	108 543 F	1
44,0	19,0	88,0	55,0	108 544	108 544 E	108 544 F	1
45,0	19,0	88,0	55,0	108 545	108 545 E	108 545 F	1
46,0	19,0	88,0	55,0	108 546	108 546 E	108 546 F	1
47,0	19,0	88,0	55,0	108 547	108 547 E	108 547 F	1
48,0	19,0	88,0	55,0	108 548	108 548 E	108 548 F	1
49,0	19,0	88,0	55,0	108 549	108 549 E	108 549 F	1
50,0	19,0	88,0	55,0	108 550	108 550 E	108 550 F	1
51,0	19,0	88,0	55,0	108 551	108 551 E	108 551 F	1
52,0	19,0	88,0	55,0	108 552	108 552 E	108 552 F	1
53,0	19,0	88,0	55,0	108 553	108 553 E	108 553 F	1
54,0	19,0	88,0	55,0	108 554	108 554 E	108 554 F	1
55,0	19,0	88,0	55,0	108 555	108 555 E	108 555 F	1
56,0	19,0	88,0	55,0	108 556	108 556 E	108 556 F	1
57,0	19,0	88,0	55,0	108 557	108 557 E	108 557 F	1
58,0	19,0	88,0	55,0	108 558	108 558 E	108 558 F	1
59,0	19,0	88,0	55,0	108 559	108 559 E	108 559 F	1
60,0	19,0	88,0	55,0	108 560	108 560 E	108 560 F	1

HSS**RU40**

Core drills HSS with weldon shank (3/4"), cutting depth 110,0 mm

Ejector pin: Article no. 108 2000 (Ø 8,0 x 155,0 mm)

Packing unit: in plastic tubes of 1



Move core drill out of the hole, remove the chips in the borehole.
Repeat this procedure several times.
Reduces the risk of breakage and increases the service life of the core drill.



Steel (N/mm ²) < 900	■	■
Steel (N/mm ²) < 1100		■
Steel (N/mm ²) < 1300		□
Rust-resistant steel		■
Aluminium	■	■

Brass	■	■
Bronze	□	□
Plastics	■	■
Cast iron	□	□
Titanium alloyed		

Ø1 mm	Ø2 mm	L1 mm	Cutting depth mm			
20,0	19,0	145,0	110,0	108 2020	108 2020 F	1
21,0	19,0	145,0	110,0	108 2021	108 2021 F	1
22,0	19,0	145,0	110,0	108 2022	108 2022 F	1
24,0	19,0	145,0	110,0	108 2024	108 2024 F	1
25,0	19,0	145,0	110,0	108 2025	108 2025 F	1
26,0	19,0	145,0	110,0	108 2026	108 2026 F	1
28,0	19,0	145,0	110,0	108 2028	108 2028 F	1
30,0	19,0	145,0	110,0	108 2030	108 2030 F	1
32,0	19,0	145,0	110,0	108 2032	108 2032 F	1
33,0	19,0	145,0	110,0	108 2033	108 2033 F	1
34,0	19,0	145,0	110,0	108 2034	108 2034 F	1
35,0	19,0	145,0	110,0	108 2035	108 2035 F	1
36,0	19,0	145,0	110,0	108 2036	108 2036 F	1
38,0	19,0	145,0	110,0	108 2038	108 2038 F	1
40,0	19,0	145,0	110,0	108 2040	108 2040 F	1
41,0	19,0	145,0	110,0	108 2041	108 2041 F	1
42,0	19,0	145,0	110,0	108 2042	108 2042 F	1
45,0	19,0	145,0	110,0	108 2045	108 2045 F	1
50,0	19,0	145,0	110,0	108 2050	108 2050 F	1



■ Main application

□ Other application





HSSE
Co 5



RU40 | RU25 | A 10

Core drills HSSE-Co 5 with Quick IN-shank, cutting depth 35,0 mm

Ejector pin: Article no. 108 306 (Ø 6,35 x 87,0 mm)
Machine no.: with Quick IN-adapter

Packing unit: in plastic tubes of 1

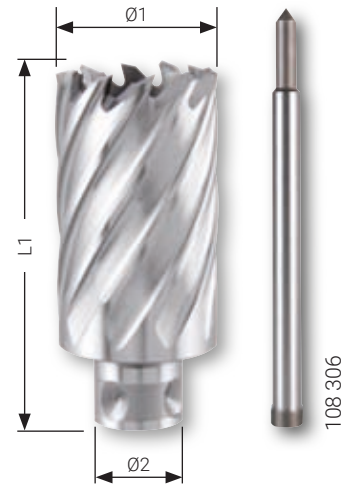

Steel (N/mm2) < 900	■	Brass	■
Steel (N/mm2) < 1100	■	Bronze	□
Steel (N/mm2) < 1300	□	Plastics	■
Rust-resistant steel	■	Cast iron	□
Aluminium	■	Titanium alloyed	□

Ø1 mm	Ø2 mm	L1 mm	Cutting depth mm	HSSE Co 5		
12,0	18,0	77,0	35,0	108 912 E		1
13,0	18,0	77,0	35,0	108 913 E		1
14,0	18,0	77,0	35,0	108 914 E		1
15,0	18,0	77,0	35,0	108 915 E		1
16,0	18,0	77,0	35,0	108 916 E		1
17,0	18,0	77,0	35,0	108 917 E		1
18,0	18,0	77,0	35,0	108 918 E		1
19,0	18,0	77,0	35,0	108 919 E		1
20,0	18,0	77,0	35,0	108 920 E		1
21,0	18,0	77,0	35,0	108 921 E		1
22,0	18,0	77,0	35,0	108 922 E		1
23,0	18,0	77,0	35,0	108 923 E		1
24,0	18,0	77,0	35,0	108 924 E		1
25,0	18,0	77,0	35,0	108 925 E		1
26,0	18,0	77,0	35,0	108 926 E		1
27,0	18,0	77,0	35,0	108 927 E		1
28,0	18,0	77,0	35,0	108 928 E		1
29,0	18,0	77,0	35,0	108 929 E		1
30,0	18,0	77,0	35,0	108 930 E		1
32,0	18,0	77,0	35,0	108 932 E		1
35,0	18,0	77,0	35,0	108 935 E		1
36,0	18,0	77,0	35,0	108 936 E		1
40,0	18,0	77,0	35,0	108 940 E		1
45,0	18,0	77,0	35,0	108 945 E		1
50,0	18,0	77,0	35,0	108 950 E		1
55,0	18,0	77,0	35,0	108 955 E		1
60,0	18,0	77,0	35,0	108 960 E		1

Set of core drills HSSE-Co 5 with Quick IN-shank, in plastic case

10-piece set of core drills HSSE-Co 5 with Quick IN-shank 8 core drills HSSE-Co 5 Ø 12,0 mm - 14,0 mm - 16,0 mm - 18,0 mm 20,0 mm - 22,0 mm - 24,0 mm - 26,0 mm + 1 cutting paste 50 g, article no. 101 021 + 1 ejector pin Ø 6,35 x 87,0 mm for cutting depth 35,0 mm, article no. 108 306	108 811 E





Solid drills „Solid 3S“ with weldon shank (3/4") and 3 cutting edges, cutting depth 30,0 mm

The spiral-grooved geometry with 3 cutting edges ensures extremely high stability of the "Solid 3S" solid drill, thus preventing the risk of breakage of the cutting edges by overloading or jamming of the chips. Thanks to the high stability, the service life of the "Solid 3S" is considerably increased. This reduces the costs of use. The "Solid 3S" enables drilling to full dimension without centring or pre-drilling. The "Solid 3S" can be ground more simply than core drills of the same diameter.



Packing unit: in plastic tubes of 1



Reduces the risk of breakage compared to core drills up to Ø 15.0 mm. Cooling required.

Steel (N/mm ²) < 900	■
Steel (N/mm ²) < 1100	
Steel (N/mm ²) < 1300	
Rust-resistant steel	
Aluminium	■

Brass	■
Bronze	□
Plastics	■
Cast iron	□
Titanium alloyed	

Ø1 mm	Ø2 mm	L1 mm	Cutting depth mm	HSS		
10,0	19,0	64,0	30,0	108 1210		1
11,0	19,0	64,0	30,0	108 1211		1
12,0	19,0	64,0	30,0	108 1212		1
13,0	19,0	64,0	30,0	108 1213		1
14,0	19,0	64,0	30,0	108 1214		1
15,0	19,0	64,0	30,0	108 1215		1

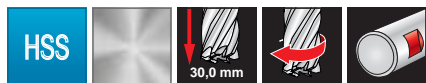

Solid drills „Solid 3S“ with weldon shank (3/4") and 3 cutting edges in steel case

Description	
6- piece set of solid drills „Solid 3S“ HSS Ø 10,0 mm - 11,0 mm - 12,0 mm - 13,0 mm - 14,0 mm - 15,0 mm	108 830





Product Information

The RUKO core drills with Tecrona coating and hard metal cutting edges can be universally used in non-hardened steels and super alloys (materials with very high alloy percentages of Al,Ti, nickel like inconel, hastelloy, Inox, etc.).

Technical data

Surface:	blue-grey
Hardness:	4200 HV
Thickness:	1µm - 7µm
Coefficient of friction:	0.35

Advantages of the Tecrona coating

The Tecrona coating is the ideal coating for all drilling works that stress the tool extremely. It adheres very well to the tool, where by the wear-resistant coating increases the surface hardness to approximately 4200 HV. The coefficient of friction is extremely low in this coating, thereby increasing the service life with low wear.

Applications:
Particularly for rail tracks, Hardox / Weldox steel, steel, cast iron, high-alloyed chromium steel such as stainless and acid-resistant steel.

Comparison of hardness

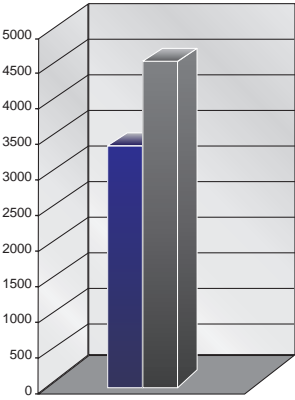

Comparison of coefficients of friction

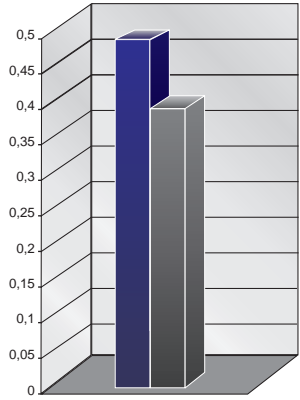

Temperature resistance

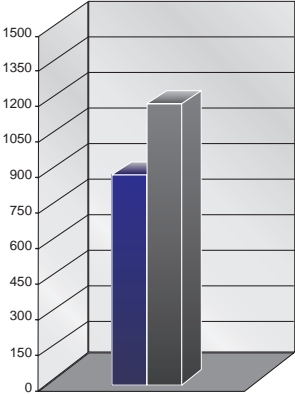

■ TiAlN
■ Tecrona





Core drills with tungsten-carbide cutting edges and weldon shank (3/4", cutting depth 50,0 mm)

Suitable for Hardox / Weldox 400 steel

Ejector pin:

Ø 12,0 mm up to Ø 17,0, Article no. 108 305 (Ø 6,35 x 102,0 mm)

Ø 18,0 mm up to Ø 50,0, Article no. 108 701 (Ø 8,0 x 112,0 mm)

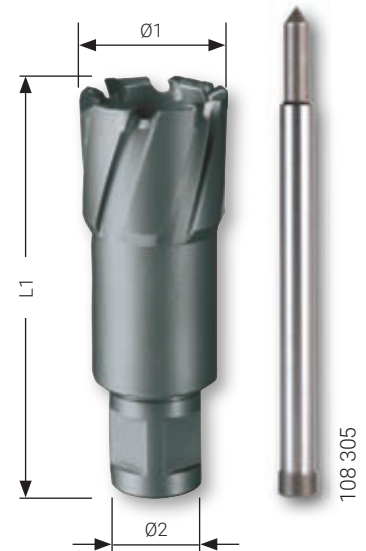

Packing unit: individual plastic pack

Steel (N/mm ²) < 900	■	■
Steel (N/mm ²) < 1100	■	■
Steel (N/mm ²) < 1300	□	■
Rust-resistant steel	■	■
Aluminium	■	■

Brass	■	■
Bronze	□	■
Plastics	■	■
Cast iron	■	■
Titanium alloyed	□	■

Ø1 mm	Ø2 mm	L1 mm	Cutting depth mm	TC	TC	
12,0	19,0	84,0	50,0	108 712	108 712 C	1
13,0	19,0	84,0	50,0	108 713	108 713 C	1
14,0	19,0	84,0	50,0	108 714	108 714 C	1
15,0	19,0	84,0	50,0	108 715	108 715 C	1
16,0	19,0	84,0	50,0	108 716	108 716 C	1
17,0	19,0	84,0	50,0	108 717	108 717 C	1
18,0	19,0	84,0	50,0	108 718	108 718 C	1
19,0	19,0	84,0	50,0	108 719	108 719 C	1
20,0	19,0	84,0	50,0	108 720	108 720 C	1
21,0	19,0	84,0	50,0	108 721	108 721 C	1
22,0	19,0	84,0	50,0	108 722	108 722 C	1
23,0	19,0	84,0	50,0	108 723	108 723 C	1
24,0	19,0	84,0	50,0	108 724	108 724 C	1
25,0	19,0	84,0	50,0	108 725	108 725 C	1
26,0	19,0	84,0	50,0	108 726	108 726 C	1
27,0	19,0	84,0	50,0	108 727	108 727 C	1
28,0	19,0	84,0	50,0	108 728	108 728 C	1
29,0	19,0	84,0	50,0	108 729	108 729 C	1
30,0	19,0	84,0	50,0	108 730	108 730 C	1
31,0	19,0	84,0	50,0	108 731	108 731 C	1
32,0	19,0	84,0	50,0	108 732	108 732 C	1
33,0	19,0	84,0	50,0	108 733	108 733 C	1
34,0	19,0	84,0	50,0	108 734	108 734 C	1
35,0	19,0	84,0	50,0	108 735	108 735 C	1
36,0	19,0	84,0	50,0	108 736	108 736 C	1
37,0	19,0	84,0	50,0	108 737	108 737 C	1
38,0	19,0	84,0	50,0	108 738	108 738 C	1
39,0	19,0	84,0	50,0	108 739	108 739 C	1
40,0	19,0	84,0	50,0	108 740	108 740 C	1
41,0	19,0	84,0	50,0	108 741	108 741 C	1
42,0	19,0	84,0	50,0	108 742	108 742 C	1
43,0	19,0	84,0	50,0	108 743	108 743 C	1
44,0	19,0	84,0	50,0	108 744	108 744 C	1
45,0	19,0	84,0	50,0	108 745	108 745 C	1
46,0	19,0	84,0	50,0	108 746	108 746 C	1
47,0	19,0	84,0	50,0	108 747	108 747 C	1
48,0	19,0	84,0	50,0	108 748	108 748 C	1
49,0	19,0	84,0	50,0	108 749	108 749 C	1
50,0	19,0	84,0	50,0	108 750	108 750 C	1

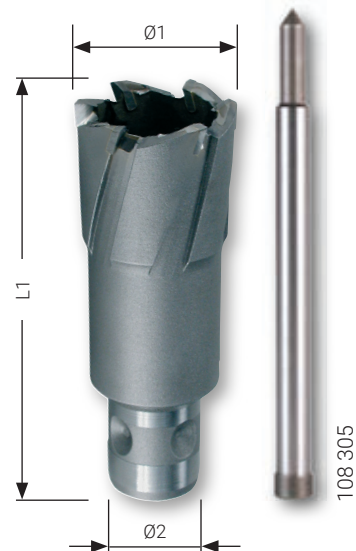

Core drills with tungsten-carbide and Quick IN-shank, cutting depth 50,0 mm

Ø 12,0 mm up to Ø 32,0 mm with fixed shank.
 Ø 33,0 mm up to Ø 80,0 mm including Quick IN-adaptor No. 108 111.

Machine no.: with Quick IN-adaptor
 Ejector pin: Ø 12,0 mm up to Ø 32,0 mm, article no. 108 305 (Ø 6,35 x 102,0 mm)
 Ø 33,0 mm up to Ø 80,0 mm, article no. 108 110 (Ø 6,35 x 123,0 mm)

Packing unit: individual plastic pack

Steel (N/mm ²) < 900	<input checked="" type="checkbox"/> <input checked="" type="checkbox"/>
Steel (N/mm ²) < 1100	<input checked="" type="checkbox"/> <input checked="" type="checkbox"/>
Steel (N/mm ²) < 1300	<input type="checkbox"/> <input checked="" type="checkbox"/>
Rust-resistant steel	<input checked="" type="checkbox"/> <input checked="" type="checkbox"/>
Aluminium	<input checked="" type="checkbox"/> <input checked="" type="checkbox"/>

Brass	<input checked="" type="checkbox"/> <input checked="" type="checkbox"/>
Bronze	<input type="checkbox"/> <input checked="" type="checkbox"/>
Plastics	<input checked="" type="checkbox"/> <input checked="" type="checkbox"/>
Cast iron	<input checked="" type="checkbox"/> <input checked="" type="checkbox"/>
Titanium alloyed	<input type="checkbox"/> <input checked="" type="checkbox"/>

Ø1 mm	Ø2 mm	L1 mm	Cutting depth mm	TC	TC	
12,0	18,0	83,0	50,0	108 1112	108 1112 C	1
13,0	18,0	83,0	50,0	108 1113	108 1113 C	1
14,0	18,0	83,0	50,0	108 1114	108 1114 C	1
15,0	18,0	83,0	50,0	108 1115	108 1115 C	1
16,0	18,0	83,0	50,0	108 1116	108 1116 C	1
17,0	18,0	83,0	50,0	108 1117	108 1117 C	1
18,0	18,0	83,0	50,0	108 1118	108 1118 C	1
19,0	18,0	83,0	50,0	108 1119	108 1119 C	1
20,0	18,0	83,0	50,0	108 1120	108 1120 C	1
21,0	18,0	83,0	50,0	108 1121	108 1121 C	1
22,0	18,0	83,0	50,0	108 1122	108 1122 C	1
23,0	18,0	83,0	50,0	108 1123	108 1123 C	1
24,0	18,0	83,0	50,0	108 1124	108 1124 C	1
25,0	18,0	83,0	50,0	108 1125	108 1125 C	1
26,0	18,0	83,0	50,0	108 1126	108 1126 C	1
27,0	18,0	83,0	50,0	108 1127	108 1127 C	1
28,0	18,0	83,0	50,0	108 1128	108 1128 C	1
29,0	18,0	83,0	50,0	108 1129	108 1129 C	1
30,0	18,0	83,0	50,0	108 1130	108 1130 C	1
31,0	18,0	83,0	50,0	108 1131	108 1131 C	1
32,0	18,0	83,0	50,0	108 1132	108 1132 C	1
33,0	18,0	112,0	50,0	108 1133	108 1133 C	1
34,0	18,0	112,0	50,0	108 1134	108 1134 C	1
35,0	18,0	112,0	50,0	108 1135	108 1135 C	1
36,0	18,0	112,0	50,0	108 1136	108 1136 C	1
37,0	18,0	112,0	50,0	108 1137	108 1137 C	1
38,0	18,0	112,0	50,0	108 1138	108 1138 C	1
39,0	18,0	112,0	50,0	108 1139	108 1139 C	1
40,0	18,0	112,0	50,0	108 1140	108 1140 C	1
41,0	18,0	112,0	50,0	108 1141	108 1141 C	1
42,0	18,0	112,0	50,0	108 1142	108 1142 C	1
43,0	18,0	112,0	50,0	108 1143	108 1143 C	1
44,0	18,0	112,0	50,0	108 1144	108 1144 C	1
45,0	18,0	112,0	50,0	108 1145	108 1145 C	1
46,0	18,0	112,0	50,0	108 1146	108 1146 C	1
47,0	18,0	112,0	50,0	108 1147	108 1147 C	1
48,0	18,0	112,0	50,0	108 1148	108 1148 C	1
49,0	18,0	112,0	50,0	108 1149	108 1149 C	1
50,0	18,0	112,0	50,0	108 1150	108 1150 C	1



Ø1 mm	Ø2 mm	L1 mm	Cutting depth mm	TC	TC Tecrona	
51,0	18,0	112,0	50,0	108 1151	108 1151 C	1
52,0	18,0	112,0	50,0	108 1152	108 1152 C	1
53,0	18,0	112,0	50,0	108 1153	108 1153 C	1
54,0	18,0	112,0	50,0	108 1154	108 1154 C	1
55,0	18,0	112,0	50,0	108 1155	108 1155 C	1
60,0	18,0	112,0	50,0	108 1160	108 1160 C	1
61,0	18,0	112,0	50,0	108 1161	108 1161 C	1
63,0	18,0	112,0	50,0	108 1163	108 1163 C	1
65,0	18,0	112,0	50,0	108 1165	108 1165 C	1
68,0	18,0	112,0	50,0	108 1168	108 1168 C	1
70,0	18,0	112,0	50,0	108 1170	108 1170 C	1
71,0	18,0	112,0	50,0	108 1171	108 1171 C	1
75,0	18,0	112,0	50,0	108 1175	108 1175 C	1
80,0	18,0	112,0	50,0	108 1180	108 1180 C	1



Set of core drills with tungsten-carbide cutting edges and Quick IN-shank, in plastic case

	TC
10-piece set of core drills with tungsten-carbide cutting edges 8 core drills with tungsten-carbide cutting edges and Quick IN-shank Ø 12,0 mm - 14,0 mm - 16,0 mm - 18,0 mm 20,0 mm - 22,0 mm - 24,0 mm - 26,0 mm + 1 cutting paste 50 g, article no. 101 021 + 1 ejector pin Ø 6,35 x 102,0 mm for cutting depth 50,0 mm article no. 108 305	108 822



i Coolants and lubricants

RUKO high performance coolants and lubricants with outstanding cooling and anti-separation qualities. Increases tool life even with hard and brittle materials. High heat resistance ensures good lubrication and cooling, even at high temperatures. Good adhesion quality improves lubrication.

For all standard metal working processes, such as drilling, thread cutting, countersinking, deburring, sawing, turning, milling, grinding. Suitably aligned to our product range, you will find the coolants and lubricants in our main catalogue from page 289.





TC



RU40 RU25

Core drills with tungsten-carbide cutting edges and threaded retainer, cutting depth 50,0 mm

Ejector pin: Article no. 108 110 (Ø 6,35 x 123,0 mm)
Adapter: thread M18 x 6 P1,5

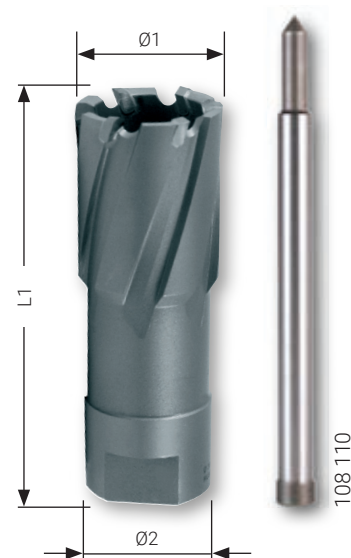

Packing unit: individual plastic pack

Steel (N/mm2) < 900	<input checked="" type="checkbox"/> <input checked="" type="checkbox"/>
Steel (N/mm2) < 1100	<input checked="" type="checkbox"/> <input checked="" type="checkbox"/>
Steel (N/mm2) < 1300	<input type="checkbox"/> <input checked="" type="checkbox"/>
Rust-resistant steel	<input checked="" type="checkbox"/> <input checked="" type="checkbox"/>
Aluminium	<input checked="" type="checkbox"/> <input checked="" type="checkbox"/>

Brass	<input checked="" type="checkbox"/> <input checked="" type="checkbox"/>
Bronze	<input type="checkbox"/> <input checked="" type="checkbox"/>
Plastics	<input checked="" type="checkbox"/> <input checked="" type="checkbox"/>
Cast iron	<input checked="" type="checkbox"/> <input checked="" type="checkbox"/>
Titanium alloyed	<input type="checkbox"/> <input checked="" type="checkbox"/>

Ø1 mm	Ø2 mm	L1 mm	Cutting depth mm	TC	TC	
12,0	MT 2 / 3	84,0	50,0	108 012	108 012 C	1
13,0	MT 2 / 3	84,0	50,0	108 013	108 013 C	1
14,0	MT 2 / 3	84,0	50,0	108 014	108 014 C	1
15,0	MT 2 / 3	84,0	50,0	108 015	108 015 C	1
16,0	MT 2 / 3	84,0	50,0	108 016	108 016 C	1
17,0	MT 2 / 3	84,0	50,0	108 017	108 017 C	1
18,0	MT 2 / 3	84,0	50,0	108 018	108 018 C	1
19,0	MT 2 / 3	84,0	50,0	108 019	108 019 C	1
20,0	MT 2 / 3	84,0	50,0	108 020	108 020 C	1
21,0	MT 2 / 3	84,0	50,0	108 021	108 021 C	1
22,0	MT 2 / 3	84,0	50,0	108 022	108 022 C	1
23,0	MT 2 / 3	84,0	50,0	108 023	108 023 C	1
24,0	MT 2 / 3	84,0	50,0	108 024	108 024 C	1
25,0	MT 2 / 3	84,0	50,0	108 025	108 025 C	1
26,0	MT 2 / 3	84,0	50,0	108 026	108 026 C	1
27,0	MT 2 / 3	84,0	50,0	108 027	108 027 C	1
28,0	MT 2 / 3	84,0	50,0	108 028	108 028 C	1
29,0	MT 2 / 3	84,0	50,0	108 029	108 029 C	1
30,0	MT 2 / 3	84,0	50,0	108 030	108 030 C	1
31,0	MT 2 / 3	84,0	50,0	108 031	108 031 C	1
32,0	MT 2 / 3	84,0	50,0	108 032	108 032 C	1
33,0	MT 2 / 3	84,0	50,0	108 033	108 033 C	1
34,0	MT 2 / 3	84,0	50,0	108 034	108 034 C	1
35,0	MT 2 / 3	84,0	50,0	108 035	108 035 C	1
36,0	MT 2 / 3	84,0	50,0	108 036	108 036 C	1
37,0	MT 2 / 3	84,0	50,0	108 037	108 037 C	1
38,0	MT 2 / 3	84,0	50,0	108 038	108 038 C	1
39,0	MT 2 / 3	84,0	50,0	108 039	108 039 C	1
40,0	MT 2 / 3	84,0	50,0	108 040	108 040 C	1
41,0	MT 2 / 3	84,0	50,0	108 041	108 041 C	1
42,0	MT 2 / 3	84,0	50,0	108 042	108 042 C	1
43,0	MT 2 / 3	84,0	50,0	108 043	108 043 C	1
44,0	MT 2 / 3	84,0	50,0	108 044	108 044 C	1
45,0	MT 2 / 3	84,0	50,0	108 045	108 045 C	1
46,0	MT 2 / 3	84,0	50,0	108 046	108 046 C	1
47,0	MT 2 / 3	84,0	50,0	108 047	108 047 C	1
48,0	MT 2 / 3	84,0	50,0	108 048	108 048 C	1
49,0	MT 2 / 3	84,0	50,0	108 049	108 049 C	1
50,0	MT 2 / 3	84,0	50,0	108 050	108 050 C	1



Ø1 mm	Ø2 mm	L1 mm	Cutting depth mm	TC	TC Tecrona	
51,0	MT 2 / 3	84,0	50,0	108 051	108 051 C	1
52,0	MT 2 / 3	84,0	50,0	108 052	108 052 C	1
53,0	MT 2 / 3	84,0	50,0	108 053	108 053 C	1
54,0	MT 2 / 3	84,0	50,0	108 054	108 054 C	1
55,0	MT 2 / 3	84,0	50,0	108 055	108 055 C	1
60,0	MT 2 / 3	84,0	50,0	108 060	108 060 C	1
61,0	MT 2 / 3	84,0	50,0	108 061	108 061 C	1
63,0	MT 2 / 3	84,0	50,0	108 063	108 063 C	1
65,0	MT 2 / 3	84,0	50,0	108 065	108 065 C	1
68,0	MT 2 / 3	84,0	50,0	108 068	108 068 C	1
70,0	MT 2 / 3	84,0	50,0	108 070	108 070 C	1
71,0	MT 2 / 3	84,0	50,0	108 071	108 071 C	1
75,0	MT 2 / 3	84,0	50,0	108 075	108 075 C	1
80,0	MT 2 / 3	84,0	50,0	108 080	108 080 C	1

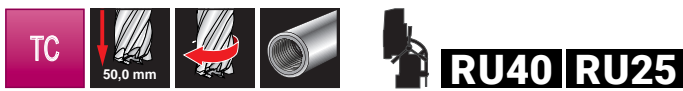

Set of core drills with tungsten-carbide cutting edges and threaded retainer in plastic case



	TC
8-piece set of core drills with tungsten-carbide cutting edges	108 823
8 core drills with tungsten-carbide and threaded retainer Ø 12,0 mm - 14,0 mm - 16,0 mm - 18,0 mm 20,0 mm - 22,0 mm - 24,0 mm - 26,0 mm	

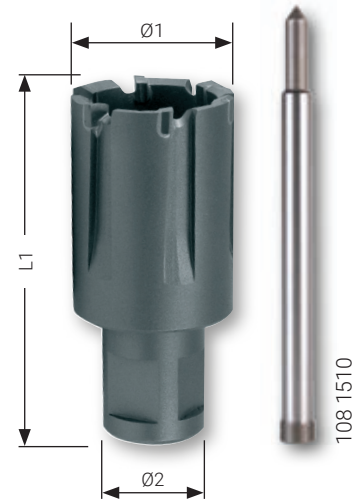

Core drills with tungsten-carbide cutting edges and Weldon shank (3/4") for railway tracks, cutting depth 30,0 mm

Can be used on all track drilling machines. The cutting geometry has been specially optimized for heavy duty chip removal from railway tracks, thus makes efficient use possible.

Ejector pin: Article no. 108 1510 (Ø 8,0 x 81,0 mm)

Packing unit: individual plastic pack

Steel (N/mm ²) < 900		
Steel (N/mm ²) < 1100	■	■
Steel (N/mm ²) < 1300	□	■
Rust-resistant steel		
Aluminium		

Brass		
Bronze		
Plastics		
Cast iron		
Titanium alloyed		

Ø1 mm	Ø2 mm	L1 mm	Cutting depth mm	TC	TC Tecrona	
19,0	19,0	63,0	30,0	108 1519	108 1519 C	1
20,0	19,0	63,0	30,0	108 1520	108 1520 C	1
21,0	19,0	63,0	30,0	108 1521	108 1521 C	1
22,0	19,0	63,0	30,0	108 1522	108 1522 C	1
23,0	19,0	63,0	30,0	108 1523	108 1523 C	1
24,0	19,0	63,0	30,0	108 1524	108 1524 C	1
25,0	19,0	63,0	30,0	108 1525	108 1525 C	1
26,0	19,0	63,0	30,0	108 1526	108 1526 C	1
26,5	19,0	63,0	30,0	108 15265	108 15265 C	1
27,0	19,0	63,0	30,0	108 1527	108 1527 C	1
27,5	19,0	63,0	30,0	108 15275	108 15275 C	1
28,0	19,0	63,0	30,0	108 1528	108 1528 C	1
29,0	19,0	63,0	30,0	108 1529	108 1529 C	1
30,0	19,0	63,0	30,0	108 1530	108 1530 C	1
31,0	19,0	63,0	30,0	108 1531	108 1531 C	1
32,0	19,0	63,0	30,0	108 1532	108 1532 C	1
33,0	19,0	63,0	30,0	108 1533	108 1533 C	1
34,0	19,0	63,0	30,0	108 1534	108 1534 C	1
36,0	19,0	63,0	30,0	108 1536	108 1536 C	1



Ejector pins for core drills



Packing unit: individual plastic pack



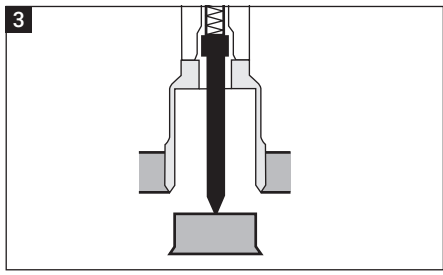
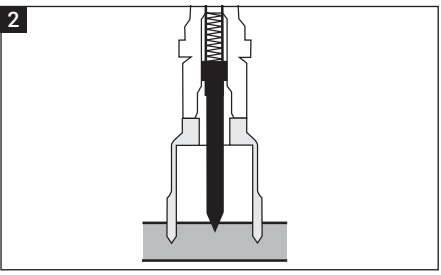
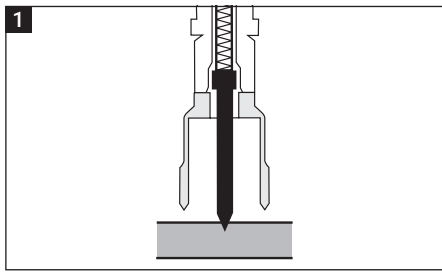

- 1 Centring:**
Position the ejector pin centrally on the centre punch.
Now the machine is in the correct drilling position. Please turn on magnet now.
- 2 Coolant supply:**
The cutting oil is supplied through the ejector pin by the automatic internal lubrication and is issued optimally to the cutting edges.
- 3 Ejecting:**
In the final phase, the drill core is pushed from the borehole by the spring pretensioned ejector pin.



Ejector pins for core drills HSS

	Core drills cutting depth mm		
Ejector pin Ø 6,35 x 77,0 mm for core drills HSS with Weldon shank (3/4")	30,0	108 304	1
Ejector pin Ø 6,35 x 87,0 mm for core drills HSS / TC with Quick IN-shank	35,0 / 50,0	108 306	1
Ejector pin Ø 6,35 x 102,0 mm for core drills HSS / TC with Weldon shank (3/4")	55,0	108 305	1
Ejector pin Ø 8,0 x 155,0 mm for core drills HSS with Weldon shank (3/4")	110,0	108 2000	1

Ejector pins for core drills TC

	Core drills cutting depth mm		
Ejector pin Ø 8,0 x 81,0 mm for core drills TC with Weldon shank (3/4") for railway tracks	30,0	108 1510	1
Ejector pin Ø 6,35 x 87,0 mm for core drills HSS / TC with Quick IN-shank	35,0 / 50,0	108 306	1
Ejector pin Ø 8,0 x 112,0 mm for core drills TC with Weldon shank (3/4")	50,0	108 701	1
Ejector pin Ø 6,35 x 123,0 mm for core drills TC with Weldon- (3/4") and Quick IN-shank	50,0 + Adapter	108 110	1
Ejector pin Ø 6,35 x 102,0 mm for core drills HSS / TC with Weldon shank (3/4")	55,0	108 305	1



Recommended cutting speeds for tungsten-carbide core drills

Material:		High carbon struc. steel up to 700 N/mm ²	Alloyed steel up to 1000 N/mm ²	Cast iron over 250 N/mm ²	CuZn-alloy brittle	CuZn-alloy tough	Aluminium alloy up to 11% Si	Thermo-plastics	Duro-plastics
Vc = m/min		50	35	40	60	40	60	45	40
Coolant:		Cutting spray	Cutting spray	Compressed air	Compressed air	Compressed air	Cutting spray	Water	Compressed air
Ø mm	Ø inch	r.p.m.	r.p.m.	r.p.m.	r.p.m.	r.p.m.	r.p.m.	r.p.m.	r.p.m.
12,0	15/32	1327	929	1062	1592	265	1592	1194	1062
13,0	33/64	1225	857	980	1470	245	1470	1102	980
14,0	35/64	1137	796	910	1365	227	1365	1024	910
15,0	19/32	1062	743	849	1274	212	1274	955	849
16,0	5/8	995	697	796	1194	199	1194	896	796
17,0	34/64	937	656	749	1124	187	1124	843	749
18,0	45/64	885	619	708	1062	177	1062	796	708
19,0	3/4	838	587	670	1006	168	1006	754	670
20,0	25/32	796	557	637	955	159	955	717	637
21,0	3/4	758	531	607	910	152	910	682	607
22,0	7/8	724	507	579	869	145	869	651	579
23,0	13/16	692	485	554	831	138	831	623	554
24,0	15/16	663	464	531	796	133	796	597	531
25,0	63/64	637	446	510	764	127	764	573	510
26,0	1 1/32	612	429	490	735	122	735	551	490
27,0	1 1/16	590	413	472	708	118	708	531	472
28,0	1 3/32	569	398	455	682	114	682	512	455
29,0	1 9/64	549	384	439	659	110	659	494	439
30,0	1 3/16	531	372	425	637	106	637	478	425
31,0	1 7/32	514	360	411	616	103	616	462	411
32,0	1 17/64	498	348	398	597	100	597	448	398
33,0	1 19/64	483	338	386	579	97	579	434	386
34,0	1 11/32	468	328	375	562	94	562	422	375
35,0	1 3/8	455	318	364	546	91	546	409	364
36,0	1 27/64	442	310	354	531	88	531	398	354
37,0	1 29/64	430	301	344	516	86	516	387	344
38,0	1 1/2	419	293	335	503	84	503	377	335
39,0	1 17/32	408	286	327	490	82	490	367	327
40,0	1 37/64	398	279	318	478	80	478	358	318
41,0	1 39/64	388	272	311	466	78	466	350	311
42,0	1 21/32	379	265	303	455	76	455	341	303
43,0	1 11/16	370	259	296	444	74	444	333	296
44,0	1 47/64	362	253	290	434	72	434	326	290
45,0	1 25/32	354	248	283	425	71	425	318	283
46,0	1 13/16	346	242	277	415	69	415	312	277
47,0	1 55/64	339	237	271	407	68	407	305	271
48,0	1 57/64	332	232	265	398	66	398	299	265
49,0	1 15/16	325	227	260	390	65	390	292	260
50,0	1 31/32	318	223	255	382	64	382	287	255
51,0	2	312	219	250	375	62	375	281	250
52,0	2 3/64	306	214	245	367	61	367	276	245
53,0	2 3/32	300	210	240	361	60	361	270	240
54,0	2 1/8	295	206	236	354	59	354	265	236
55,0	2 5/32	290	203	232	347	58	347	261	232
60,0	2 3/8	265	186	212	318	53	318	239	212
61,0	2 13/32	261	183	209	313	52	313	235	209
65,0	2 9/16	245	171	196	294	49	294	220	196
68,0	2 43/64	234	164	187	281	47	281	211	187
70,0	2 3/4	227	159	182	273	45	273	205	182
71,0	2 51/64	224	157	179	269	45	269	202	179
75,0	2 61/64	212	149	170	255	42	255	191	170
80,0	3 5/32	199	139	159	239	40	239	179	159
85,0	3 11/32	187	131	150	225	37	225	169	150
90,0	3 35/64	177	124	142	212	35	212	159	142
95,0	3 47/64	168	117	134	201	34	201	151	134
100,0	3 15/16	159	111	127	191	32	191	143	127



RUKO GmbH PRÄZISIONSWERKZEUGE

ABOUT

VIDEOS

PLAYLISTS

CHANNALS

ABOUT

Uploads ▾

PLAY ALL

ULTIMATECUT[®]
Stufenbohrer

- 5-in-1-Werkzeug
- Bis zu 75% Zeitersparnis
- Ultimative Flexibilität

2:14

Der neue RUKO ULTIMATECUT Stufenbohrer

👍 SHARE 📌 SAVE ...

ULTIMATECUT[®]
Step drill

- 5 in 1 tool
- Up to 75% time savings
- Ultimate flexibility

2:14

The new RUKO ULTIMATECUT step drill

👍 SHARE 📌 SAVE ...

RUKO

CELEBRATING
45
YEARS
OF PRECISION
1974

RUKO feiert 45-jähriges Firmenjubiläum

👍 SHARE 📌 SAVE ...

Step drill

- + Up to 4 times more holes
- + Smooth and quiet drilling

NEXT GENERATION
2:31

The new RUKO step drill generation

Foret Étagées

- + Jusqu'à 4 fois plus de perçages
- + Processus de perçage plus facile

NEXT GENERATION
2:31

La nouvelle génération de forets étagés RUKO

How do I punch a hole in the sink

How do I punch a hole in the sink



SUBSCRIBE NOW



☰ SORT BY

RUKO



Wie versenke ich eine Zylinderkopfschraube

1:48

Wie versenke ich eine Zylinderkopfschraube

👍 ➡️ SHARE 📌 SAVE ...

RUKO



How to countersink a cylinder-head screw

1:48

How to countersink a cylinder-head screw

👍 ➡️ SHARE 📌 SAVE ...

RUKO



Stufenbohrer

- + Bis zu 4-mal mehr Bohrungen
- + Leichter Bohrvorgang

NEXT GENERATION

2:31

Die neue RUKO Stufenbohrer Generation

👍 ➡️ SHARE 📌 SAVE ...

RUKO



Wie stanze ich ein Loch in die Spüle

1:27

Wie stanze ich ein Loch in die Spüle

RUKO



ULTIMATECUT® Kegelsenker

- + Bis zu 30% Zeitersparnis
- + Bis zu 2-mal mehr Senkungen
- + Optimales, glattes Senkergebnis

Der neue RUKO ULTIMATECUT

RUKO



ULTIMATECUT®

RUKO TV



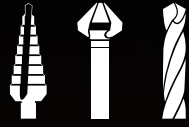

CELEBRATING

45

YEARS

OF PRECISION

1974



RUKO GmbH PRÄZISIONSWERKZEUGE

Robert-Bosch-Straße 7-11
71088 Holzgerlingen
Germany

+49(0) 7031 / 6800-0
www.ruko.de | info@ruko.de



© All rights reserved.

This catalogue is protected by copyright law and remains solely our property. We reserve the right to make changes to technical data. Images are non-binding. Liability for printing errors is excluded. This catalogue invalidates any previous editions.

1. Edition September 2019 | English (EN)