



Model Number

NDS-F146-8E2-V1

Inductive transmitter system

Features

- 8 channels
- 8 sensor inputs
- Fast, flexible installation/separation

Technical data

Nominal ratings

Number of signal channels	8
Signal transfer direction	from secondary side to primary side
Sensor supply voltage	12 V ± 10 % , overload and short-circuit resistant
Ripple	≤ 5 %
Transfer power	max. 2.5 W (1.5 W at 5 mm)
Load step	≤ 100 mA

Functional safety related parameters

MTTF _d	465 a
Mission Time (T _M)	20 a
Diagnostic Coverage (DC)	0 %

Input

Number	8
Input type	Input for sensor signals
Connectable sensor types	DC, 3-wire , PNP (switched high)
Input current	≤ 1 mA
Internal resistor	≥ 15 kΩ

Ambient conditions

Ambient temperature	0 ... 50 °C (32 ... 122 °F)
Storage temperature	-25 ... 85 °C (-13 ... 185 °F)

Mechanical specifications

Degree of protection	IP65
Material	
Housing	PA 66-FR
Installation	screw mounting
Mass	140 g

General information

Note	Maximum cable length between WIS module and WIS transmitter must not exceed 5 m.
------	--

Compliance with standards and directives

Directive conformity	
EMC Directive 89/336/EEC	EN 61000-6-2:2001, EN 61000-6-4:2001, EN 50295:1999
Standard conformity	
Standards	EN 60947-5-2:2007 IEC 60947-5-2:2007

Approvals and certificates

CCC approval	CCC approval / marking not required for products rated ≤36 V
--------------	--

Dimensions

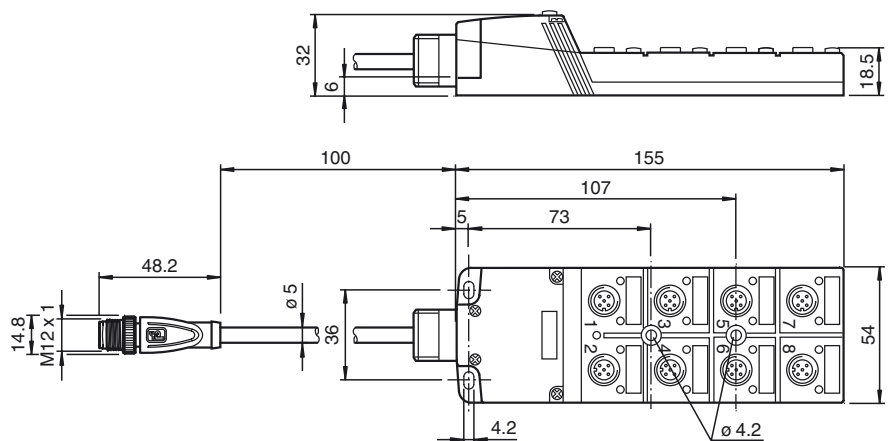

Electrical Connection

Connection:

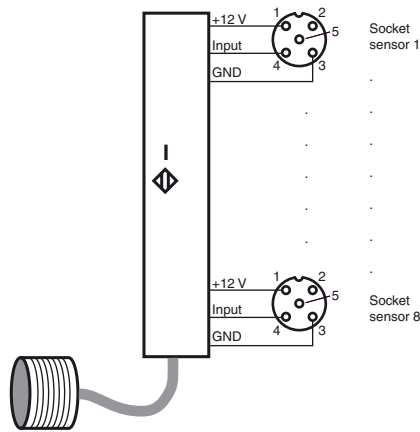

Functional description

A WIS (wireless inductive system) inductive transfer system always consists of the following four components:

- WIS primary module
- WIS primary transmitter
- WIS secondary transmitter
- WIS secondary module

The WIS primary module is installed in the stationary component and is connected to a downstream control (i.e., PLC). The WIS primary transmitter connected to the WIS primary module. The WIS secondary transmitter and the WIS secondary module that is connected to it are installed in the moveable part of the component. The WIS secondary module disposes of connection capabilities for several sensors. If the two transmitters are located in front of each other within the system range, then electric power is transferred from the primary side to the secondary side. The sensors attached to the WIS secondary module are now supplied with electric energy and begin to operate. The sensor output signals are transmitted in the opposite direction from the secondary side to the primary side and are separately available on the WIS primary module output terminals for further processing by the equipment control. The sensor signal status is also displayed by LEDs that correspond to the sensor channels.

A separate output signal Tx on the WIS primary module indicates the communication status. A high signal indicates communication between the WIS transmitters. This is also indicated by a glowing LED Tx.

Power transfer and communication in the system can be activated and deactivated on the WIS primary module with the EN input .

Input signal on EN	Function
+ UB (24 V DC)	Transfer activated
GND or open.	Transfer deactivated

Function schematic

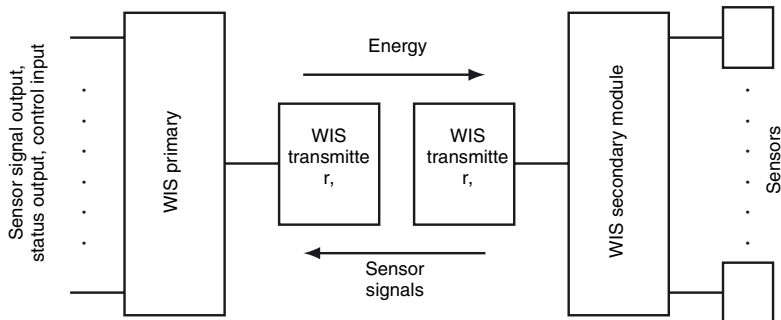

The sum of the currents of all sensors attached to the WIS secondary module must not be greater than the maximum transferable current. This is calculated by dividing the transferable power by the 12 V provided by the transmitters.

Release date: 2014-06-23 15:49 Date of issue: 2014-06-23 200663_eng.xml