

The new anti-scratch scooter with autobalance / safety technology based on dynamic balancing principles calculating the user's center of gravity using gyroscope and acceleration sensors.

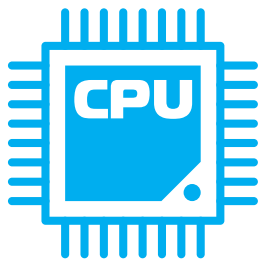

**New CPU with
AUTOMATIC
STABILISATION**



**BATTERY
MANAGEMENT
SYSTEM**



1. Slow down function to zero km, if battery is empty
2. Speedup function smart control, if battery is low

Autobalance mode means that the Hoverboard automatically adjusts itself to help provide the smoothest and most comfortable ride possible while providing a high level of safety

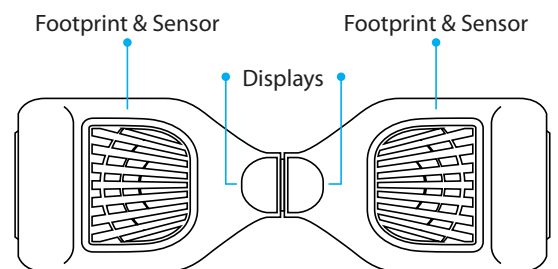
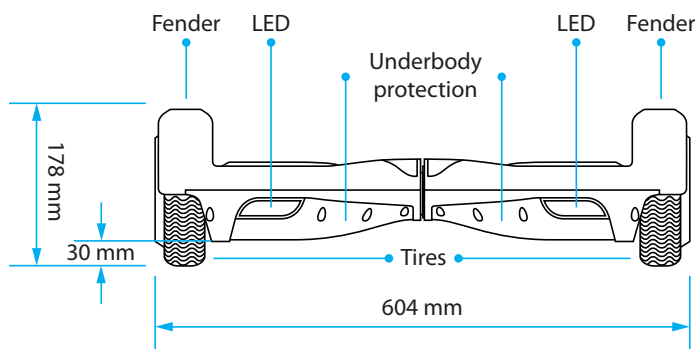

- ▶ Max. speed: up to 15 km/h
- ▶ Motor power: 2 x 250 W
- ▶ Battery type: Li-Ion

- ▶ Battery: 2.0Ah, 36V
- ▶ Max. load: 100 kg
- ▶ Charging time: 3-4 h

- ▶ Material: Anti-scratch plastic
- ▶ Size: 60.4 x 18.6 x 17.8 cm
- ▶ Tire size: 6.5"