



Main

Range compatibility	Lexium 28
Product or component type	Servo motor
Device short name	BCH2

Complementary

Maximum mechanical speed	3000 rpm
[Us] rated supply voltage	220 V
Network number of phases	Single phase Three phase
Continuous stall current	6.18 A
Continuous stall torque	7.16 N.M for LXM26D at 7 A, 220 V, single phase 7.16 N.M for LXM26D at 7 A, 220 V, three phase 7.16 N.M for LXM28... at 7 A, 220 V, single phase 7.16 N.m for LXM28... at 7 A, 220 V, three phase
Continuous power	1500 W
Peak stall torque	21.48 N.M for LXM26D at 7 A, 220 V, single phase 21.48 N.M for LXM26D at 7 A, 220 V, three phase 21.48 N.M for LXM28... at 7 A, 220 V, single phase 21.48 N.m for LXM28... at 7 A, 220 V, three phase
Nominal output power	1500 W for LXM26D at 7 A, 220 V, single phase 1500 W for LXM26D at 7 A, 220 V, three phase 1500 W for LXM28... at 7 A, 220 V, single phase 1500 W for LXM28... at 7 A, 220 V, three phase
Nominal torque	7.16 N.M for LXM26D at 7 A, 220 V, single phase 7.16 N.M for LXM26D at 7 A, 220 V, three phase 7.16 N.M for LXM28... at 7 A, 220 V, single phase 7.16 N.m for LXM28... at 7 A, 220 V, three phase
Nominal speed	2000 rpm for LXM26D at 7 A, 220 V, single phase 2000 rpm for LXM26D at 7 A, 220 V, three phase 2000 rpm for LXM28... at 7 A, 220 V, single phase 2000 rpm for LXM28... at 7 A, 220 V, three phase
Maximum current Irms	20.31 A for LXM28... at 1.5 kW, 220 V
Maximum permanent current	6.74 A
Product compatibility	LXM26D servo drive motor at 1.5 kW, 220 V, single phase LXM26D servo drive motor at 1.5 kW, 220 V, three phase LXM28... servo drive motor at 1.5 kW, 220 V, single phase LXM28... servo drive motor at 1.5 kW, 220 V, three phase
Shaft end	Keyed
Shaft diameter	22 mm
Shaft length	55 mm
Key width	8 mm
Feedback type	20 bits single turn absolute encoder
Holding brake	With
Holding torque	9.6 N.m built-in
Mounting support	Asian standard flange

Motor flange size	130 mm
Electrical connection	Connector MIL
Torque constant	1.16 N.m/A at 20 °C
Back emf constant	70 V/krpm at 20 °C
Rotor inertia	10 kg.cm ²
Stator resistance	0.64 Ohm at 20 °C
Stator inductance	6.4 mH at 20 °C
Stator electrical time constant	10 ms at 20 °C
Maximum radial force Fr	670 N at 2000 rpm
Maximum axial force Fa	200 N
Brake pull-in power	19.7 W
Type of cooling	Natural convection
Length	202 mm
Number of motor stacks	3
Centring collar diameter	110 mm
Centring collar depth	8 mm
Number of mounting holes	4
Mounting holes diameter	9.2 mm
Circle diameter of the mounting holes	145 mm
Distance shaft shoulder-flange	8 mm
Net weight	8.8 kg

Environment

IP degree of protection	IP50 IM V3 IP65 IM B5, IM V1
Ambient air temperature for operation	0...40 °C

Packing Units

Unit Type of Package 1	PCE
Number of Units in Package 1	1
Package 1 Weight	10.71 kg
Package 1 Height	19.2 cm
Package 1 width	23.3 cm
Package 1 Length	36.1 cm
Unit Type of Package 2	S06
Number of Units in Package 2	9
Package 2 Weight	96.39 kg
Package 2 Height	73.5 cm
Package 2 width	60.0 cm
Package 2 Length	80.0 cm

Offer Sustainability

Sustainable offer status	Green Premium product
REACH Regulation	 REACH Declaration
REACH free of SVHC	Yes
EU RoHS Directive	Pro-active compliance (Product out of EU RoHS legal scope)  EU RoHS Declaration
Mercury free	Yes
RoHS exemption information	 Yes
China RoHS Regulation	 China RoHS Declaration
Environmental Disclosure	 Product Environmental Profile
Circularity Profile	 End Of Life Information

WEEE	The product must be disposed on European Union markets following specific waste collection and never end up in rubbish bins
PVC free	Yes
Contractual warranty	
Warranty	18 months

Dimensions

Dimensions of Motor

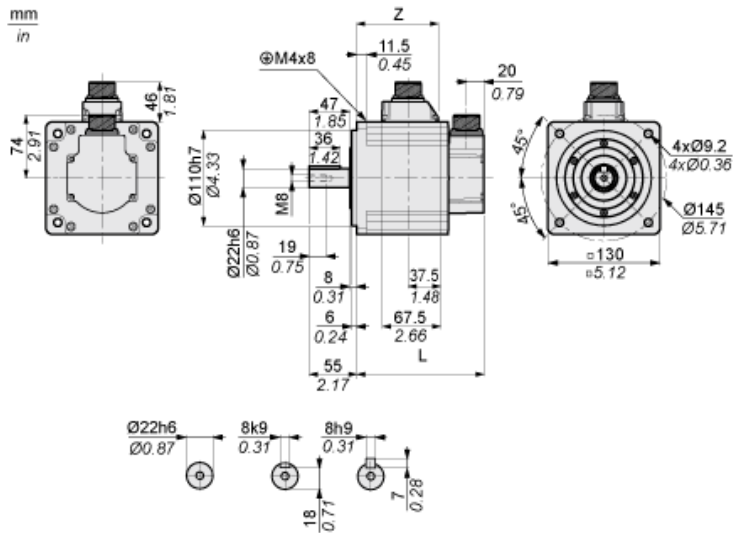

	mm	in.
L (without holding brake)	167	6.57
L (with holding brake)	202	7.95
Z	114.5	4.51

Torque/Speed Curves with 230 V Single/Three Phase Supply Voltage

Servo Motor with LXM28AU15●●● Servo Drive

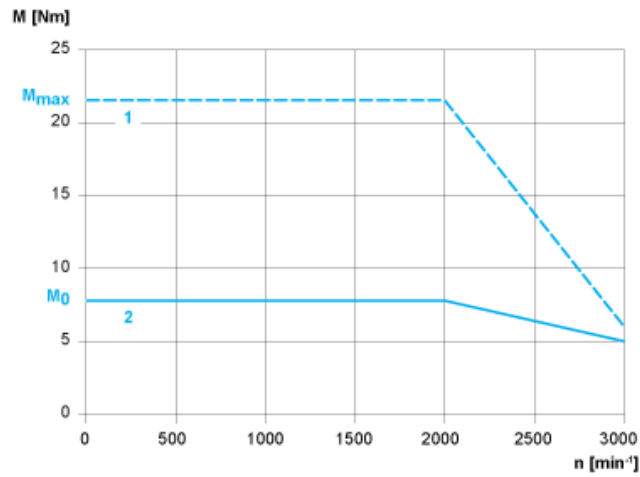

- 1 : Peak torque
- 2 : Continuous torque