

3D Sensor

MLBS203

Part Number



- 10 Gbit/s interface for high speed data transfer
- 12 MP resolution
- Large measuring volumes (up to 1300 × 920 × 800 mm)
- Short recording times of up to 0.44 s

ShapeDrive MLBS 3D Sensors are ideally suited for applications with large measuring volumes. The six models in this series are available in two performance classes with camera resolutions of 5 and 12 megapixels. Thanks to the rugged IP67 housing, all ShapeDrive sensors are ideally suited for use in industrial environments. With its 10 Gigabit Ethernet interface and three measuring ranges in each performance class, ShapeDrive is also distinguished by great diversity and high speed.

ShapeDrive

Technical Data

Optical Data	
Working range Z	1550...2350 mm
Measuring range Z	800 mm
Measuring range X	1300 mm
Measuring range Y	860 mm
Resolution Z	70 µm
Resolution X/Y	339 µm
Camera Resolution	4096 × 3000 Pixel
Light Source	LED (blue)
Wavelength	460 nm
Service Life (T = +25 °C)	20000 h
Risk Group (EN 62471)	2
Max. Ambient Light	5000 Lux
Electrical Data	
Supply Voltage	18...30 V DC
Max. Current Consumption (Ub = 24 V)	5 A
Recording duration	0,44...2,15 s
Temperature Range	0...35 °C
Storage temperature	-5...70 °C
Short Circuit Protection	yes
Reverse Polarity Protection	yes
Interface	Ethernet TCP/IP
Baud Rate	100 Mbit/s
Baud Rate (10 GbE)	10 Gbit/s
Protection Class	III
Mechanical Data	
Housing Material	Aluminium; Plastic
Degree of Protection	IP67
Connection	M12 × 1; 12-pin
Type of Connection Ethernet	M12 × 1; 8-pin, X-cod.
Optic Cover	Plastic
Weight	4500 g
Web server	yes
Connection Diagram No.	238 1022
Control Panel No.	A41
Suitable Connection Equipment No.	50 87

Complementary Products

Cooling Unit ZLBK001

Cooling Unit ZLBK002

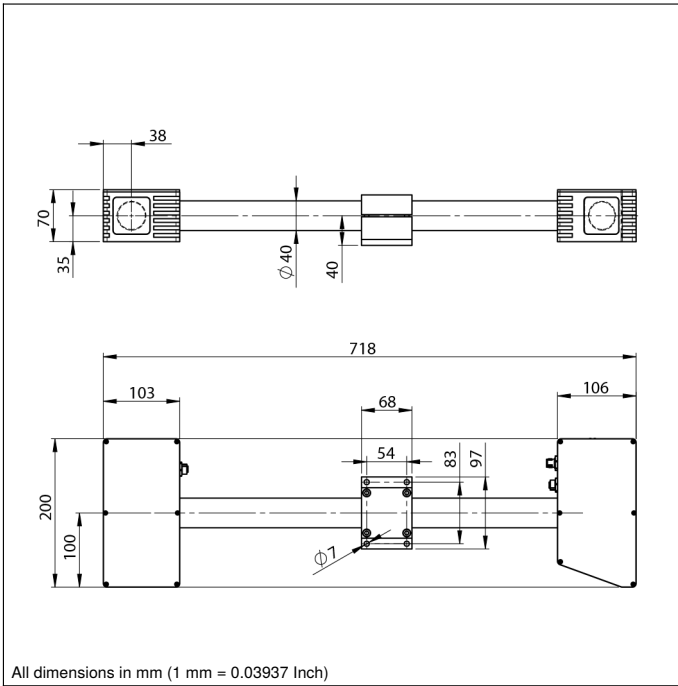

All dimensions in mm (1 mm = 0.03937 Inch)

Ctrl. Panel

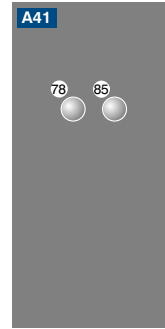

78 = Module status
85 = Link/Act LED

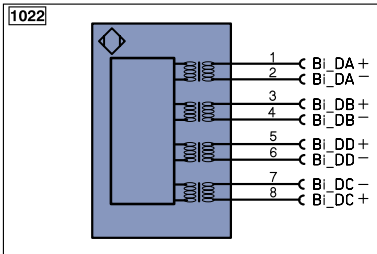
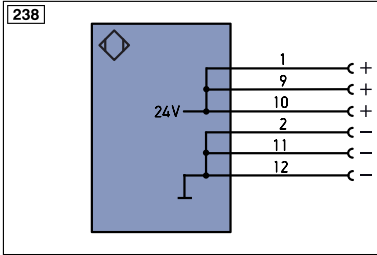

Legend

+	Supply Voltage +	PT	Platinum measuring resistor	EN ^A ES42Z	Encoder A/ \bar{A} (TTL)
-	Supply Voltage 0 V	nc	not connected	EN ^B ES42Z	Encoder B/ \bar{B} (TTL)
~	Supply Voltage (AC Voltage)	U	Test Input	EN ^A	Encoder A
A	Switching Output (NO)	\bar{U}	Test Input inverted	EN ^B	Encoder B
\bar{A}	Switching Output (NC)	W	Trigger Input	A _{MIN}	Digital output MIN
V	Contamination/Error Output (NO)	W-	Ground for the Trigger Input	A _{MAX}	Digital output MAX
\bar{V}	Contamination/Error Output (NC)	O	Analog Output	A _{OK}	Digital output OK
E	Input (analog or digital)	O-	Ground for the Analog Output	SY _{in}	Synchronization In
T	Teach Input	BZ	Block Discharge	SY _{OUT}	Synchronization OUT
Z	Time Delay (activation)	AWV	Valve Output	OLT	Brightness output
S	Shielding	a	Valve Control Output +	M	Maintenance reserved
RxD	Interface Receive Path	b	Valve Control Output 0 V	rsv	reserved
TxD	Interface Send Path	SY	Synchronization	Wire Colors according to IEC 60757	
RDY	Ready	SY-	Ground for the Synchronization	BK	Black
GND	Ground	E+	Receiver-Line	BN	Brown
CL	Clock	S+	Emitter-Line	RD	Red
E/A	Output/Input programmable	\pm	Grounding	OG	Orange
	IO-Link	S _n R	Switching Distance Reduction	YE	Yellow
PoE	Power over Ethernet	Rx+/-	Ethernet Receive Path	GN	Green
IN	Safety Input	Tx+/-	Ethernet Send Path	BU	Blue
OSSD	Safety Output	Bus	Interfaces-Bus A(+)/B(-)	VT	Violet
Signal	Signal Output	L _a	Emitted Light disengageable	GY	Grey
Bi_D+/-	Ethernet Gigabit bidirect. data line (A-D)	Mag	Magnet activation	WH	White
EN ⁰ ES42Z	Encoder 0-pulse 0-0 (TTL)	RES	Input confirmation	PK	Pink
		EDM	Contactur Monitoring	GNYE	Green/Yellow

Measuring Volume

