



# DIN Signal female connector



## General information

Design	IEC 60603-2, types: B, C, 2B, 2C		
No. of contacts	max. 96		
Contact spacing	2,54 mm		
Test voltage	1000V		
Contact resistance	max. 20mOhm		
Insulation resistance	min. 10 <sup>10</sup> Ohm		
Working current	1,5A at 20°C (see derating diagram)		
Temperature range	-55°C ... +125°C		
Termination technology	solder lugs, press-in, wirewrap		
Clearance & creepage distance	min. 1,2 mm each		
Insertion and withdrawal force	32-pole max. 30N	64-pole max. 60N	96-pole max. 90N
Mating cycles	PL 1 acc. to IEC 60603-2	PL 2 acc. to IEC 60603-2	PL 3 acc. to IEC 60603-2
	500 mating cycles	400 mating cycles	50 mating cycles
RoHS - compliant	Yes		
Leadfree	Yes		
Hot plugging	No		

## Insulator material

Material	PBT (thermoplastics, glass fiber reinforcement)
Color	RAL 7032 (grey)
UL classification	UL 94-V0
Material group acc. IEC 60664-1	IIIa (175 < CTI < 400)

## Contact material

Contact material	Copper alloy
Plating termination zone solder lugs	Sn
Plating termination zone press-in	Sn
Plating Wire wrap zone	Sn
Plating contact zone I	Au over Ni

## Derating diagram acc. to IEC 60512-5 (Current carrying capacity)

The current carrying capacity is limited by maximum temperature of materials for inserts and contacts including terminals.

The current capacity curve is valid for continuous, non interrupted current loaded contacts of connectors when simultaneous power on all contacts is given, without exceeding the maximum temperature.

Control and test procedures according to DIN IEC 60512-5

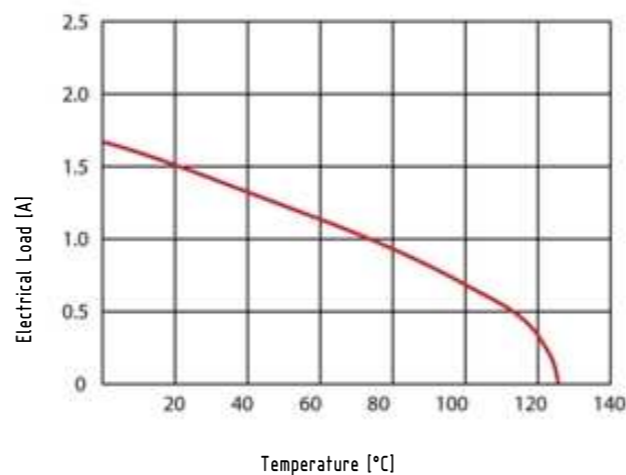

## Recommended configuration of plated through holes for press-in termination

In addition to the hot-air-level (HAL), other PCB surfaces are getting more important. Due to their different properties - such as mechanical strength and coefficient of friction - we recommend the following configuration of PCB through holes.

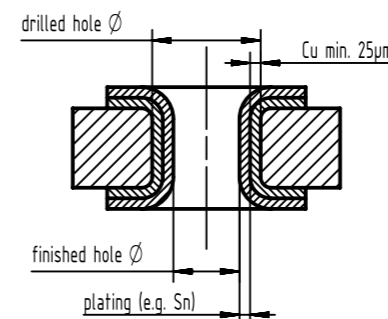

Plating Type	Drilled hole Ø	Plated hole Ø	Plating Thickness
Tin plated PCB (HAL) acc. to EN 60352-5	1,15±0,025 mm		
		Sn	max. 15 µm
Chemical tin plated PCB	1,15±0,025 mm		
		Sn	min. 0,8µm
Gold /Nickel plated PCB	1,15±0,025 mm		
		Ni	3 - 7 µm
Silver plated PCB	1,15±0,025 mm		
		Ag	0,1 - 0,3 µm
Copper plated PCB (OSP)	1,15±0,025 mm		
			0,05 - 0,12 µm

## Assembly instructions

It is highly recommended to use HARTING press-in tools to ensure a reliable press-in process. Please refer to the catalogue for tools, machines and further information about the press-in process.

## Cross section of wire wrap pins

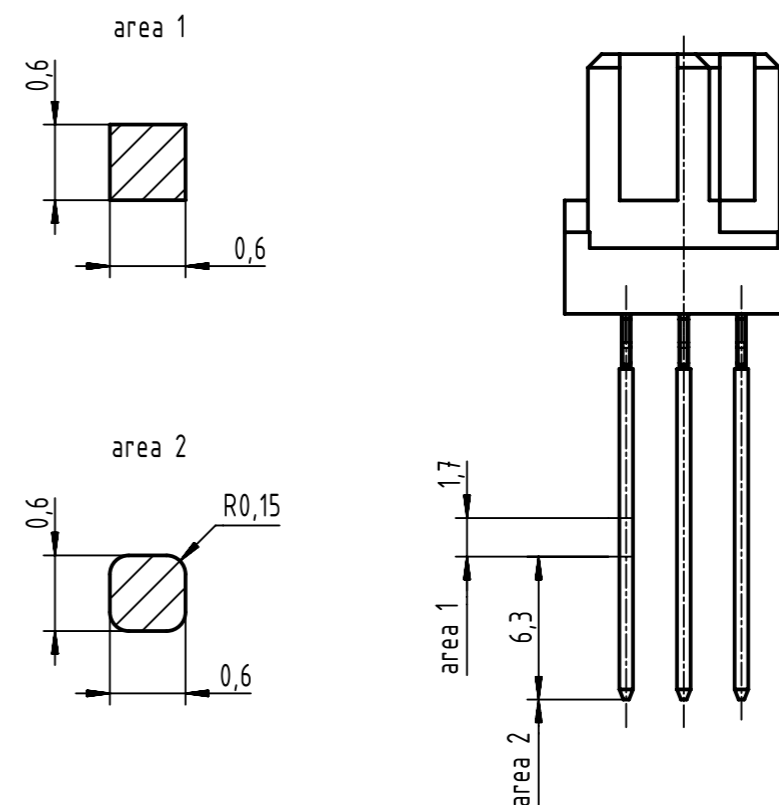

All Dimensions in mm Original Size DIN A3		Scale 1:1	Free size tol.		Ref. Sub.
All rights reserved Department EC PD - DE		Created by STORCK	Inspected by LEHNERT	Standardisation HOFFMANN	Date 2017-01-30
HARTING Electronics GmbH D-32339 Espelkamp		Title DIN Signal female connector			State Final Release
		Type DS	Number 09032100007		Doc-Key / ECM-Nr. 100660616/UGD/000/C 500000114120
					Rev. C Page 1/1