

GN 238 | Hinges with adjusting inserts

Screw-covers, die-cast zinc alloy



- 1
- 2
- 3
- 4
- 5
- 6
- 7
- 8
- 9
- 10
- 11
- 12
- 13
- 14
- 15
- 16
- 17
- 18

MATERIAL

Die-cast zinc alloy.

COLOUR

Epoxy resin coating, RAL 9005 black, matte finish.

ADJUSTING INSERTS

Hardened steel.

ROTATING PIN

AISI 303 stainless steel.

SCREW-COVERS

Technopolymer, dark grey colour, matte finish.

STANDARD EXECUTIONS

- **GN 238-BJ**: with 4 inserts for countersunk-head screws, for horizontal and vertical adjustment.
- **GN 238-EJ**: with 2 inserts for countersunk-head screws, for horizontal or vertical adjustment.
- **GN 238-NJ**: pass-through holes for countersunk-head screws, without adjusting inserts.

FEATURES AND APPLICATIONS

The adjusting inserts are designed to compensate limited misalignments of doors. Vertical and horizontal adjustments are both possible by simply setting the orientation of the inserts, thus obtaining the perfect alignment between the door and the frame.

A round ring, situated on the rear part of the adjusting inserts, offers a secure mounting by carving the knurlings on the hinge holes.

ROTATION ANGLE (APPROXIMATE VALUE)

Max 180° (-20° and +160° being 0° the condition where the two interconnected surfaces are on the same plane).

SPECIAL EXECUTIONS ON REQUEST

- GN 238-SR: epoxy resin coating, RAL 9006 grey colour, matte finish, with screw-covers in light grey colour.

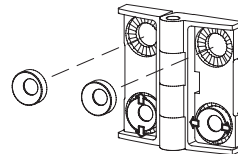
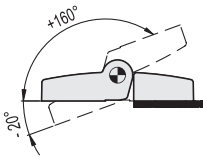
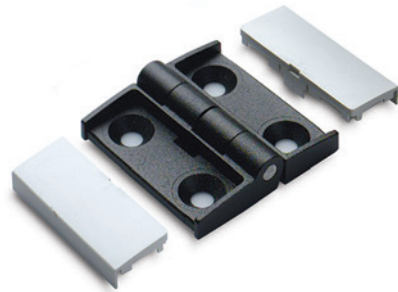

		AXIAL STRESS	RADIAL STRESS	90° ANGLED STRESS
Resistance tests				
Code	Description	Load at breakage Ra [N]	Load at breakage Rr [N]	Load at breakage R90 [N]
GN.38801	GN 238-42-42-BJ-SW	1050	1500	2100
GN.38821	GN 238-50-50-BJ-SW	1500	1500	2200
GN.38841	GN 238-60-60-BJ-SW	1500	2500	3200
GN.38805	GN 238-42-42-NJ-SW	1500	1250	1350
GN.38825	GN 238-50-50-NJ-SW	2000	1800	1900
GN.38845	GN 238-60-60-NJ-SW	2550	3700	2600
GN.38803	GN 238-42-42-EJ-SW	1200	1000	1500
GN.38823	GN 238-50-50-EJ-SW	1500	1500	1700
GN.38843	GN 238-60-60-EJ-SW	1500	2000	2000

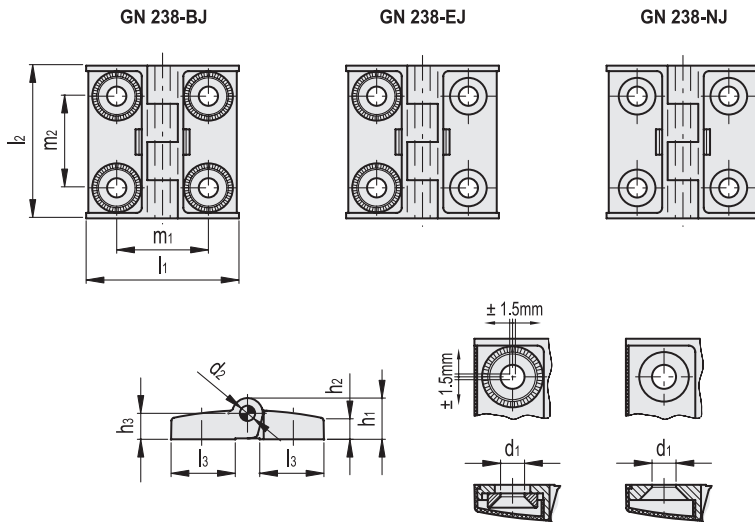

Code	Description	l1	l2	d1	d2	h1	h2	h3	l3	m1	m2	⚖
GN.38801	GN 238-42-42-BJ-SW	42	42	5.3	4	11	6.5	7.5	17	25	25	52
GN.38803	GN 238-42-42-EJ-SW	42	42	5.3	4	11	6.5	7.5	17	25	25	51
GN.38805	GN 238-42-42-NJ-SW	42	42	5.3	4	11	6.5	7.5	17	25	25	49
GN.38821	GN 238-50-50-BJ-SW	50	50	6.3	5	13.5	7	8.5	21	30	30	91
GN.38823	GN 238-50-50-EJ-SW	50	50	6.3	5	13.5	7	8.5	21	30	30	90
GN.38825	GN 238-50-50-NJ-SW	50	50	6.3	5	13.5	7	8.5	21	30	30	88
GN.38841	GN 238-60-60-BJ-SW	60	60	6.3	6	17	9	11.5	26	36	36	171
GN.38843	GN 238-60-60-EJ-SW	60	60	6.3	6	17	9	11.5	26	36	36	170
GN.38845	GN 238-60-60-NJ-SW	60	60	6.3	6	17	9	11.5	26	36	36	168