

ALPHA 160/400/630 SUPPORT EXTENSIONS, 7.5MM
 BULK PACK: 100 UNITS FOR PLUGGING ON
 SUPPORT

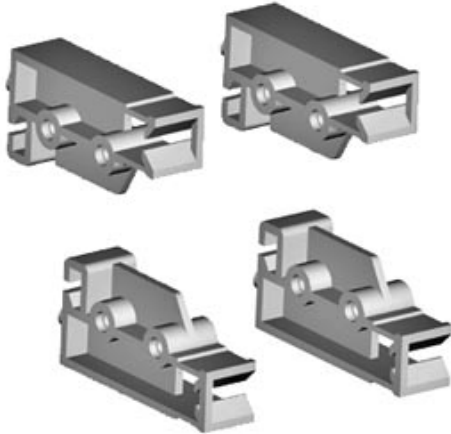

Accessories

accessories	others
-------------	--------

General Product Approval	Declaration of Conformity	Test Certificates
--------------------------	---------------------------	-------------------



[other](#)



[Special Test Certificate](#)

Further information

Information- and Downloadcenter (Catalogs, Brochures,...)
<http://www.siemens.com/lowvoltage/catalogs>

Industry Mall (Online ordering system)
<https://eb.automation.siemens.com/mall/en/WW/Catalog/Product/8GK99110KK03>

Service&Support (Manuals, Certificates, Characteristics, FAQs,...)
<http://support.automation.siemens.com/WW/view/en/8GK99110KK03/all>

Image database (product images, 2D dimension drawings, 3D models, device circuit diagrams, ...)
http://www.automation.siemens.com/bilddb/cax_en.aspx?mlfb=8GK99110KK03

CAX-Online-Generator
<http://www.siemens.com/cax>

Tender specifications
<http://ausschreibungstexte.siemens.com/tiplv>

last modified: 11.03.2015