

Click [here](#) to ask about the production status of specific part numbers.

DS28E18 Evaluation System

Evaluates: DS28E18

General Description

The DS28E18 evaluation system (EV system) provides the special hardware and software system to exercise the features of the DS28E18 1-Wire®-to-I²C/SPI bridge with command sequencer IC. The EV system consists of a DS28E18 EV kit board, a DS7505 peripheral module board, a MAX31722 peripheral module board, and a DS9481P-300# USB-to-1-Wire adapter for PC connectivity. The EV kit is compatible with Windows® operating systems.

EV System Contents

- DS28E18 EV kit board (Figure 1)
- DS9481P-300# USB-to-1-Wire adapter
- MAX31722 PMOD board
- DS7505 PMOD board

Features

- Driver Support for Windows 10/8/7
- Fully Compliant with USB 2.0 Specification
- USB Powered with No External Power Supply Required
- Extended SPI/I²C Peripheral Module Connector for Rapid Prototyping of SPI/I²C Slaves

Ordering Information appears at end of data sheet.

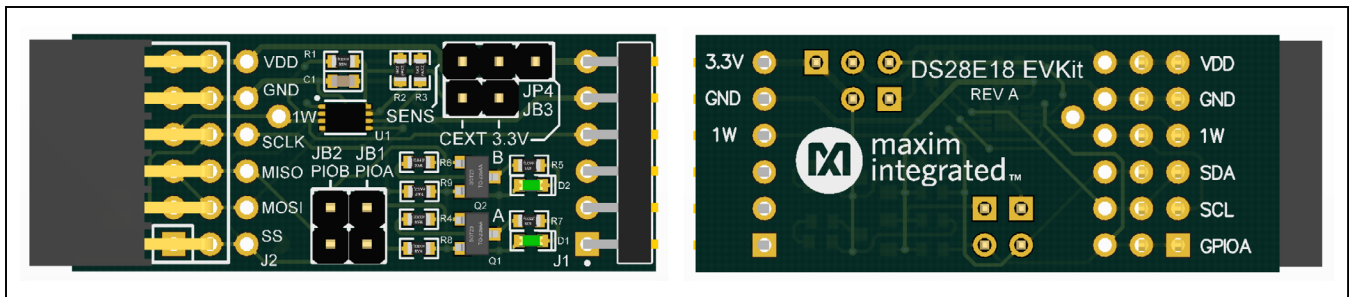

Figure 1. DS28E18 EV Kit Board

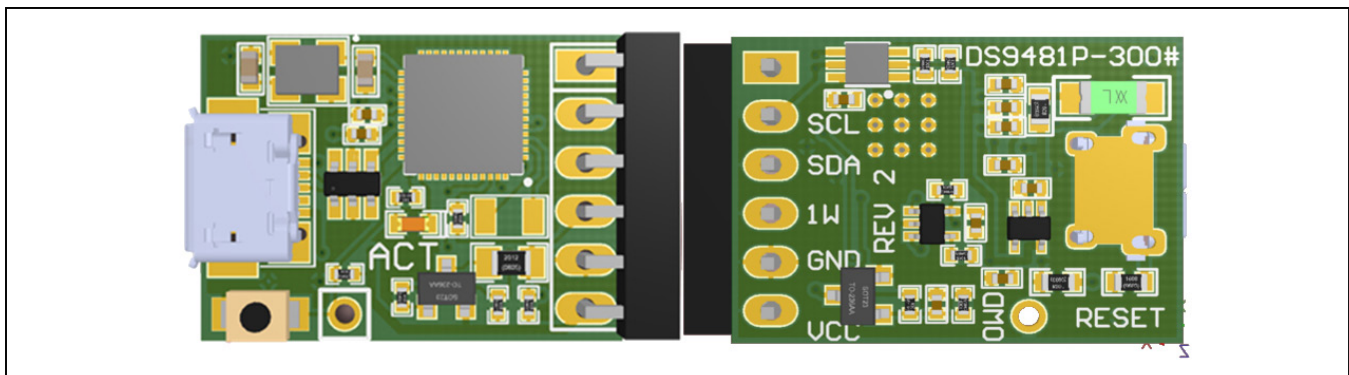

Figure 2. DS9481P-300# USB-to-1-Wire Adapter

1-Wire is a registered trademark of Maxim Integrated Products, Inc.

Windows is a registered trademark of Microsoft Corporation.



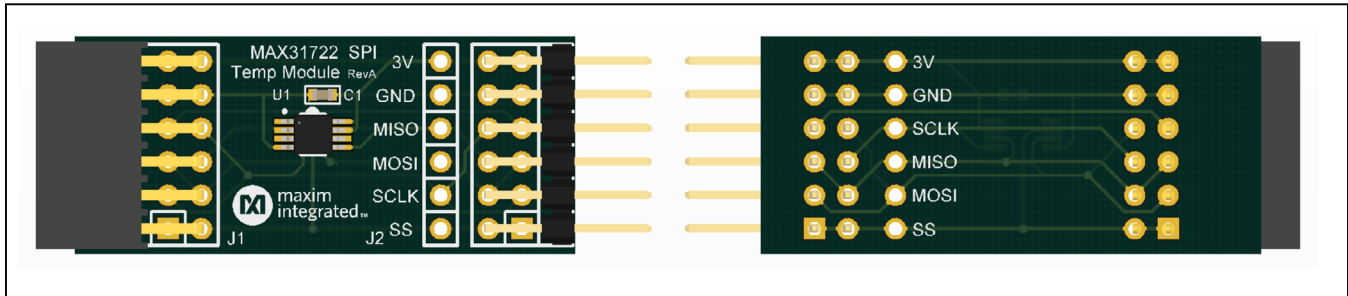

Figure 3. MAX31722 PMOD Board

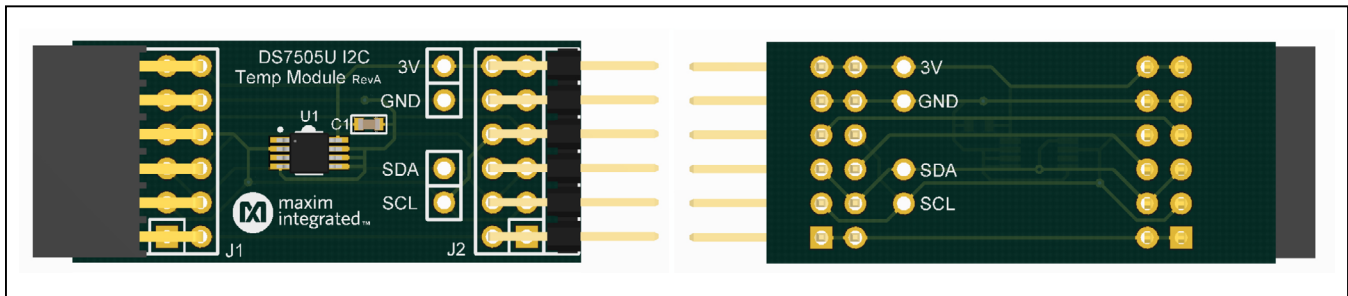

Figure 4. DS7505 PMOD Board

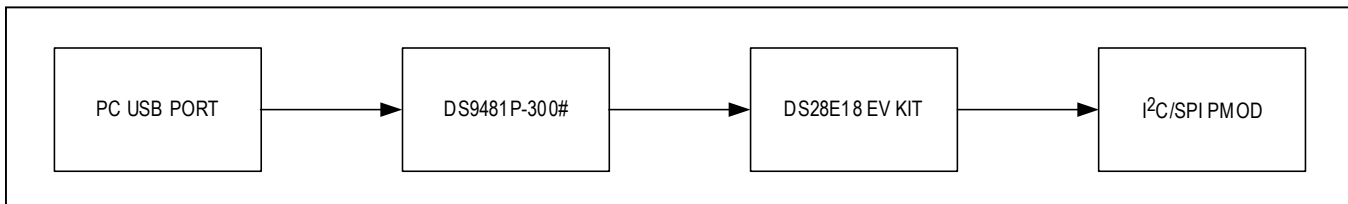

Figure 5. Typical Setup

DS28E18 EV Kit Files

FILE	DESCRIPTION
DS28E18 EV Kit	EV kit software

Quick Start

Required Equipment

- DS28E18 EV kit (included)
- DS9481P-300# USB-to-1-Wire adapter (included)
- PC with a Windows 10/8/7 (32-bit or 64-bit) operating system and a spare USB 2.0 or higher port
- 1-Wire drivers
- DS28E18 EV kit software

Note: In the following sections, software-related items are identified by **bolding**. Text in **bold** refers to items directly from the EV kit software. Text in **bold and underlined** refers to items from the Windows operating system.

Procedure

The EV kit is fully assembled and tested. Follow the steps below to verify board operation:

- 1) Install the 1-Wire drivers as shown in [Figure 7](#), [Figure 8](#), and [Figure 9](#).
- 2) Attach the DS9481P-300# adapter to the DS28E18 EV kit ([Figure 6](#)).
- 3) Obtain the latest version of the DS28E18 EV kit software.
- 4) Unzip and save the EV kit software to a known location.
- 5) Open the **DeviceDriver** folder.
- 6) Right-click on **install.bat** and then choose **Run as administrator** ([Figure 7](#)).
- 7) A command window opens with a prompt asking to install the device driver ([Figure 8](#)). Click **Install**.

- 8) Open the folder where the DS28E18 EV kit software was extracted and double-click the **Setup.exe** file.
- 9) Plug the USB cable to the DS9481P-300# adapter.
- 10) Insert the DS9481P-300# into a spare USB port on the PC.
- 11) The device will automatically search for and install the driver ([Figure 9](#)).
- 12) To start the evaluation software, ensure that the DS9481P-300# has been properly installed and the DS28E18 board and DS9481P-300# adapter are connected.

- Run the DS28E18 EV kit software: **Start** → **Programs** → **Maxim Integrated** → **DS28E18EV Kit**
- 13) If the DS9481P-300# is not detected or connected to the USB port, the software displays an error message ([Figure 11](#)). Close the program window, reconnect the DS9481P-300# adapter, and restart the program again.
 - 14) Once properly installed, the initial screen graphical user interface (GUI) should appear ([Figure 12](#)).

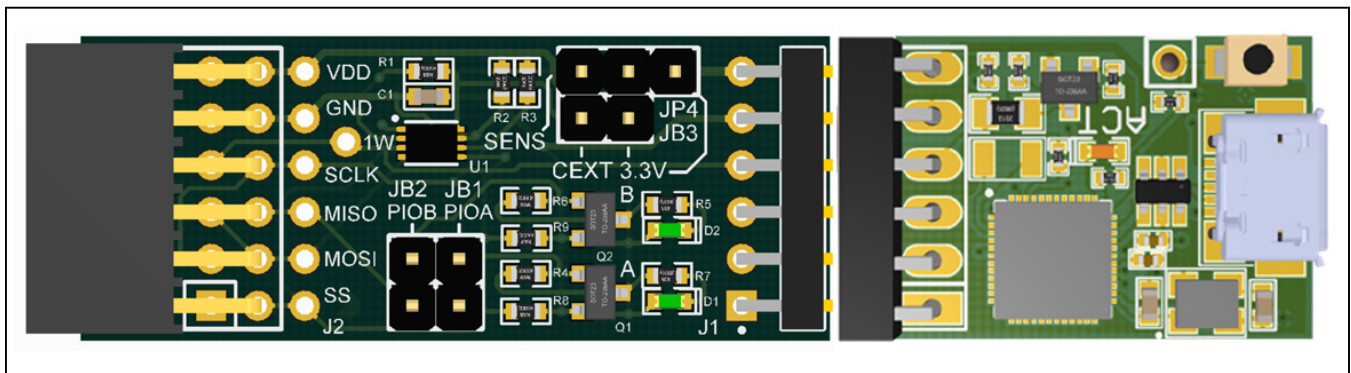

Figure 6. DS9481P-300 Attached with DS28E18 EV Kit Board

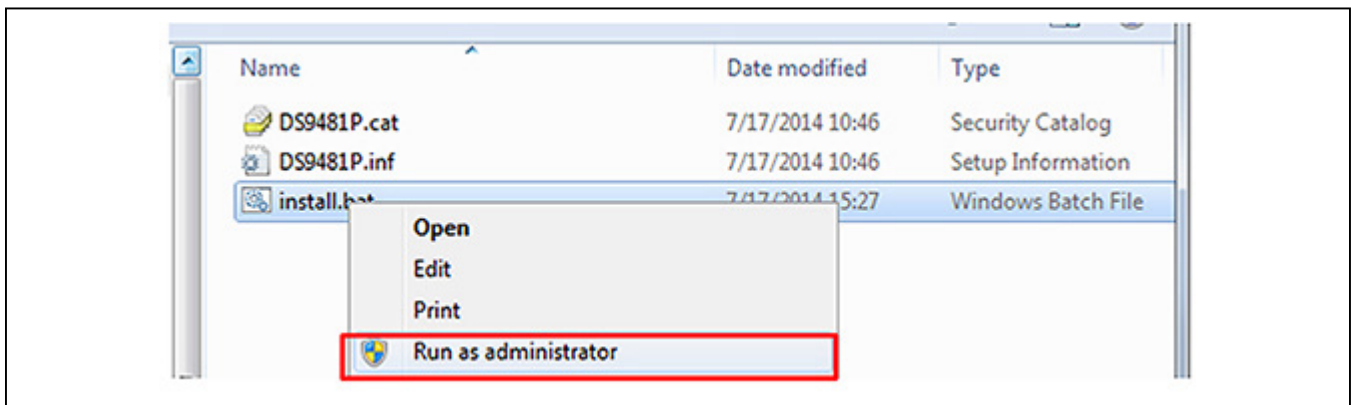

Figure 7. Device Driver Installation

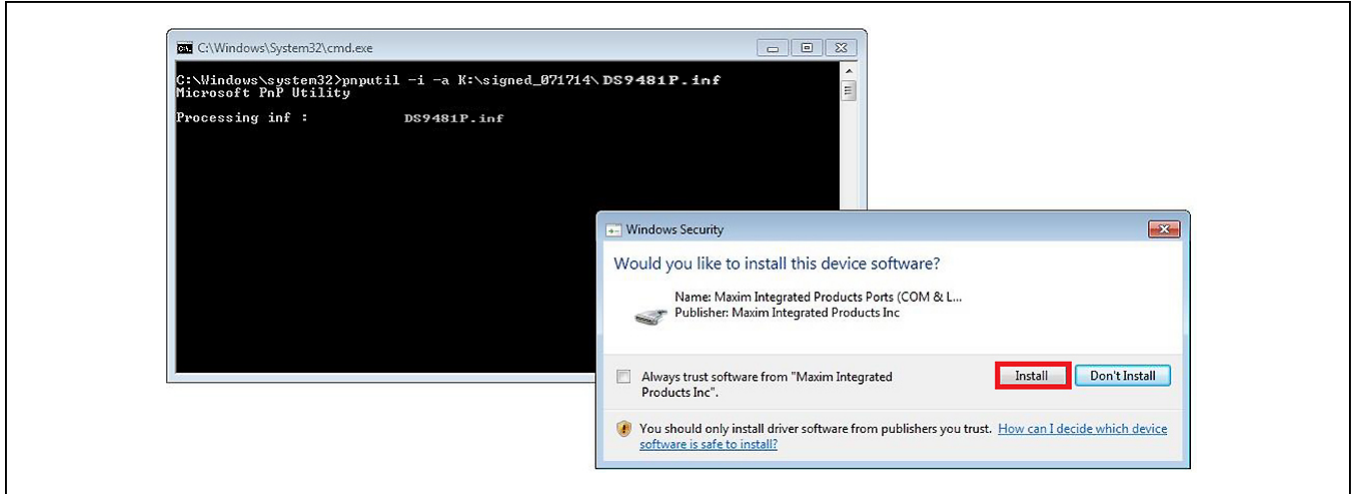

Figure 8. Device Driver (Install Device Software)

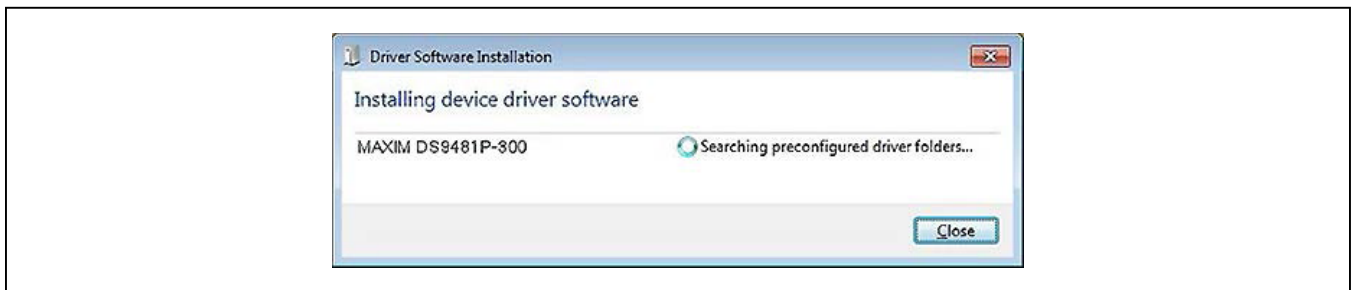

Figure 9. Device Driver Successfully Installed

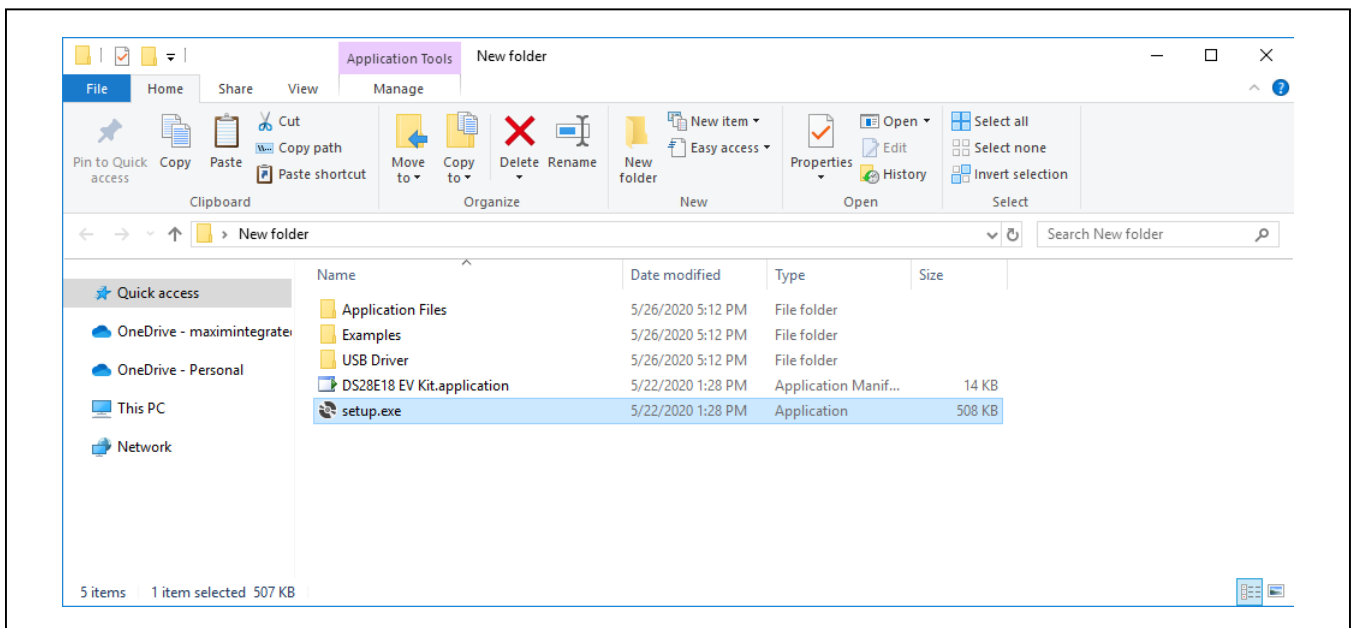

Figure 10. Opening the DS28E18 Evaluation Program Setup

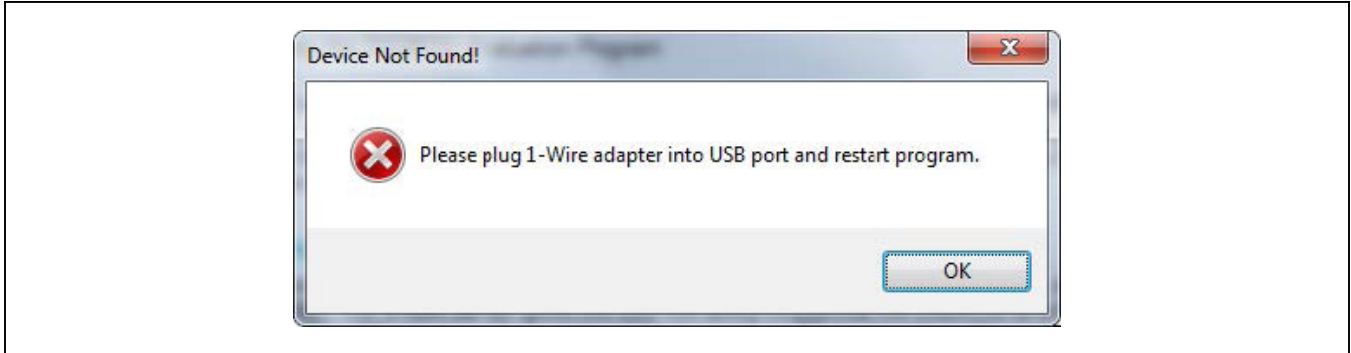

Figure 11. DS9481P-300# Error Message

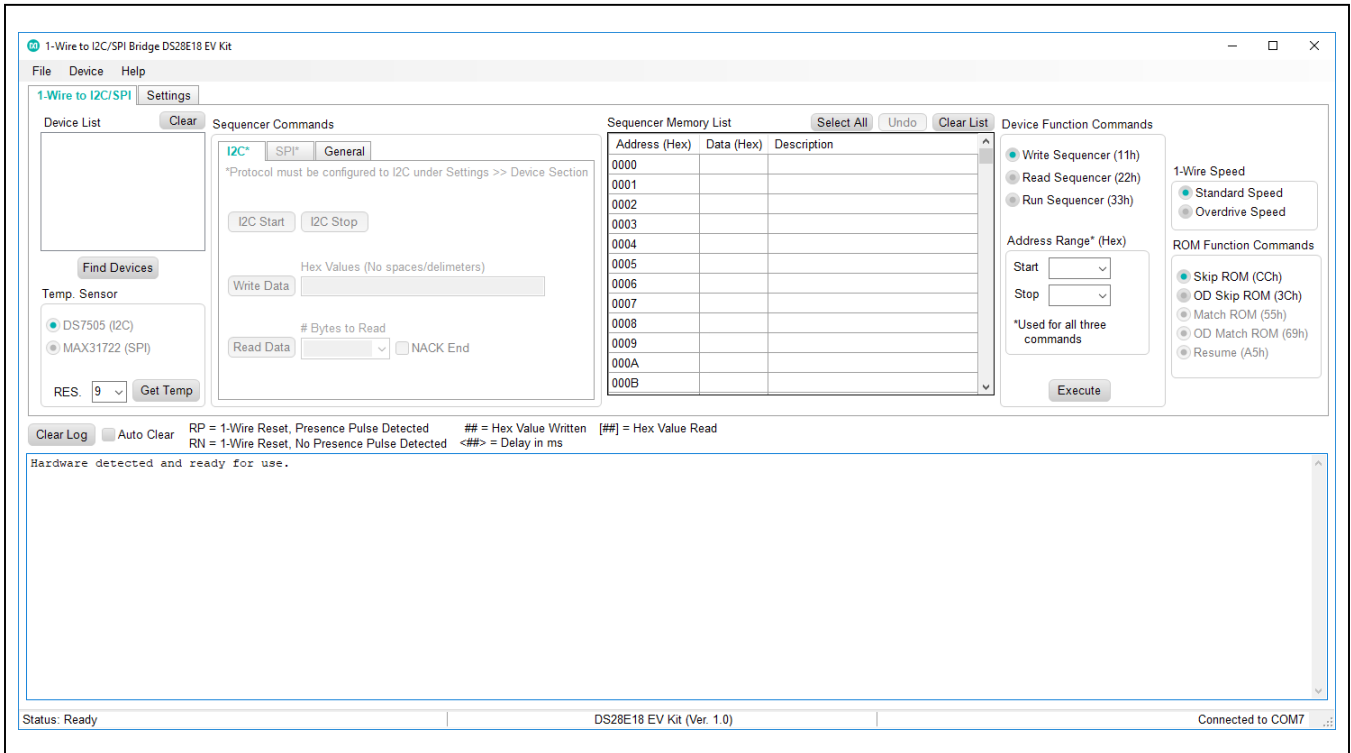

Figure 12. DS28E18 EV Kit Software Initial Screen GUI

Detailed Description of Software

The DS28E18 evaluation program user interface (Figure 12) has two tabs: **1-Wire to I2C/SPI** and **Settings**. The **1-Wire to I2C/SPI** tab is the main tool to evaluate specific functions of the DS28E18. The **Settings** tab (Figure 13) provides control over the device's general and GPIO configurations.

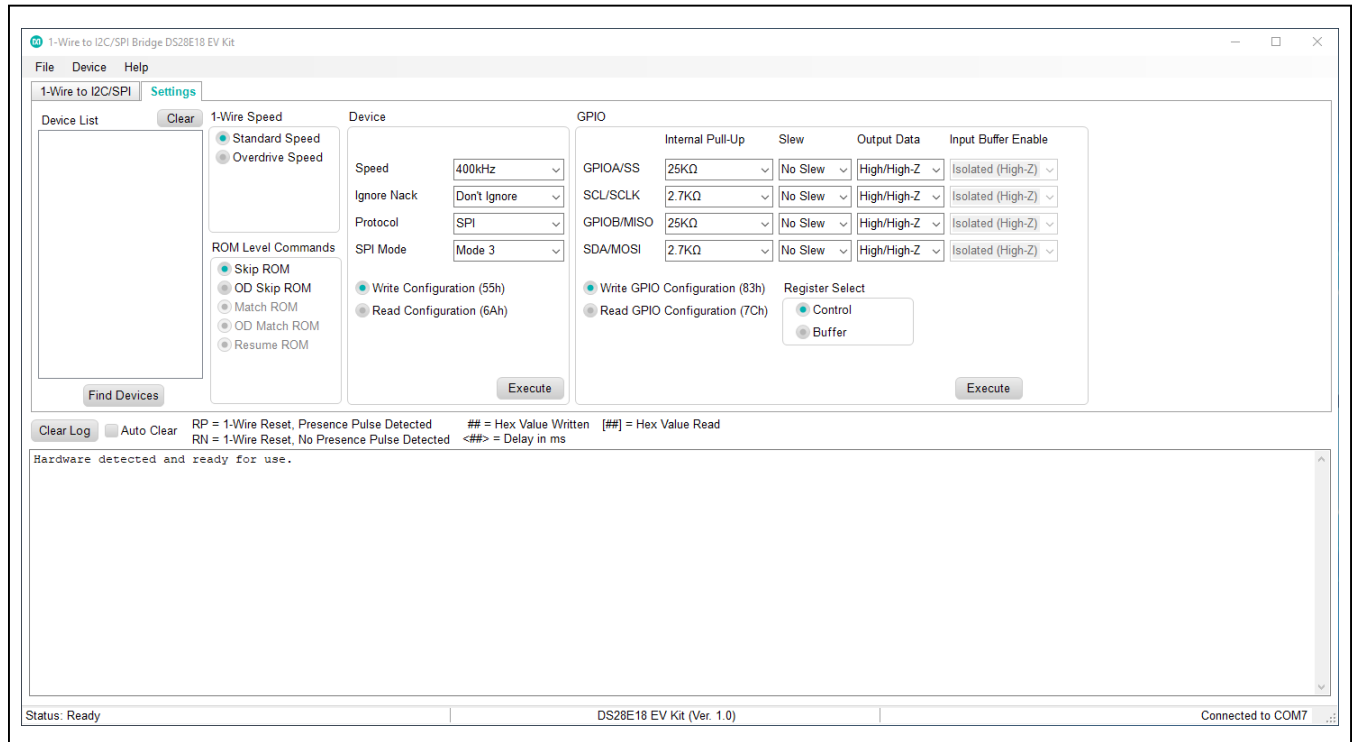

Figure 13. DS28E18 EV Kit Software, Settings Tab

1-Wire to I2C/SPI Tab

The DS28E18 EV kit board provides a peripheral module connector designed for attaching either an I²C or SPI slave. To help communicate with attached slave devices, the **1-Wire to I2C/SPI** tab provides the following controls: **Find Devices**, **Sequencer Commands**, **Sequencer Memory List**, **Device Function Commands**, and **Get Temp**. See [Table 1](#) for more details on each control.

Settings Tab

The **Settings** tab provides the necessary controls for configuring the devices' general and GPIO settings. See [Table 2](#) for more details on each control.

Table 1. 1-Wire to I²C/SPI Controls

ELEMENT NAME (TYPE)	DESCRIPTION
Find Devices (Action button)	Triggers the Search ROM command and powers up all discovered devices after adding them to the Device List box. See the log for a detailed flow of the power-up sequence.
Get Temp (Action button)	Example flow for getting temperature from either the DS7505 or MAX31722 peripheral module boards included with the kit using the DS28E18. Only available after clicking Find Devices . To select between modules, configure the device Protocol under the Settings tab. See the DS7505 or MAX31722 data sheet for product specific details and sequences.
Sequencer Commands (Action buttons)	Controls used in conjunction with the Sequencer Memory List to build I ² C/SPI sequences. Only available after clicking Find Devices . To avoid mixing sequences, only one tab can be used between I ² C and SPI controls. To select between I ² C and SPI controls, configure the device Protocol under the Settings tab.
Sequencer Memory List (Data Grid)	Table used in conjunction with the Sequencer Commands controls to build I ² C/SPI sequences. Each sequencer command populates and updates this table with its respective command structure recognized by the DS28E18. Data displayed in this list does not reflect the actual data found in the DS28E18 memory and is just a tool used to help manipulate data with the device function commands.
Device Function Commands (Action buttons)	Controls used in conjunction with the Sequencer Memory List to manipulate the DS28E18 memory. Click the Select All button, or manually enter the desired address in Address Range box, to specify the location in memory to Write to or Read/Run from. Select between three different device function commands: Write Sequencer (11h) - Writes the data from the highlighted address into the actual memory address. Read Sequencer (22h) - Reads the actual data that resides in memory address highlighted. Run Sequencer: (33h) - Runs the actual data that resides in memory address highlighted. Must click the Execute button to perform an action.

Table 2. Settings Controls

ELEMENT NAME	DESCRIPTION
Device	Used for writing or reading the DS28E18's general configuration. Select between the Device Function Command options to specify action. Customize the desired configuration with the available drop-down boxes (only available when Write Configuration (55h) is selected). Must click the Execute button to perform an action.
GPIO	Used for writing or reading the DS28E18's GPIO Control and Buffer configuration. Select between the Device Function Commands and register options to specify an action. Customize the desired configuration using the available drop-down boxes (only available when Write GPIO Configuration (83h) is selected). Must click the Execute button to perform an action.

Detailed Description of Hardware

For more information on jumper configurations, see [Table 3](#).

Table 3. Jumper Settings

JUMPER	SETTING	DETAILS
JB1	Open	Enable LED, D1 toggle control through GPIOA
	Closed	Disable LED, D1 toggle control
JB2	Open	Enable LED, D2 toggle control through GPIOB
	Closed	Disable LED, D2 toggle control
JB3	Open	DS28E18 powered through DS9481P-300 3.3V supply
	Closed	DS28E18 powered parasitically through DS9481P-300 1-Wire
JP4	Open	No power being supplied through 12-pin female connector
	3.3V and VDD	3.3V power being supplied through 12-pin female connector
	SENS and VDD	SENS_VDD power being supplied through 12-pin female connector

Ordering Information

PART	TYPE
DS28E18EVKIT#	EV system

#Denotes RoHS compliant.

Revision History

REVISION NUMBER	REVISION DATE	DESCRIPTION	PAGES CHANGED
0	6/20	Initial release	—

For pricing, delivery, and ordering information, please visit Maxim Integrated's online storefront at <https://www.maximintegrated.com/en/storefront/storefront.html>.

Maxim Integrated cannot assume responsibility for use of any circuitry other than circuitry entirely embodied in a Maxim Integrated product. No circuit patent licenses are implied. Maxim Integrated reserves the right to change the circuitry and specifications without notice at any time.