

SHERPA

Power Base F

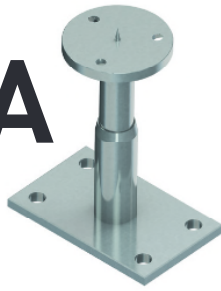

MONTAGEANLEITUNG

Der SHERPA Power Base mit Zentrierspitze und Schrägverschraubung, ermöglicht eine einfache und präzise Montage. Der Anschluss ist für Stützen aus Vollholz und Brettschichtholz geeignet. Die Schrauben werden unsichtbar und witterungsgeschützt eingebracht.

ASSEMBLY INSTRUCTIONS

The SHERPA Power Base with a centre point and angular screw connection facilitates easy and precise assembly. The connection is suitable for supports made of solid wood and glued-laminated timber. The screws are placed such that they are invisible and weatherproof.



STUFE 1

KOPFPLATTE SICHTBAR / UNSICHTBAR

Die Kopfplatte soll stirnseitig zentriert und mit drei SHERPA Spezialschrauben 8 x 160 oder 8 x 180 mm in einem Winkel von ca. 25° befestigt werden. Den konstruktiven Holzschutz verbessert das Versenken der Kopfplatte in der Stütze. (t= 20 mm / Ø 96 mm).

STEP 1

END PLATE VISIBLE / INVISIBLE

The end plate should be centered on the face and secured with three SHERPA special screws 8 x 160 or 8 x 180 mm at a 25° angle. Retracting the end plate into the support improves the protection of the structure of the wood (t= 20 mm / Ø 96 mm).

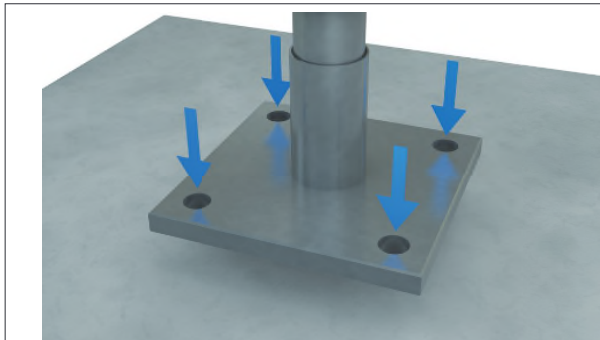

STUFE 2

ZUSAMMENBAU UND VERANKERUNGEN

Die Verbindung zwischen Kopfplatte und Unterbau erfolgt mit einem Flanschring und drei Inbusschrauben. Ein Zerlegen ist nicht zwingend erforderlich aber optional möglich. Die Sockelplatte wird wahlweise mit vier Metallspreizdübeln oder Betonschrauben verankert.

STEP 2

ASSEMBLY AND ANCHORING

The connection between head plate and foundation is carried out via a flange ring and three socket screws. Disassembly is possible but not compulsory. The vibrating plate compactor is anchored either via four steel expansion anchors or via concrete bolts.

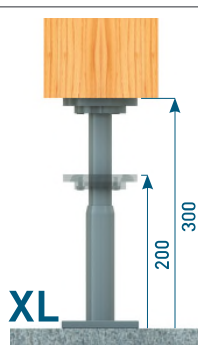
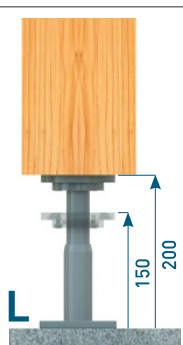
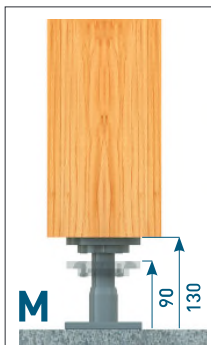

STUFE 3

STUFENLOSE HÖHENEINSTELLUNG

Fertigungstoleranzen und Setzungen im Gebäude können auch noch unter Last ausgeglichen werden (Gabelschlüssel 26 mm). Mögliche Höheneinstellungen sind:

M 125 F.....	90 - 130 mm
L 125 F.....	150 - 200 mm
XL 95 F.....	200 - 300 mm

STEP 3

INFINITELY VARIABLE HEIGHT SETTING

Manufacturing tolerances and settlings in the building can be adjusted even when under load (open-end wrench 26 mm). Possible height settings are:

M 125 F.....	90 - 130 mm
L 125 F.....	150 - 200 mm
XL 95 F.....	200 - 300 mm

Bezeichnung	Höheneinstellung	Holzschrauben	Min. Holz-Dimension	Kopfplatte	Sockelplatte	Betondübel	Tragfähigkeit R _{1,d}
Name	Height setting	Wood screws	Min. wood dimension	End plate	Base plate	Concrete Dowel	Load capacity R _{1,d}
Power Base M 125 F	90 - 130 mm	3 Stk. 8 x 160 mm	120 x 120 / Ø 120 mm	Ø 96 mm	100 x 160 mm	4 Stk. / pcs.	max. 125 kN
		3 Stk. 8 x 180 mm	140 x 140 / Ø 140 mm				
Power Base L 125 F	150 - 200 mm	3 Stk. 8 x 160 mm	120 x 120 / Ø 120 mm	Ø 96 mm	100 x 160 mm	4 Stk. / pcs.	max. 125 kN
		3 Stk. 8 x 180 mm	140 x 140 / Ø 140 mm				
Power Base XL 95 F	200 - 300 mm	3 Stk. 8 x 160 mm	120 x 120 / Ø 120 mm	Ø 96 mm	100 x 160 mm	4 Stk. / pcs.	max. 95 kN
		3 Stk. 8 x 180 mm	140 x 140 / Ø 140 mm				

THE LEADING TECHNOLOGY IN STANDARDIZED TIMBER CONNECTION SYSTEMS

SHERPA Connection Systems GmbH
+43 (0) 3127 / 41 983
support@sherpa-connector.com
www.sherpa-connector.com

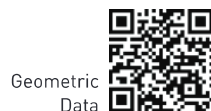

SHERPA

SHERPA

Power Base F

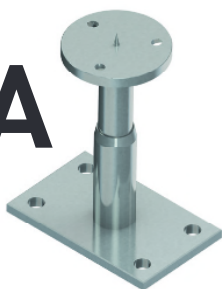

ISTRUZIONI PER IL MONTAGGIO

Lo SHERPA Power Base con puntale di centraggio e fissaggio con viti inclinate permette il montaggio facile e preciso. L'attacco è studiato per montanti in legno massiccio oppure lamellare. Le viti non sono visibili e risultano protette dagli agenti atmosferici.

NOTICE DE MONTAGE

La Power Base SHERPA avec pointe d'alignement et vissage en biais permet un montage simple et précis. Le raccord convient pour des supports en bois plein et lamellé. Les vis restent invisibles et sont protégées des intempéries.



PASSO 1

PIASTRA IN TESTA A VISTA / NASCOSTA

La piastra in testa deve essere fissata in posizione centrata per mezzo delle tre viti speciali SHERPA 8 x 160 e 8 x 180 mm inclinate a circa 25° tra di loro. La protezione del legno migliora l'inserimento della piastra in testa nel montante (t = 20 mm / Ø 96 mm).

ÉTAPE 1

PLAQUE SUPÉRIEURE VISIBLE / INVISIBLE

La plaque sup. doit être fixée centralement, côté frontal, avec trois vis spéc. SHERPA de 8 x 160 ou 8 x 180 mm dans un angle d'env. 25°. Pour protéger la construction en bois, enfoncer la plaque supérieure dans le support (t = 20 mm / Ø 96 mm).

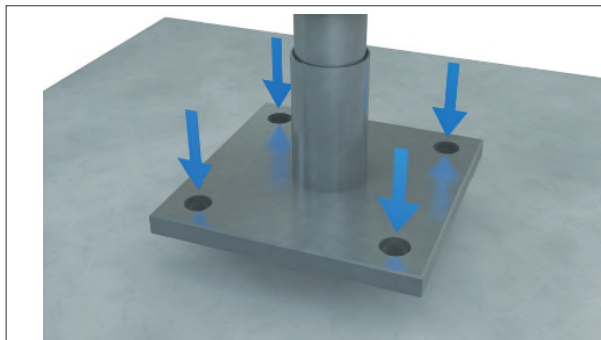

PASSO 2

MONTAGGIO E ANCORAGGIO

La connessione tra piastra di testa e sottostruttura avviene tramite anello flangiato e tre brugole. La scomposizione è possibile ma non obbligatoria. La piastra dello zoccolo sarà ancorata o tramite quattro tasselli metallici ad espansione o tramite viti per calcestruzzo.

ÉTAPE 2

ASSEMBLAGE ET ANCRAGE

La jonction entre la plaque supérieure et le bâti s'effectue à l'aide d'une bride et de trois vis à six pans. Un démontage n'est pas une obligation mais une option. La plaque d'embase se fixe au choix à l'aide de quatre chevilles métalliques à expansion ou vis à béton.

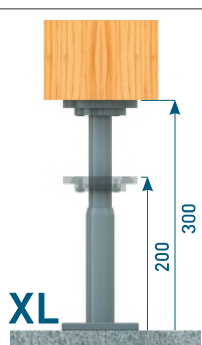
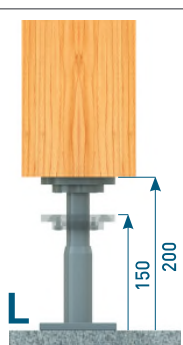
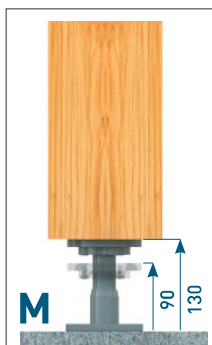

PASSO 3

REGOLAZIONE CONTINUA DELL'ALTEZZA

Agendo sulla ghiera di regolazione (chiave fissa da 26 mm) si possono assorbire le tolleranze e l'assestamento di edifici.

Possibili intervalli di regolazione: M 125 F..... 90 - 130 mm
L 125 F..... 150 - 200 mm
XL 95 F..... 200 - 300 mm

ÉTAPE 3

INFINITELY VARIABLE HEIGHT SETTING

Tolérances de fabrication et tassements dans le bâtiment peuvent être aussi compensées sous charge (clé à fourche 26 mm).

Réglages possibles de la hauteur: M 125 F..... 90 - 130 mm
L 125 F..... 150 - 200 mm
XL 95 F..... 200 - 300 mm

Definizione	Int. di regolazione	Viti per legno	Sezione minima legno	Piastra di testa	Piastra ancoraggio	Viti per calcestruzzo	Carico massimo R _{1,d}
Désignation	Réglage hauteur	Vis à bois	Dimension min. bois	Plaqu. sup	Plaque socle	Chev. béton	Cap. portante R _{1,d}
Power Base M 125 F	90 - 130 mm	3 unità. 8x 160 mm	120 x 120 / Ø 120 mm	Ø 96 mm	100 x 160 mm	4 unità. / pces.	max. 125 kN
		3 pces 8 x 180 mm	140 x 140 / Ø 140 mm				
Power Base L 125 F	150 - 200 mm	3 unità. 8x 160 mm	120 x 120 / Ø 120 mm	Ø 96 mm	100 x 160 mm	4 unità. / pces.	max. 125 kN
		3 pces 8 x 180 mm	140 x 140 / Ø 140 mm				
Power Base XL 95 F	200 - 300 mm	3 unità. 8x 160 mm	120 x 120 / Ø 120 mm	Ø 96 mm	100 x 160 mm	4 unità. / pces.	max. 95 kN
		3 pces 8 x 180 mm	140 x 140 / Ø 140 mm				

THE LEADING TECHNOLOGY IN STANDARDIZED TIMBER CONNECTION SYSTEMS

SHERPA Connection Systems GmbH
+43 (0) 3127 / 41 983
support@sherpa-connector.com
www.sherpa-connector.com

Geometric
Data



Manual



SHERPA