

REVISIONS			
REV.	DESCRIPTION	DATE	APPROVED
1		29/03/2010	
2	DIMS REVISED, SPOTS ADDED	23/02/2011	MTC

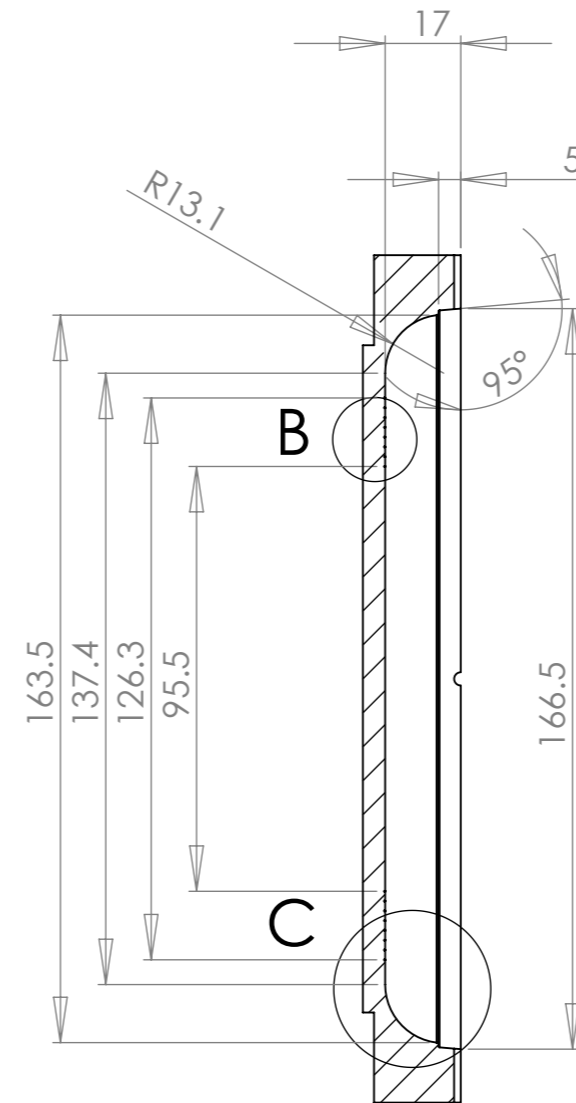

SECTION A-A

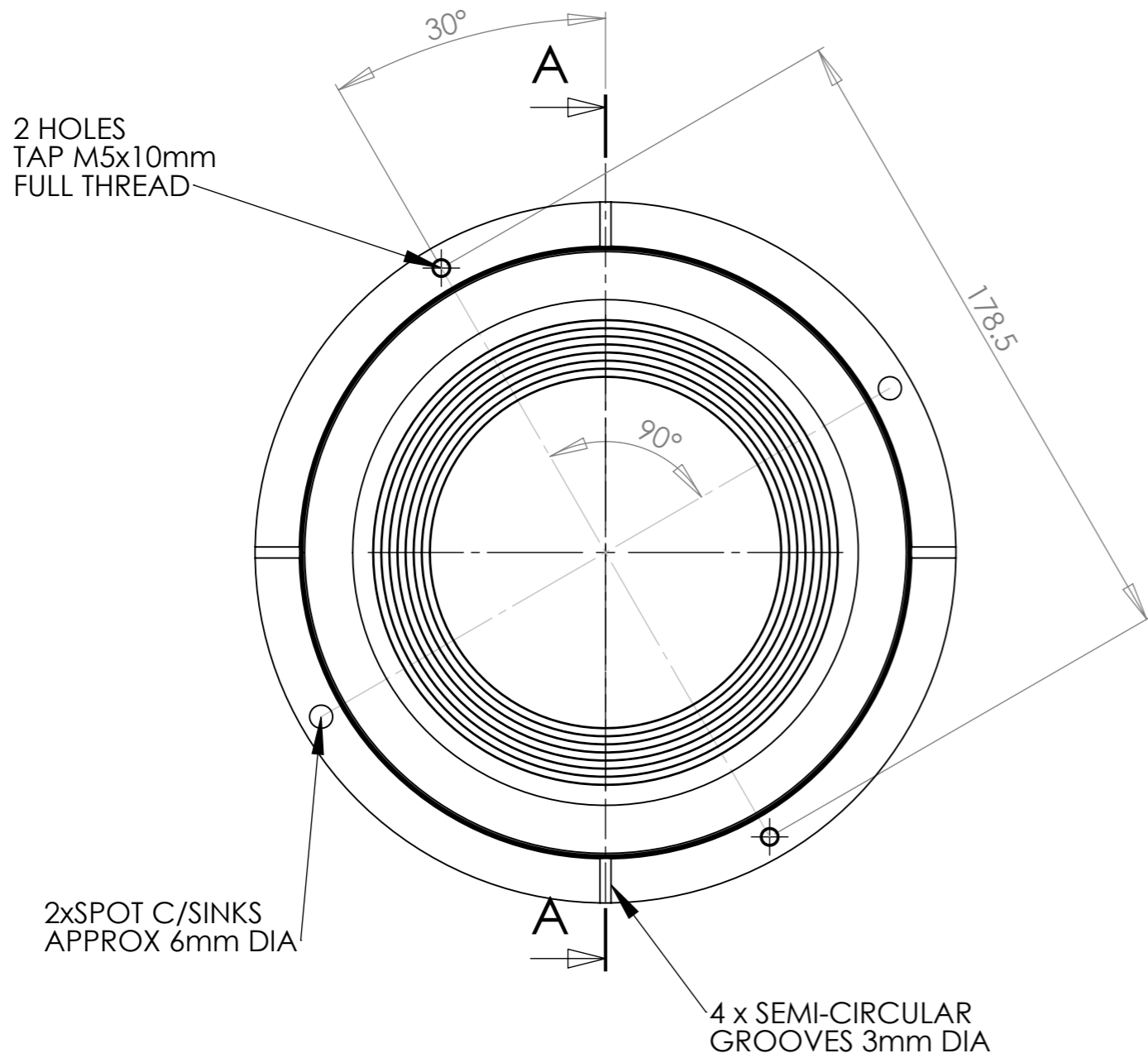
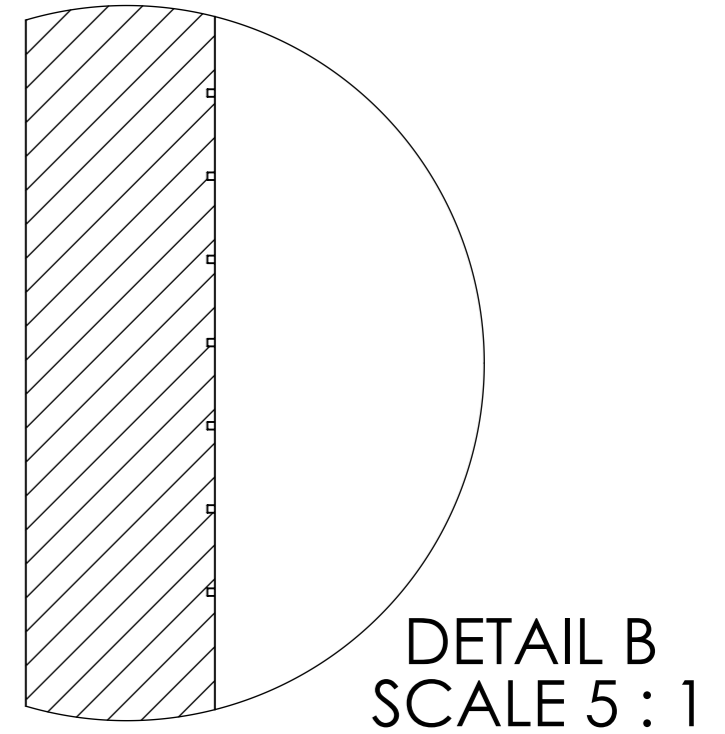

8 ANNULAR GROOVES APPROX
0.2mm WIDE, 0.2mm DEEP.
USE TOOLTIP TO FORM

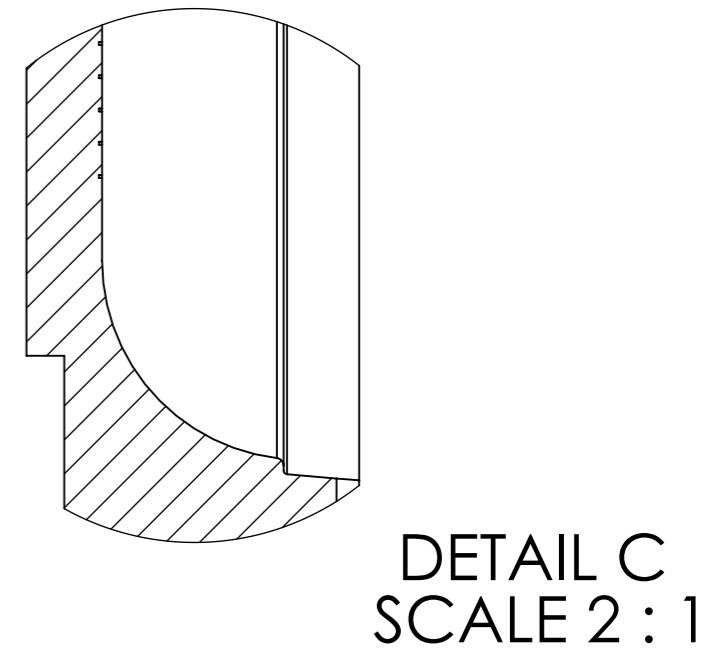

2xSPOT C/SINKS
APPROX 6mm DIA

		DO NOT SCALE DRAWING	DEBUR AND BREAK SHARP EDGES
Drawn:	MTC	Date:	27/08/2010
Checked:	MTC	Date:	27/08/2010
Issue No:	2	Part No: R30M01-01	
Material:	ALUMINIUM	Description: MOULD TOOL-FRISBE-FEMALE	
Finish:	NATURAL		
Tolerances:	Metric +/-0.5mm Angular +/-0.5 Deg Imperial Dec +/-0.010", Frac +/-1/64"		