



Model Number

NBN3-F31K2-E8-B13-S

Features

- Direct mounting on standard actuators
- Weatherproof housing for outdoor applications
- Temperature range -40 ... 167 °F (-40 °C to 75 °C)
- LED for power on
- LEDs for switching state of sensor and solenoid valve
- Plug-in terminals

Application

Note

The connections to this sensor are sealed with stopping plugs to protect against dirt and moisture. If not all of the connections are used in your application, then seal the remaining stopping plugs on the sensor permanently or check during initial installation and when performing regular maintenance work that the stopping plugs are secure and impermeable. If necessary, tighten the stopping plugs to a torque of 1 Nm.

Accessories

BT65-F31K2-RG-EN

Activator for F31K2 series

BT65A

Activator for F31 series

BT65X

Activator for F31 series

Technical Data

General specifications

Switching function	2 x normally open (NO)
Output type	PNP
Rated operating distance	s_n 2.5 mm
Installation	for non-flush mounting
Output polarity	DC
Assured operating distance	s_a 0 ... 2.05 mm
Output type	4-wire

Nominal ratings

Operating voltage	U_B	10 ... 30 V
Switching frequency	f	0 ... 100 Hz
Hysteresis	H	typ. 5 %
Reverse polarity protection		all connections
Short-circuit protection		pulsing
Voltage drop	U_d	≤ 3 V
Operating current	I_L	0 ... 100 mA
Off-state current	I_r	0 ... 0.5 mA typ. 0.1 μA
No-load supply current	I_0	≤ 25 mA
Operating voltage indicator		LED, green
Switching state indicator		LED, yellow
Valve status indicator		LED, yellow

Functional safety related parameters

MTTF _d	490 a
Mission Time (T _M)	20 a
Diagnostic Coverage (DC)	0 %

Ambient conditions

Ambient temperature	-40 ... 75 °C (-40 ... 167 °F)
Storage temperature	-40 ... 85 °C (-40 ... 185 °F)

Mechanical specifications

Connection (system side)	screw terminal, M20 x 1.5 cable gland
Core cross-section (system side)	1.5/2.5 mm ² flexible/rigid
Housing material	rugged, translucent polycarbonate (PC) optimised for outdoor use
Housing base	PC
Degree of protection	IP66 / IP67 / IP69K
Tightening torque, housing screws	≤ 2 Nm
Tightening torque, cable gland	≤ 4 Nm
Tightening torque, stopping plug	1 Nm

Compliance with standards and directives

Standard conformity	
Standards	EN 60947-5-2:2007 IEC 60947-5-2:2007 VDI / VDE 3845

Approvals and certificates

EAC conformity	TR CU 020/2011
----------------	----------------

Dimensions

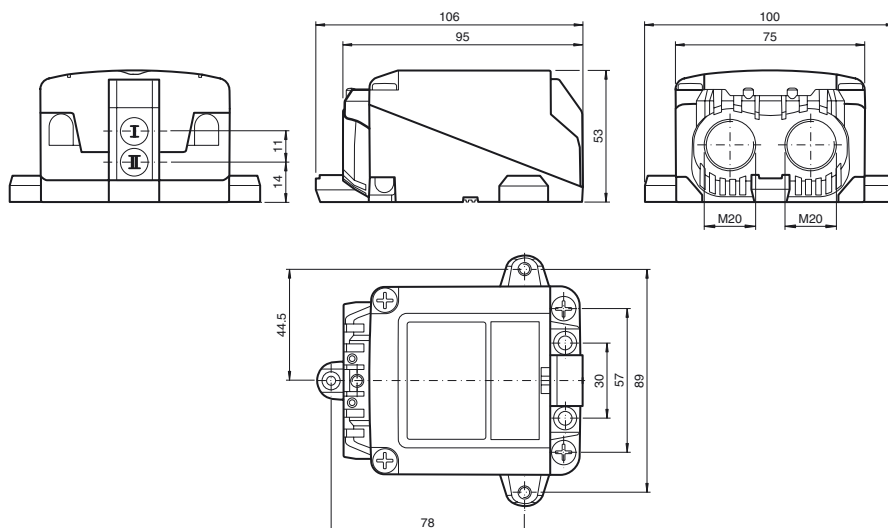

Electrical Connection

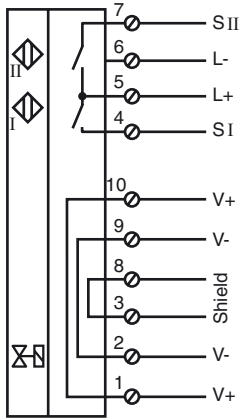

Release date: 2017-02-22 16:44 Date of issue: 2017-02-22 235086_eng.xml