

VARTA
 CR1/2AA
 3V Lithium
 MADE IN GERMANY
 MMY

+ + +

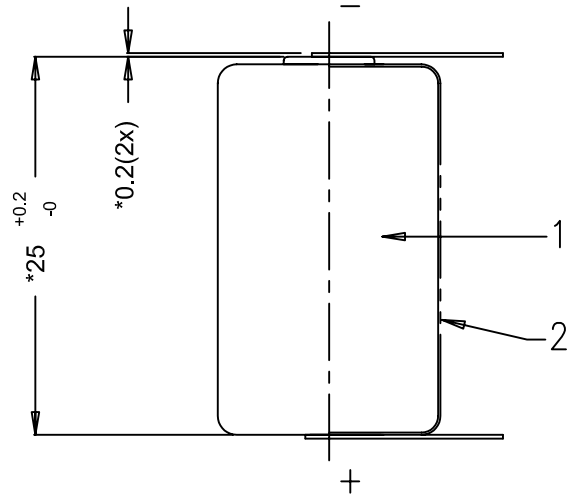

VARTA

Warning:
 Risk of fire,
 explosion or burns.
 Do not recharge,
 disassemble, crush,
 heat above 212°F
 (100°C) or incinerate.

+ + +

Monthly code
 eg. March 2008 = "0308"

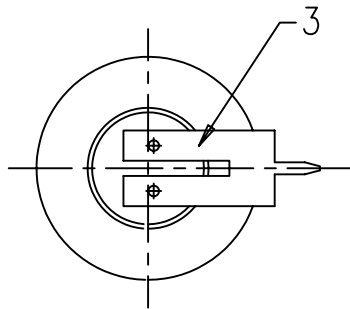

Note : 1) * Dimensions for reference only.
 2) Use UL approved green shrink sleeve

No	AO No	Revisions	Date	Name
1	R124/08	To add in printed sleeve the crossed-out wheeled bin symbol	2008-04-08	Ratna
0		Refer to # 009799	1999-08-03	Tatang

Projection:		Material: Refer to part list no: 071809		Description: CR 1/2 AA PCB battery with shrink sleeve & solder tags		
Dimensions in mm		Prepared & Checked	Verified & Approved	Dwg. No:	071809	4 0 1
Tolerance: As specified		1999-08-03	Tatang	VKB Order No:	06127 701 301	
Scale: 2 : 1						

