

RoHS compliant

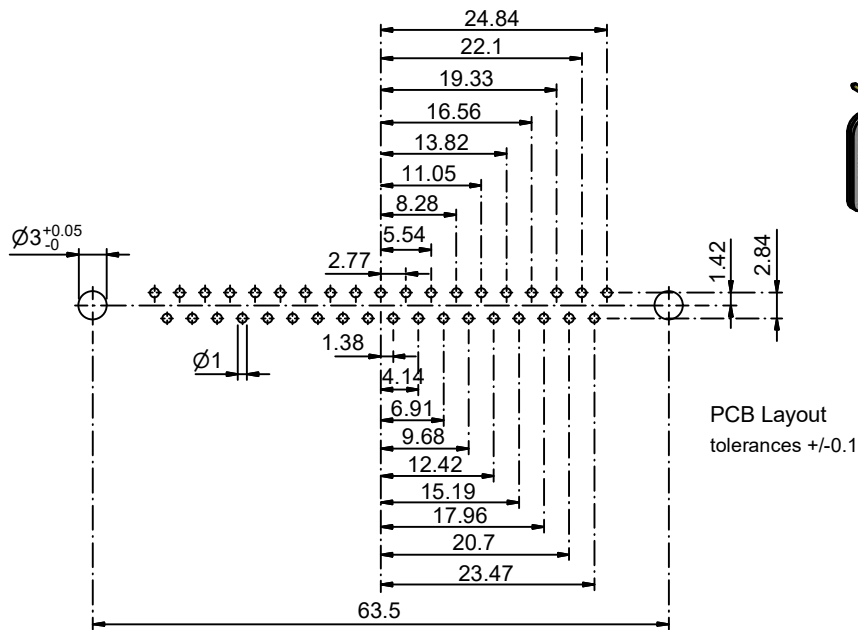
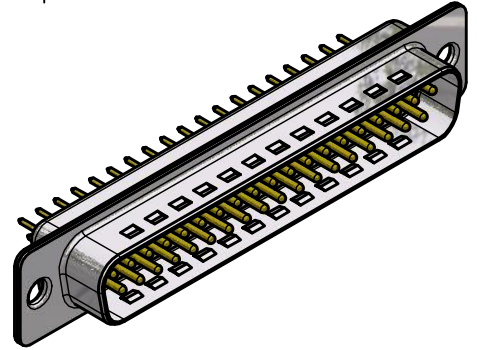
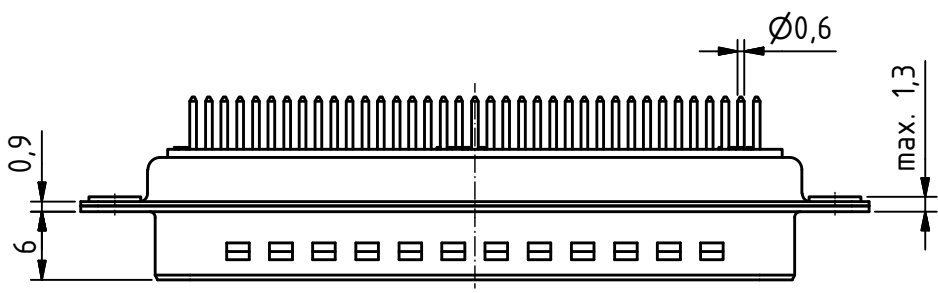
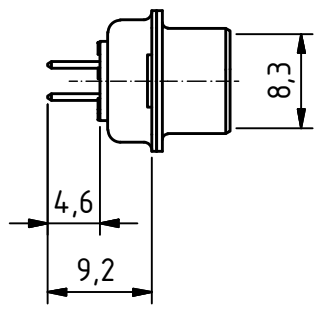
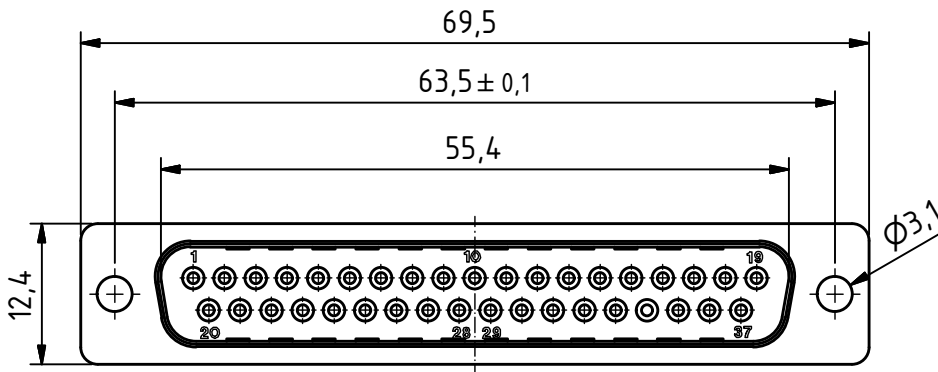

PCB Layout tolerances +/-0.1

Product is suitable for Wave Solder Process

General tolerances (Delttron standard)	
size in mm	
> 0.5 up to 3	±0.1
> 3 up to 6	±0.2
> 6 up to 30	±0.2
> 30 up to 120	±0.3
tolerances	
	±0.3

MATERIALS

- Insulator: Thermoplastic UL 94-V-0 white
- Contact: Machined / Copper alloy
- Contact finish: Quality class 2
- Shell: steel tin plated

CHARAKTERISTICS

- Working voltage: 125V
- Current rating: 7.5A
- Contact resistance: max. 10mΩ - DIN41652
- Insulation resistance: >5GΩ
- Temperature range: -55° to +125°C

	All dimensions in mm	Rev.	Rev.	Rev.	DE001299		
		Rev.	Rev.	Rev.	part no.		
DTS37PY/2				1.5:1 scale	drawn	27.10.2009	nf
					checked		
					approved		
				Industrie Neuhof 8c CH-3422 Kirchberg www.d-sub.swiss		K050035 drawing no.	