

# For reference only

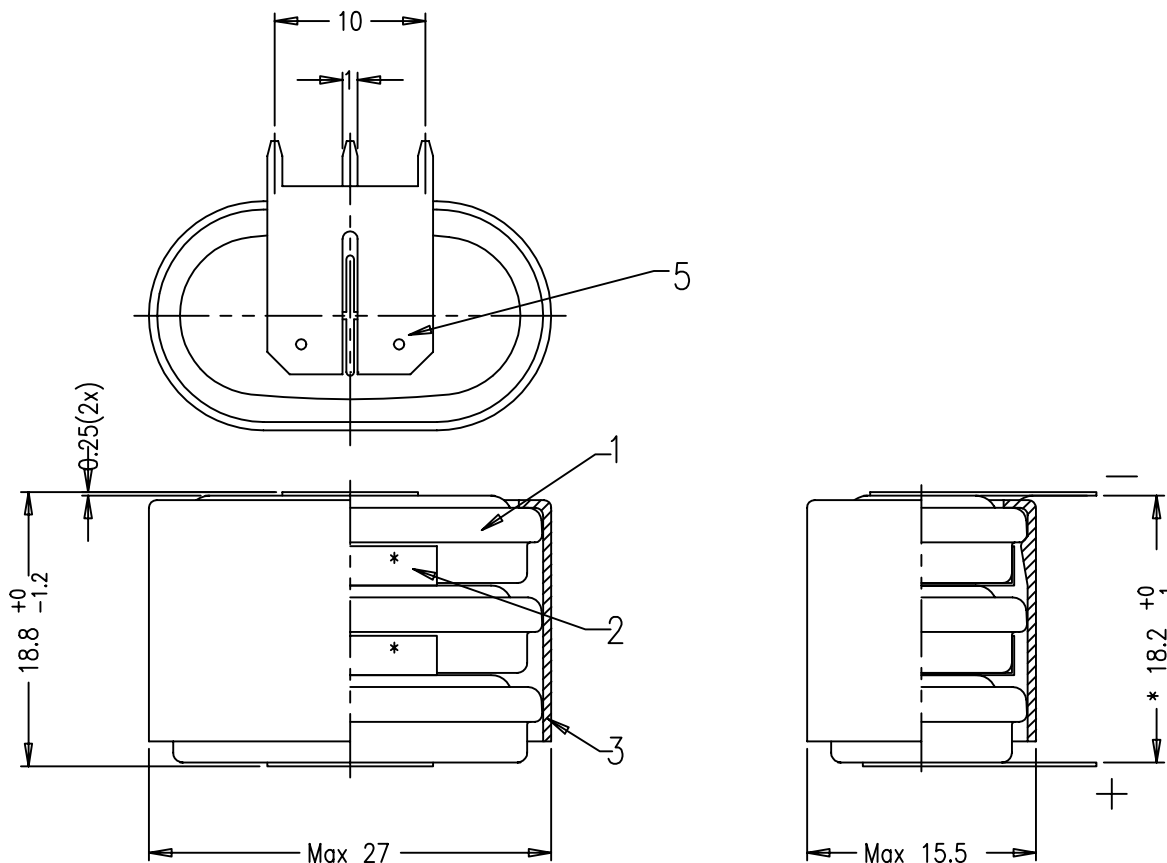

Printing is on this side of the casing

- Note:
- 1) No welding onto the groove
  - 2) For typical PCB-application we recommend to use VARTA-Mempac batteries
  - 3) \* For reference only

Approximate weight of battery : 18.4g

No.	Alterations:	Date:	Name:	Dimensions in mm	Material:
				Tolerance: DIN 7168 Medium	Refer to part list no: 070955
				Projection:	
				Scale: 2 : 1	Description:  3/V150H battery with snap-on plastic casing & solder tags
				Date: Name:	
				Prepared: 1997-10-24 C.Y.LEE	
				Approved: 2000-	
RIGHTS RESERVED TO MAKE TECHNICAL CHANGES, AS A RESULT OF FURTHER DEVELOPMENT, WITHOUT NOTICE . THIS DRAWING IS THE PROPERTY OF VARTA BATTERIES PTE LTD AND MUST NOT BE COPIED OR DISCLOSED TO A THIRD PARTY WITHOUT THE WRITTEN CONSENT OF VARTA BATTERIES PTE LTD.					Dwg. No: 070955
					VKB Order No: 55615 603 059
					Orig No: