

# II5321

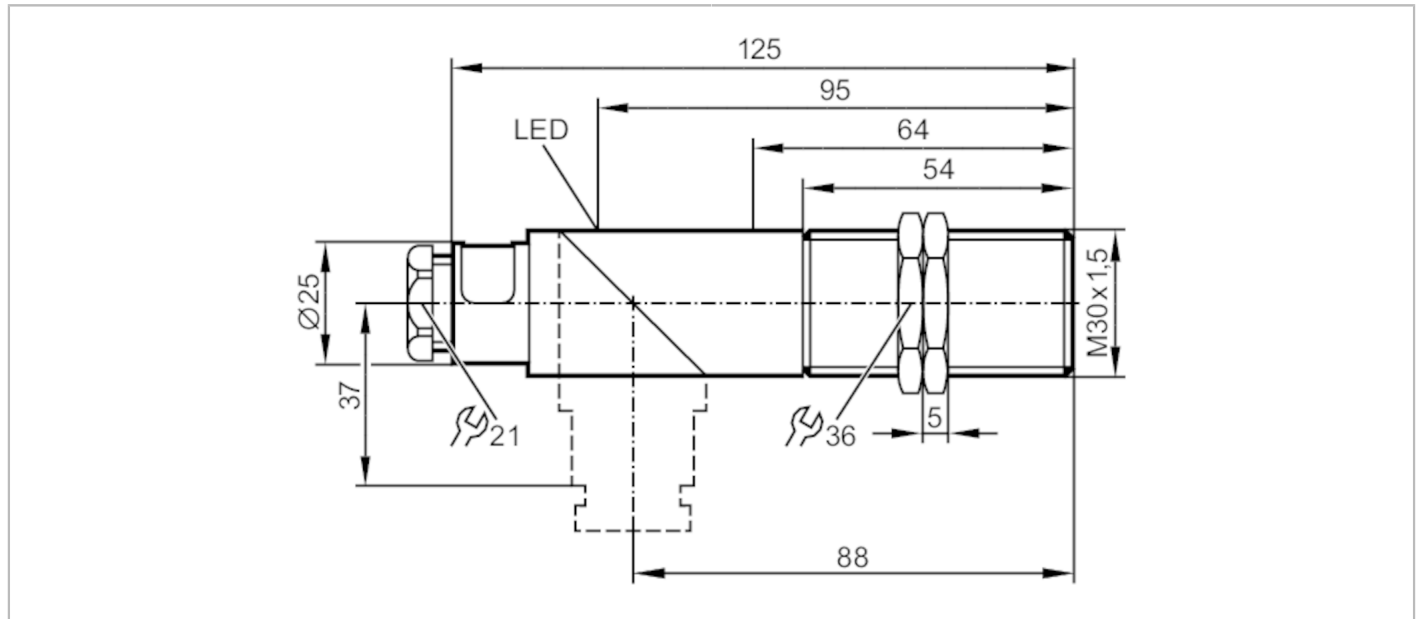

## Inductive sensor

IIE2015-FRKG



Product characteristics	
Electrical design	PNP/NPN
Output function	normally open / normally closed; (selectable)
Sensing range [mm]	15
Housing	threaded type
Dimensions [mm]	M30 x 1.5
Electrical data	
Operating voltage [V]	10...55 DC
Protection class	II
Reverse polarity protection	yes
Outputs	
Electrical design	PNP/NPN
Output function	normally open / normally closed; (selectable)
Max. voltage drop switching output DC [V]	4.6
Minimum load current [mA]	4
Max. leakage current [mA]	1
Permanent current rating of switching output DC [mA]	400
Switching frequency DC [Hz]	200
Short-circuit protection	yes
Type of short-circuit protection	pulsed
Overload protection	yes

# II5321



## Inductive sensor

IIE2015-FRKG

Detection zone		
Sensing range	[mm]	15
Real sensing range Sr	[mm]	15 ± 10 %
Operating distance	[mm]	0...12.1
Accuracy / deviations		
Hysteresis	[% of Sr]	1...15
Switch point drift	[% of Sr]	-10...10
Operating conditions		
Ambient temperature	[°C]	-25...80
Protection		IP 65
Tests / approvals		
EMC	EN 60947-5-2	
	EN 55011	class B
MTTF	[years]	1699
Mechanical data		
Weight	[g]	116
Housing		threaded type
Mounting		non-flush mountable
Dimensions	[mm]	M30 x 1.5
Thread designation		M30 x 1.5
Materials		PBT; end cap: PC
Displays / operating elements		
Display	switching status	1 x LED, yellow
Accessories		
Accessories (supplied)		lock nuts: 2
Remarks		
Pack quantity		1 pcs.

# II5321



## Inductive sensor

IIE2015-FRKG

### Electrical connection

terminals: ...2.5 mm<sup>2</sup>; Cable sheath: Ø 7...13 mm; Cable gland: M20 X 1.5

### Connection

