

Micrometer

Move to other products

- 1 SPC
- 2 Caliper
- 3 Depth gage
- 4 Height gage
- Micrometer
- 6 Inside micrometer
- 7 Micrometer head
- 8 Indicator
- 9 Test indicator
- 10 Gage head
- 11 Gauge Block
- 12 Reference gage
- 13 Surface plate
- 14 Miscellaneous
- 15 Linear scale
- 16 Digimatic scale unit
- 17 Profile projector
- 18 Microscope
- 19 Contracer
- 20 Surftest
- 21 Formtracer
- 22 Roundtest
- 23 Hardness tester
- 24 CMM
- 25 Flexible measuring gage
- 26 Vision measuring system
- 27 Detailed shape measuring system
- 28 Laser scan micrometer
- 29 DIY tools

List of products

Digimatic Micrometer
SERIES 293



Quickmike
SERIES 293, 369, 422



Digimatic Micrometers
SERIES 293



Outside Micrometers
SERIES 101



Outside Micrometers
SERIES 102



Quick-Setting Outside Micrometers
SERIES 293, 102



Outside Micrometers
SERIES 103



Outside Micrometers
SERIES 340, 104



Outside Micrometers
SERIES 105



Outside Micrometers
SERIES 406, 106



Spline Micrometers
SERIES 331, 111

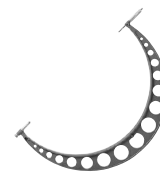

Point Micrometers
SERIES 342, 142, 112



Crimp Height Micrometers
SERIES 342, 142, 112



V-Anvil Micrometers
SERIES 314, 114



Tube Micrometers
SERIES 395, 295, 115



Universal Micrometers
SERIES 116



"Uni-Mike"
SERIES 317, 117



Sheet Metal Micrometers
SERIES 389, 189, 119, 118



Blade Micrometers
SERIES 422, 122



Disk Micrometers
SERIES 323, 223, 123



Screw Thread Micrometers
SERIES 125



Gear Tooth Micrometers
SERIES 324, 124



Screw Thread Micrometers
SERIES 326, 126



Can Seam Micrometers
SERIES 347, 147



Hub Micrometers
SERIES 147



Wire Micrometers
SERIES 147



Digit Outside Micrometers
SERIES 193



Caliper Type Micrometers
SERIES 343, 143



Digimatic Micrometers
SERIES 227



Low Force Micrometers
SERIES 227



Digimatic Bench Micrometer
SERIES 121



Snap Meters
SERIES 523



Dial Snap Meters
SERIES 523



Indicating Micrometers
SERIES 510



Outside Micrometers
SERIES 107



Limit Micrometers
SERIES 113



Optical Flats
SERIES 158



Optical Parallels
SERIES 157



Micrometer Standards
SERIES 167



Standards for Screw Thread Micrometers
SERIES 167



Standards for V-Anvil Micrometers
SERIES 167



3-Wire Units
SERIES 313



Micrometer Stands
SERIES 156



Groove Micrometers
SERIES 146



Depth Micrometers
SERIES 329, 229, 129



Depth Micrometers
SERIES 128



Digimatic Micrometer

SERIES 293 — with Dust/Water Protection Conforming to IP65 Level



• Staubdicht + strahlwassergeschützt IP65



MICROMETERS

FEATURES

- IP65 protection level, enabling use in environments exposed to cutting oil, etc*. *Anti-corrosion treatment is required after use.
- Measurement data output function is available with a water-resistant connection cable.
- Oil-resistance materials are used in all plastic components.
- $\pm 1 \mu\text{m}$ instrumental error (75 mm/3" or less range models)
- Auto power ON/OFF function.
- Certificate of inspection* is included. (50mm/2" or less range models) *It is not the type used to obtain calibration certificates.



Technical Data

Display: LCD

Functions: Origin-Set, Zero-Setting, Data hold, Automatic power on/off, inch/mm conversion (inch/mm type only), Data output

Battery: SR44 (1 pc.) (938882)

Battery life: Approx. 1.2 years under normal use

Maximum response speed: Unlimited

Dust/Water protection level: Conforming to IP65

Alarm: Low voltage, counting value composition error

Operating temperature: 0°C to 40°C



SPC cable with data switch

05CZA662: 1m
05CZA663: 2m

OPTIONAL ACCESSORIES

Order No.	Description
05CZA662	SPC cable with data switch (1m)
05CZA663	SPC cable with data switch (2m)
(See page 130.)	Micrometer stands
(See page 276.)	Gauge block set for micrometer inspection

Mitutoyo		CERTIFICATE OF INSPECTION / 検査成績書		Issue No. / 発行No. 03D404D	
1. Item / 対象製品		Digimatic Micrometer		Measuring range 0-25mm	
Product name		MDC-25MJ		Resolution 0.001mm	
Model		293-230		Serial No. 35098925	
Code No.		293-230		Standard temperature 20 °C	
2. Result of Inspection / 検査結果		Inspection standard / 検査標準		Performance / 性能	
Flatness of measuring face / 平面度		Anvil / 砵		Permissible value / 許容値 0.3	
Parallelism of measuring faces / 平行度		Spindle / 軸		Measured value / 実測値 0	
Measuring length / 測定長 (mm)		Instrumental error / 器差		Uncertainty of measurement / 測定の不確かさ	
0.0		0		U ₉₅ = 1.3	
7.7		0		(k=2)	
12.9		± 1			
17.6		0			
22.8		+1			
25.0		0			
<small> 1) Based on: JIS B 501 (1994), ISO 3611 (1978) Traceable to: NMI/AIST by JCS No.9030/AIST via No.821/263174-00, No.821/262133-99, PTE via No.4599 PTE 00 2. Judgment / 総合判定 Passed / 合格 3. QC Manager E. Otsuka / 大塚 栄 Mitutoyo Corporation </small>					

Certificate of inspection



Dimensions

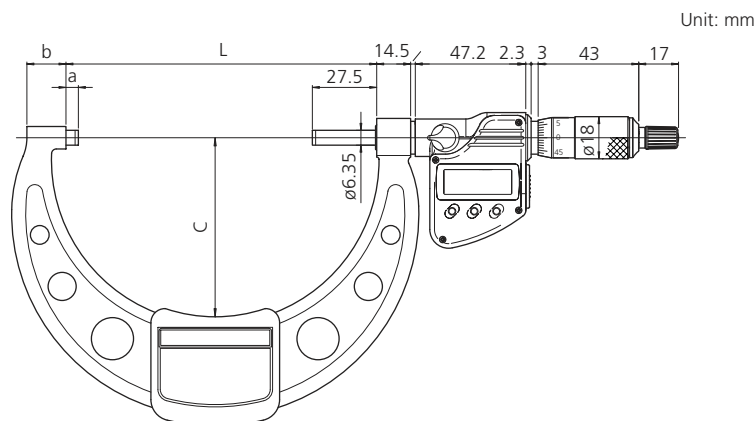
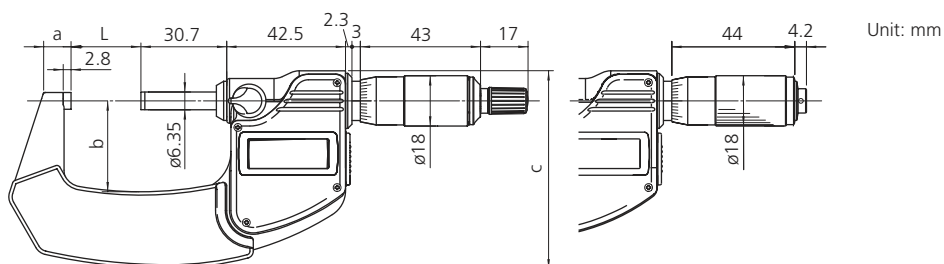

Range	L	a	b	c
0 - 25mm	0	9	25	(59.8)
25 - 50mm	25	9.8	32	(70.3)
50 - 75mm	50	12.6	47	(91.6)
75 - 100mm	75	14	60	(112.9)
100 - 125mm	132.8	5.3	16.7	(76.5)
125 - 150mm	158.2	5.7	18.8	(91)
150 - 175mm	183.6	6.1	19.1	(103.1)
175 - 200mm	208.8	6.3	18.2	(115.3)
200 - 225mm	234.2	6.7	16.8	(126.8)
225 - 250mm	258	5.5	18	(139.8)
250 - 275mm	284	6.5	18	(152.3)
275 - 300mm	309	6.5	18	(166)

SPECIFICATIONS

Metric		With ratchet stop	
Range	Order No.	Resolution	Accuracy
0 - 25mm	293-230 / 293-240*	0.001mm	±1□μm
25 - 50mm	293-231 / 293-241*	0.001mm	±1□μm
50 - 75mm	293-232 / 293-242*	0.001mm	±1□μm
75 - 100mm	293-233 / 293-243*	0.001mm	±2□μm
100 - 125mm	293-250	0.001mm	±2□μm
125 - 150mm	293-251	0.001mm	±2□μm
150 - 175mm	293-252	0.001mm	±3□μm
175 - 200mm	293-253	0.001mm	±3□μm
200 - 225mm	293-254	0.001mm	±3□μm
225 - 250mm	293-255	0.001mm	±4□μm
250 - 275mm	293-256	0.001mm	±4□μm
275 - 300mm	293-257	0.001mm	±4□μm

Inch/Metric		With ratchet stop	
Range	Order No.	Resolution	Accuracy
0 - 1"	293-330 / 293-340*	.00005"/0.001mm	±.00005"
1" - 2"	293-331 / 293-341*	.00005"/0.001mm	±.00005"
2" - 3"	293-332 / 293-342*	.00005"/0.001mm	±.00005"
3" - 4"	293-333 / 293-343*	.00005"/0.001mm	±.0001"
4" - 5"	293-350	.00005"/0.001mm	±.0001"
5" - 6"	293-351	.00005"/0.001mm	±.0001"
6" - 7"	293-352	.00005"/0.001mm	±.00015"
7" - 8"	293-353	.00005"/0.001mm	±.00015"
8" - 9"	293-354	.00005"/0.001mm	±.00015"
9" - 10"	293-355	.00005"/0.001mm	±.0002"
10" - 11"	293-356	.00005"/0.001mm	±.0002"
11" - 12"	293-357	.00005"/0.001mm	±.0002"

Metric		With ratchet thimble	
Range	Order No.	Resolution	Accuracy
0 - 25mm	293-234 / 293-244*	0.001mm	±1□μm
25 - 50mm	293-235 / 293-245*	0.001mm	±1□μm
50 - 75mm	293-236 / 293-246*	0.001mm	±1□μm
75 - 100mm	293-237 / 293-247*	0.001mm	±2□μm

Inch/Metric		With ratchet thimble	
Range	Order No.	Resolution	Accuracy
0 - 1"	293-334 / 293-344*	.00005"/0.001mm	±.00005"
1" - 2"	293-345*	.00005"/0.001mm	±.00005"
2" - 3"	293-346*	.00005"/0.001mm	±.00005"
3" - 4"	293-347*	.00005"/0.001mm	±.0001"

Metric		With friction thimble	
Range	Order No.	Resolution	Accuracy
0 - 25mm	293-238 / 293-248*	0.001mm	±1□μm

Inch/Metric		With friction thimble	
Range	Order No.	Resolution	Accuracy
0 - 1"	293-335 / 293-348*	.00005"/0.001mm	±.00005"
1" - 2"	293-336	.00005"/0.001mm	±.00005"

*without SPC data output

*without SPC data output



Quickmake

SERIES 293, 369, 422 — IP-54 Absolute Digimatic Micrometers

IP54



369-666



293-667



293-668



293-669

SPC **ABSOLUTE**

MICROMETERS

The Quickmake provides a speedy spindle feed of 10mm per thimble rotation as compared to the conventional micrometer with 0.5mm per rotation. Its wide 30mm measuring range allows various workpieces with different shapes to be measured quickly.

SPECIFICATION

Metric				
Range	Order No.	Resolution	Accuracy	Mass
0 - 30mm	293-666	0.01mm	±2μm	275g
	293-661-10*	0.01mm	±2μm	275g
25 - 55mm	293-667	0.01mm	±2μm	355g
50 - 80mm	293-668	0.01mm	±3μm	525g
75 - 105mm	293-669	0.01mm	±3μm	625g

*Without SPC data output

Excluding quantizing error

Inch/Metric				
Range	Order No.	Resolution	Accuracy	Mass
0 - 1.2"	293-676	.00005"/0.001mm	±.00008"	.61 lbs.
1" - 2.2"	293-677	.00005"/0.001mm	±.00008"	.78 lbs.
2" - 3.2"	293-678	.00005"/0.001mm	±.00012"	1.16 lbs.
3" - 4.2"	293-679	.00005"/0.001mm	±.00012"	1.38 lbs.

Excluding quantizing error

FEATURES

- Large LCD digits of 7.5mm height for error-free reading.
- Non-rotating spindle and the new ratchet friction thimble.
- With absolute linear scale.
- IP54 level water resistance protection (when not connected with data output cable).
- Stainless steel spindle.
- With SPC data output.
- With a standard bar to set the origin point (for models with a range over 30mm).

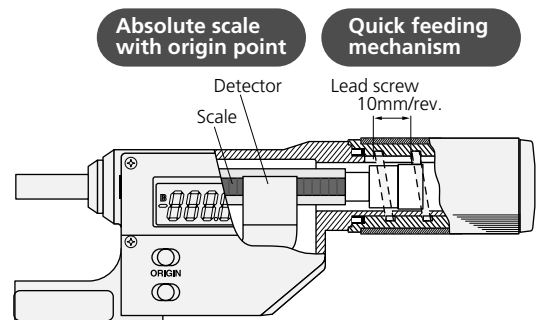



369-411

IP54

SPC

ABSOLUTE



342-451



422-411

MICROMETERS



Metric		Disk type		
Range	Order No.	Resolution	Accuracy	Mass
0 - 30mm	369-411	0.001mm	±4µm	360g
25 - 55mm	369-412	0.001mm	±4µm	490g

Excluding quantizing error

Metric		Blade type		
Range	Order No.	Resolution	Accuracy	Mass
0 - 30mm	422-411	0.001mm	±3µm	350g
25 - 55mm	422-412	0.001mm	±3µm	490g

Excluding quantizing error

Inch/Metric		Disk type		
Range	Order No.	Resolution	Accuracy	Mass
0 - 1.2"	369-421	.00005"/0.001mm	±.00016"	.79 lbs.
1" - 2.2"	369-422	.00005"/0.001mm	±.00016"	1.08 lbs.

Excluding quantizing error

Inch/Metric		Blade type		
Range	Order No.	Resolution	Accuracy	Mass
0 - 1.2"	422-421	.00005"/0.001mm	±.00012"	.77 lbs.
1" - 2.2"	422-422	.00005"/0.001mm	±.00012"	1.08 lbs.

Excluding quantizing error

Metric		Crimp height type		
Range	Order No.	Resolution	Accuracy	Mass
0 - 15mm	342-451	0.001mm	±3µm	275g

Excluding quantizing error

Dimensions

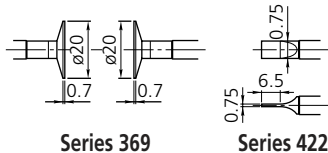
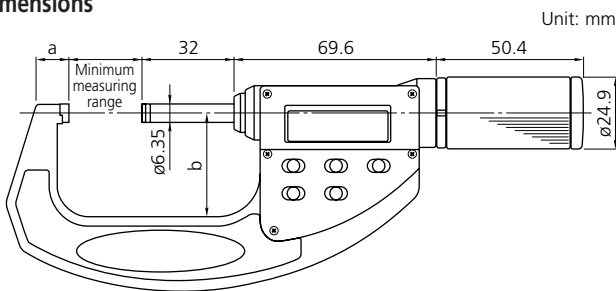

Range	a	d
0 - 30mm	9	25
25 - 55mm	11.3	36
50 - 80mm	13.1	47
75 - 105mm	13.5	60

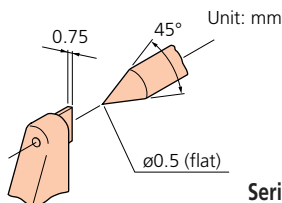

Series 342: Crimp height type

Technical Data

- Display:** LCD
- Functions:** Origin-Set, Zero-Set, power on/off, inch/mm conversion (inch/mm type only), SPC data output*, data hold
*Not provided for 293-661-10 model
- Battery:** SR44 (1 pc.) **(938882)**
- Battery life:** Approx. 3 years (**293-666, 293-661-10** and **293-676**)/Approx. 1 year
- Measuring force:** 5 - 10N (500 - 1000gf)
- Measuring faces:** Carbide-tipped (293 series only)
- Alarm:** Low battery voltage, scale contamination
- Dust/Water protection level:** Conforming to IP54

OPTIONAL ACCESSORIES

Order No.	Description
937387	SPC cable (1m)
965013	SPC cable (2m)

Digimatic Micrometers

SERIES 293



MICROMETERS

FEATURES

- The world's lightest digital micrometer 215g in mass.
- Simply measures 0 through 25mm (1") with resolution to 0.001mm.
- Measuring faces carbide tipped.
- Provided only with a zero-set key for easy origin setting. (No spindle clamp, no data output, no auto-sleep function)
- A ratchet stop or friction thimble for a constant measuring force.
- Measurement readout with large characters on the LCD screen.
- Battery: SR44 (938882) x 1pc. for 1.2 years
- Slim construction for easy access to the stepped feature like the one shown.

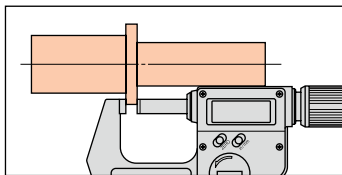

SPECIFICATIONS

Metric		With ratchet stop		
Range	Order No.	Resolution	Accuracy	Mass
0 - 25mm	293-805	0.001mm	±2µm	215g

Excluding quantizing error

Inch/Metric		With ratchet stop		
Range	Order No.	Resolution	Accuracy	Mass
0 - 1"	293-815	.00005"/0.001mm	±.0001"	.47 lbs.

Excluding quantizing error

Inch/Metric		With friction thimble		
Range	Order No.	Resolution	Accuracy	Mass
0 - 1"	293-816	.00005"/0.001mm	±.0001"	.47 lbs.

Excluding quantizing error

Dimensions

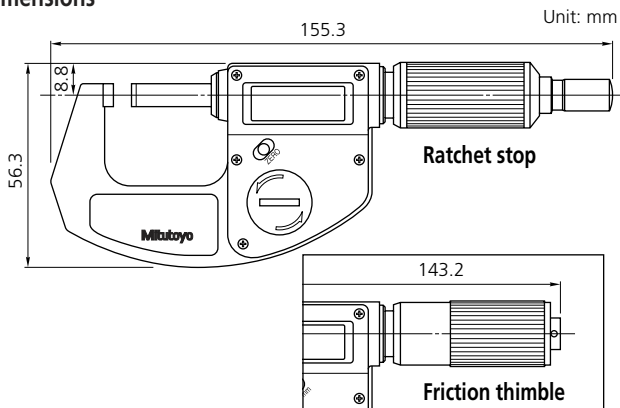

Outside Micrometers

SERIES 101

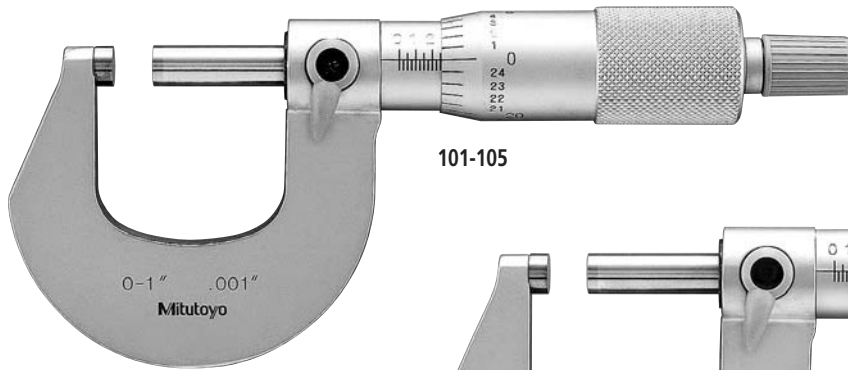

101-105

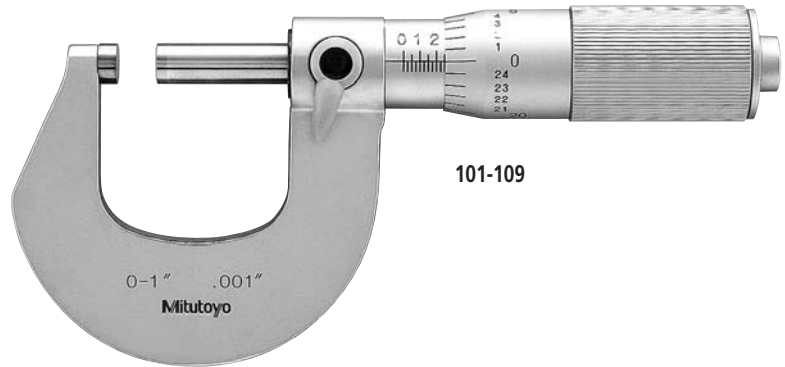

101-109

FEATURES

- Satin-chrome-finished frame, tapered (on the anvil side) for hard-to-reach places.

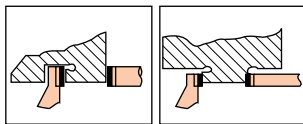

- Carbide-tipped measuring faces.
- Designed to be operated efficiently with one hand.
- Provided with a standard except for 1" model.

Measuring faces

- Flatness: .000024"
- Parallelism: .00005" for .5" model
.00008" for models up to 3"
.00012" for 3" - 4" model

SPECIFICATIONS

Inch	With ratchet stop		
Range	Order No.	Graduation	Accuracy
0 - .5"	101-230	.0001"	±.0001"
0 - 1"	101-105	.001"	±.0001"
	101-113	.0001"	±.0001"
1" - 2"	101-106	.001"	±.0001"
	101-114	.0001"	±.0001"
2" - 3"	101-119	.0001"	±.0001"
3" - 4"	101-120	.0001"	±.00015"

Note: .0001" reading is obtained with vernier.

Inch	With friction thimble		
Range	Order No.	Graduation	Accuracy
0 - 1"	101-109	.001"	±.0001"
	101-117	.0001"	±.0001"
1" - 2"	101-110	.001"	±.0001"
	101-118	.0001"	±.0001"

Note: .0001" reading is obtained with vernier.

Dimensions

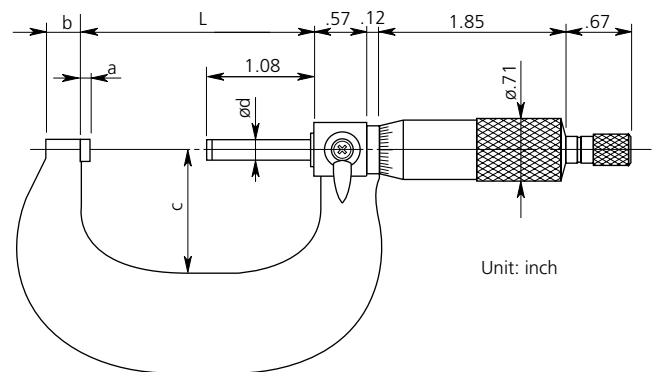

Range	L	a	b	c	d
1 - 1"	1.19	.11	.20	1.10	.25
1 - 2"	2.18	.11	.30	1.28	.25
2 - 3"	3.16	.11	.37	1.77	.25
3 - 4"	4.15	.11	.38	2.28	.25

Note: The shape of the thimble changes on the model with friction thimble.



Outside Micrometers

SERIES 102



FEATURES

- Heat-insulated frame, tapered (on the anvil side) for hard-to-reach places.
- Carbide-tipped measuring faces.
- Provided with a standard except for 25mm (1") model.

SPECIFICATIONS

Metric	With ratchet stop		
Range	Order No.	Graduation	Accuracy
0 - 25mm	102-301	0.01mm	$\pm 2\mu\text{m}$
	102-307	0.001mm	$\pm 2\mu\text{m}$
25 - 50mm	102-302	0.01mm	$\pm 2\mu\text{m}$
	102-308	0.001mm	$\pm 2\mu\text{m}$
50 - 75mm	102-303	0.01mm	$\pm 2\mu\text{m}$
75 - 100mm	102-304	0.01mm	$\pm 3\mu\text{m}$

Inch	With ratchet stop		
Range	Order No.	Graduation	Accuracy
0 - 1"	102-321	.001"	$\pm .0001$ "
	102-327	.0001"	$\pm .0001$ "
1" - 2"	102-322	.001"	$\pm .0001$ "
	102-328	.0001"	$\pm .0001$ "
2" - 3"	102-323	.001"	$\pm .0001$ "
3" - 4"	102-324	.001"	$\pm .00015$ "

Note: 0.001mm (.0001") reading is obtained with vernier.

Metric	With ratchet thimble		
Range	Order No.	Graduation	Accuracy
0 - 25mm	102-305	0.01mm	$\pm 2\mu\text{m}$
	102-309	0.001mm	$\pm 2\mu\text{m}$
25 - 50mm	102-306	0.01mm	$\pm 2\mu\text{m}$

Inch	With ratchet thimble		
Range	Order No.	Graduation	Accuracy
0 - 1"	102-325	.001"	$\pm .0001$ "
	102-329	.0001"	$\pm .0001$ "
1" - 2"	102-326	.001"	$\pm .0001$ "
	102-330	.0001"	$\pm .0001$ "

Note: 0.001mm (.0001") reading is obtained with vernier.

Measuring faces

- Flatness:
 - 0.6 μm (.000024") for models of 0.01mm (.001") reading
 - 0.3 μm (.000012") for models of 0.001mm (.0001") reading
- Parallelism:
 - 1 μm (.00004") for 25mm (1") model
 - 2 μm (.00008") for models up to 100mm (4")

Metric	Micrometer set	
Range	Order No.	Assortment of micrometers
0 - 100mm (4 mikes/set)	102-911	<ul style="list-style-type: none"> • 102-301 • 102-302 • 102-303 • 102-304 • 3 micrometer standards

Dimensions

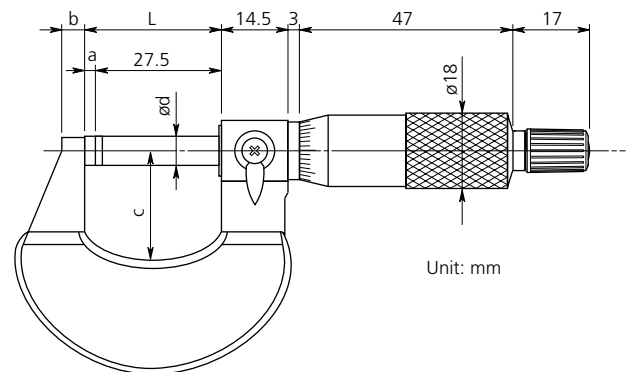

Range	L	a	b	c	d
0 - 25mm	30.3	2.8	5	26	6.35
25 - 50mm	55.3	2.8	8	32	6.35
50 - 75mm	80.3	2.8	9	45	6.35
75 - 100mm	105.3	2.8	10	58	6.35

Note: The shape of the thimble changes on the model with ratchet thimble.

Quick-Setting Outside Micrometers

SERIES 293, 102



293-151-30

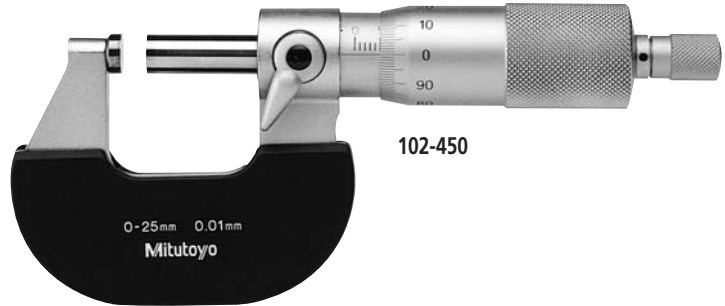

102-450

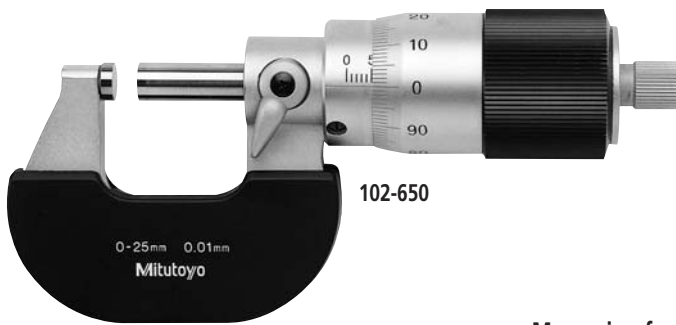

102-650

FEATURES

- 1mm spindle thread pitch for quick setting.
- The measurement can be read directly from the thimble due to the 100 step graduation.
- Carbide-tipped measuring faces.
- With Ratchet Thimble for constant force. (Ratchet Stop is also available for the 102 series.)
- Provided with a standard except for 25mm (1") model.
- The 293 series is provided with SPC output.

SPECIFICATIONS

Metric Digital model with ratchet stop			
Range	Order No.	Graduation	Accuracy
0 - 25mm	293-151-30	0.001mm	±1μm
25 - 50mm	293-152-30	0.001mm	±1μm
50 - 75mm	293-153-30	0.001mm	±1μm
75 - 100mm	293-154-30	0.001mm	±2μm

Excluding quantizing error

Metric With ratchet stop			
Range	Order No.	Graduation	Accuracy
0 - 25mm	102-450	0.01mm	±2μm
25 - 50mm	102-451	0.01mm	±2μm

Metric With ratchet thimble			
Range	Order No.	Graduation	Accuracy
0 - 25mm	102-650	0.01mm	±2μm
25 - 50mm	102-651	0.01mm	±2μm
50 - 75mm	102-652	0.01mm	±2μm
75 - 100mm	102-653	0.01mm	±2μm

Measuring faces

- Flatness: 0.6μm
- Parallelism: 2μm

Dimensions

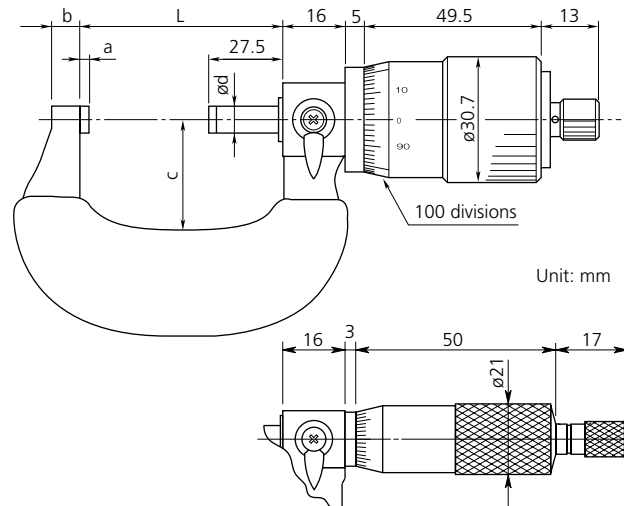

Unit: mm

Range	L	a	b	c	d
0 - 25mm	30	2.5	5	26	8
25 - 50mm	55	2.5	8	32.5	8
50 - 75mm	80	2.5	9	45	8
75 - 100mm	105	2.5	9	58	8

Note: The shape of the thimble changes on the digital model.



Outside Micrometers

SERIES 103



103-139

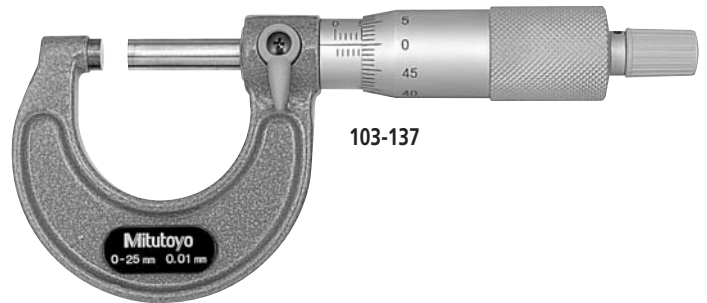

103-137

FEATURES

- Hammertone-green, baked-enamel-finished frame.
- Carbide-tipped measuring faces.
- Clear graduations on satin-chrome finish.
- Positive locking clamp.
- Ratchet Stop or Friction Thimble for exact repetitive readings.
- Provided with a standard except for 25mm (1") model.

SPECIFICATIONS

Metric	With ratchet stop		
Range	Order No.	Graduation	Accuracy
0 - 25mm	103-137	0.01mm	±2□m
	103-129	0.001mm	±2□m
25 - 50mm	103-138	0.01mm	±2□m
	103-130	0.001mm	±2□m
50 - 75mm	103-139-10	0.01mm	±2□m
75 - 100mm	103-140-10	0.01mm	±3□m
100 - 125mm	103-141-10	0.01mm	±3□m
125 - 150mm	103-142-10	0.01mm	±3□m
150 - 175mm	103-143-10	0.01mm	±4□m
175 - 200mm	103-144-10	0.01mm	±4□m
200 - 225mm	103-145-10	0.01mm	±4□m
225 - 250mm	103-146-10	0.01mm	±5□m
250 - 275mm	103-147-10	0.01mm	±5□m
275 - 300mm	103-148-10	0.01mm	±5□m
300 - 325mm	103-149	0.01mm	±6□m
325 - 350mm	103-150	0.01mm	±6□m
350 - 375mm	103-151	0.01mm	±6□m
375 - 400mm	293-152	0.01mm	±7□m
400 - 425mm	103-153	0.01mm	±7□m
425 - 450mm	103-154	0.01mm	±7□m
450 - 475mm	103-155	0.01mm	±8□m
475 - 500mm	103-156	0.01mm	±8□m

(Models with a range up to 1000mm are available.)

Measuring faces

- Flatness: 0.6□m (.000024") for models up to 300mm (12")
1□m (.00004") for models over 300mm (12")
 - Parallelism: $(2+L/100)□m [(.00008+.00004 (L/4))"]^*$
- *L=Maximum measuring length (mm) [(inch)], Fraction rounded down

Inch With ratchet stop

Range	Order No.	Graduation	Accuracy
0 - 1"	103-177	.001"	±.0001"
	103-131	.0001"	±.0001"
1" - 2"	103-178	.001"	±.0001"
	103-132	.0001"	±.0001"
2" - 3"	103-179	.001"	±.0001"
3" - 4"	103-180	.001"	±.00015"
4" - 5"	103-181	.001"	±.00015"
5" - 6"	103-182	.001"	±.00015"
6" - 7"	103-183	.001"	±.0002"
7" - 8"	103-184	.001"	±.0002"
8" - 9"	103-185	.001"	±.0002"
9" - 10"	103-186	.001"	±.00025"
10" - 11"	103-187	.001"	±.00025"
11" - 12"	103-188	.001"	±.00025"
12" - 13"	103-189	.001"	±.0003"
13" - 14"	103-190	.001"	±.0003"
14" - 15"	103-191	.001"	±.0003"
15" - 16"	103-192	.001"	±.00035"
16" - 17"	103-193	.001"	±.00035"
17" - 18"	103-194	.001"	±.00035"
18" - 19"	103-195	.001"	±.0004"
19" - 20"	103-196	.001"	±.0004"

(Models with a range up to 40" are available.)

Note: 0.001mm (.0001") reading is obtained with vernier.

Metric With friction thimble

Range	Order No.	Graduation	Accuracy
0 - 25mm	103-125	0.01mm	±2□m
	103-133	0.001mm	±2□m
25 - 50mm	103-126	0.01mm	±2□m

Inch With friction thimble

Range	Order No.	Graduation	Accuracy
0 - 1"	103-127	.001"	±.0001"
	103-135T	.0001"	±.0001"
1" - 2"	103-128	.001"	±.0001"
	103-136T	.0001"	±.0001"

Note: 0.001mm (.0001") reading is obtained with vernier.



103-913

MICROMETERS



Metric Micrometer set		
Range	Order No.	Assortment of micrometers
0 - 75mm (3 mikes/set)	103-927-10	<ul style="list-style-type: none"> • 103-137, 103-138, 103-139 • 2 micrometer standards
0 - 150mm (6 mikes/set)	103-913-30	<ul style="list-style-type: none"> • 103-137, 103-138, 103-139-10, 103-140-10, 103-141-10, 103-142-10 • 5 micrometer standards
150 - 300mm (6 mikes/set)	103-915-10	<ul style="list-style-type: none"> • 103-143, 103-144, 103-145, 103-146, 103-147, 103-148 • 6 micrometer standards
0 - 300mm (12 mikes/set)	103-914-30	<ul style="list-style-type: none"> • All micrometers of 103-913-30 and 103-915-10 in one set • 11 micrometer standards

Inch		
Range	Order No.	Assortment of micrometers
0 - 3" (3 mikes/set)	103-929	<ul style="list-style-type: none"> • 103-177, 103-178, 103-179 • 2 micrometer standards
0 - 4" (4 mikes/set)	103-930	<ul style="list-style-type: none"> • 103-177, 103-178, 103-179, 103-180 • 3 micrometer standards
0 - 6" (6 mikes/set)	103-904	<ul style="list-style-type: none"> • 101-105, 101-106, 103-179, 103-180, 103-181, 103-182 • 5 micrometer standards
6" - 12" (6 mikes/set)	103-906	<ul style="list-style-type: none"> • 103-183, 103-184, 103-185, 103-186, 103-187, 103-188 • 6 micrometer standards
0 - 12" (12 mikes/set)	103-905	<ul style="list-style-type: none"> • All micrometers of 103-904 and 103-906 in one set • 11 micrometer standards

Outside Micrometers

SERIES 340, 104 — with Interchangeable Anvils

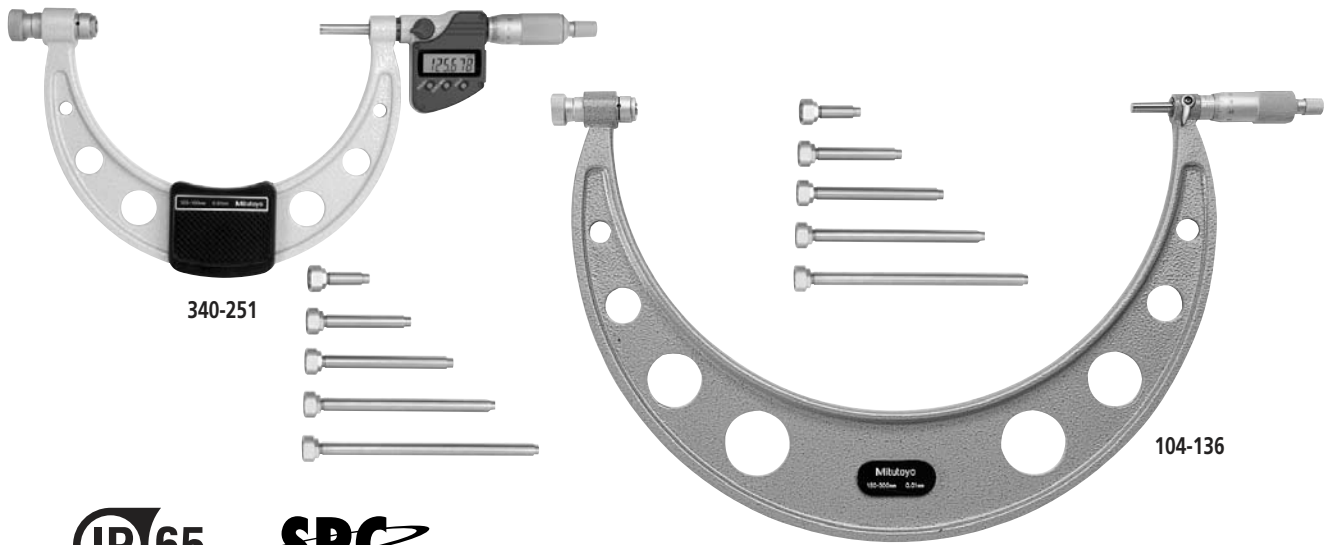

FEATURES

- IP65 water/dust protection level (340 series*).
- *Models with a range up to 300mm (12").
- Wide measuring range with interchangeable anvils.
- Carbide-tipped spindle face.
- Provided with a Ratchet Stop for constant force.
- Supplied with zero-setting standards for each range.
- The 340 series (LCD readout type) is provided with SPC output.

SPECIFICATIONS

Metric		Digital model	
Range	Order No.	Resolution	Interchangeable anvils
0 - 150mm	340-251	0.001mm	0, 25, 50, 75, 100, 125mm
150 - 300mm	340-252	0.001mm	0, 25, 50, 75, 100, 125mm
300 - 400mm	340-513	0.001mm	0, 25, 50, 75mm
400 - 500mm	340-514	0.001mm	0, 25, 50, 75mm
500 - 600mm	340-515	0.001mm	0, 25, 50, 75mm
600 - 700mm	340-516	0.001mm	0, 25, 50, 75mm
700 - 800mm	340-517	0.001mm	0, 25, 50, 75mm
800 - 900mm	340-518	0.001mm	0, 25, 50, 75mm
900 - 1000mm	340-519	0.001mm	0, 25, 50, 75mm

Inch/Metric		Digital model	
Range	Order No.	Resolution	Interchangeable anvils
0 - 6"	340-351	.00005"/0.001mm	0, 1", 2", 3", 4", 5"
6" - 12"	340-352	.0001"/0.001mm	0, 1", 2", 3", 4", 5"
12" - 18"	340-713	.0001"/0.001mm	0, 1", 2", 3", 4", 5"
18" - 24"	340-714	.0001"/0.001mm	0, 1", 2", 3", 4", 5"
24" - 30"	340-715	.0001"/0.001mm	0, 1", 2", 3", 4", 5"
30" - 36"	340-716	.0001"/0.001mm	0, 1", 2", 3", 4", 5"

Accuracy

- $\pm(4+L/75)\mu\text{m}$ [$\pm(.0002+.00005(L/3))$ "]*
- *L=Maximum measuring length (mm) [(inch)], Fraction rounded up, Excluding quantizing error (340 series)

Metric

Range	Order No.	Graduation	Interchangeable anvils
0 - 50mm	104-171*	0.01mm	0, 25mm
0 - 100mm	104-139A	0.01mm	0, 25, 50, 75mm
0 - 150mm	104-135A	0.01mm	0, 25, 50, 75, 100, 125mm
100 - 200mm	104-140A	0.01mm	0, 25, 50, 75mm
150 - 300mm	104-136A	0.01mm	0, 25, 50, 75, 100, 125mm
200 - 300mm	104-141A	0.01mm	0, 25, 50, 75mm
300 - 400mm	104-142A	0.01mm	0, 25, 50, 75mm
400 - 500mm	104-143A	0.01mm	0, 25, 50, 75mm
500 - 600mm	104-144A	0.01mm	0, 25, 50, 75mm
600 - 700mm	104-145A	0.01mm	0, 25, 50, 75mm
700 - 800mm	104-146A	0.01mm	0, 25, 50, 75mm
800 - 900mm	104-147A	0.01mm	0, 25, 50, 75mm
900 - 1000mm	104-148A	0.01mm	0, 25, 50, 75mm

*The frame in a heat insulating cover

Inch

Range	Order No.	Graduation	Interchangeable anvils
0 - 2"	104-166	.001"	0, 1"
	104-165	.0001"	0, 1"
0 - 4"	104-149	.001"	0, 1", 2", 3"
0 - 6"	104-137	.001"	0, 1", 2", 3", 4", 5"
6" - 12"	104-138	.001"	0, 1", 2", 3", 4", 5"
12" - 18"	104-201	.001"	0, 1", 2", 3", 4", 5"
18" - 24"	104-202	.001"	0, 1", 2", 3", 4", 5"
24" - 30"	104-203	.001"	0, 1", 2", 3", 4", 5"
30" - 36"	104-204	.001"	0, 1", 2", 3", 4", 5"
36" - 42"	104-205	.001"	0, 1", 2", 3", 4", 5"

Note: .0001" reading is obtained with vernier.

Measuring faces

- Flatness:
 - 0.6μm (.000024") for models up to 300mm (12")
 - 1μm (.00004") for models over 300mm (12")
- Parallelism: $(2+L/100)\mu\text{m}$ [$(.00008+.00004(L/4))$ "]**
- **L=Maximum measuring length (mm) [(inch)], Fraction rounded up

Outside Micrometers

SERIES 105 — with Extension Anvil Collars

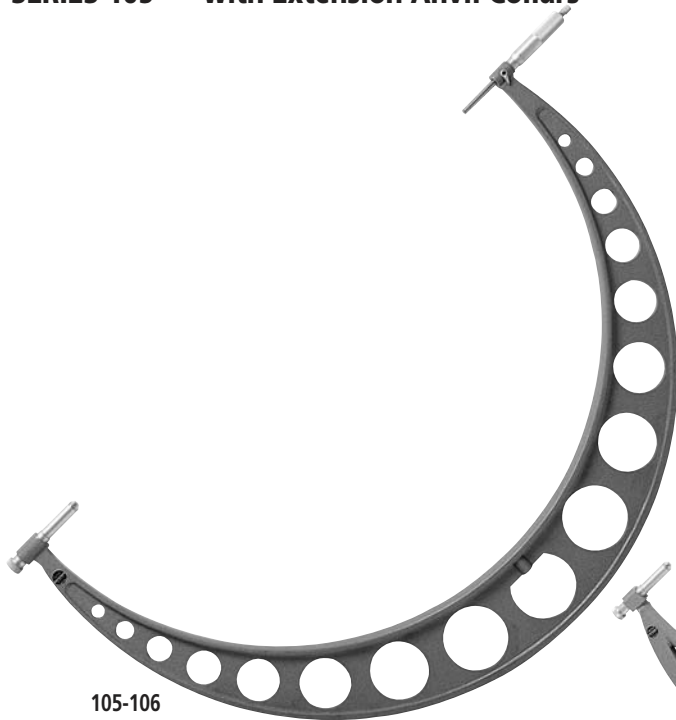

105-106

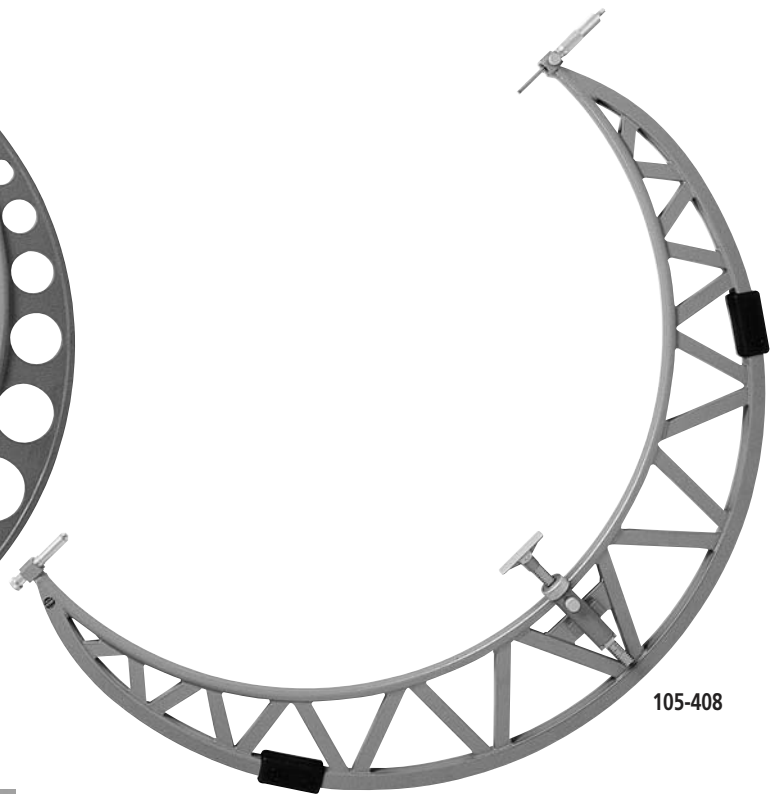

105-408

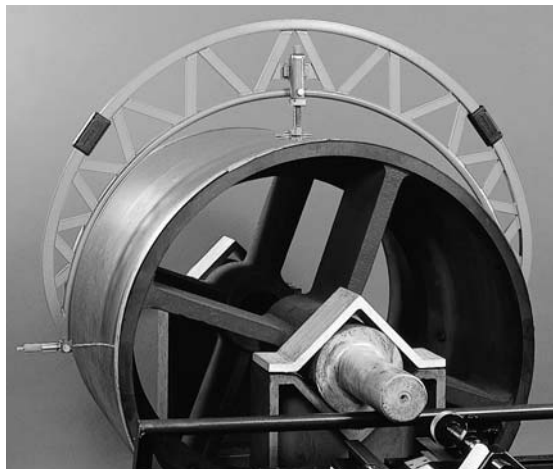

FEATURES

- Wide measuring range with extension anvil collars.



- 50mm (2") spindle stroke.
- Carbide-tipped measuring faces.
- Provided with Ratchet Stop for constant force.
- Supplied with zero-setting standards for each range.
- Square and round pipes are combined for light weight and rigid frame (for models over 1000mm range).
- Workpiece stopper (for models over 1000mm range).

SPECIFICATIONS

Metric			
Range	Order No.	Graduation	Extension collars
500 - 600mm	105-103	0.01mm	50mm
600 - 700mm	105-104	0.01mm	50mm
700 - 800mm	105-105	0.01mm	50mm
800 - 900mm	105-106	0.01mm	50mm
900 - 1000mm	105-107	0.01mm	50mm
1000 - 1100mm	105-408	0.01mm	50mm
1100 - 1200mm	105-409	0.01mm	50mm
1000 - 1200mm	105-418	0.01mm	50mm, 100mm
1200 - 1300mm	105-410	0.01mm	50mm
1300 - 1400mm	105-411	0.01mm	50mm
1200 - 1400mm	105-419	0.01mm	50mm, 100mm
1400 - 1500mm	105-412	0.01mm	50mm
1500 - 1600mm	105-413	0.01mm	50mm
1400 - 1600mm	105-420	0.01mm	50mm, 100mm
1600 - 1700mm	105-414	0.01mm	50mm
1700 - 1800mm	105-415	0.01mm	50mm
1600 - 1800mm	105-421	0.01mm	50mm, 100mm
1800 - 1900mm	105-416	0.01mm	50mm
1900 - 2000mm	105-417	0.01mm	50mm
1800 - 2000mm	105-422	0.01mm	50mm, 100mm

Accuracy

- $\pm(6+L/75)\mu\text{m}^*$
- *L=Maximum measuring length (mm), Fraction rounded up

Measuring faces

- Flatness: $1\mu\text{m}$
- Parallelism: $(2+L/100)\mu\text{m}^{**}$
- **L=Maximum measuring length (mm), Fraction rounded down



Outside Micrometers

SERIES 406, 106 — Non-Rotating Spindle Type



406-521-30

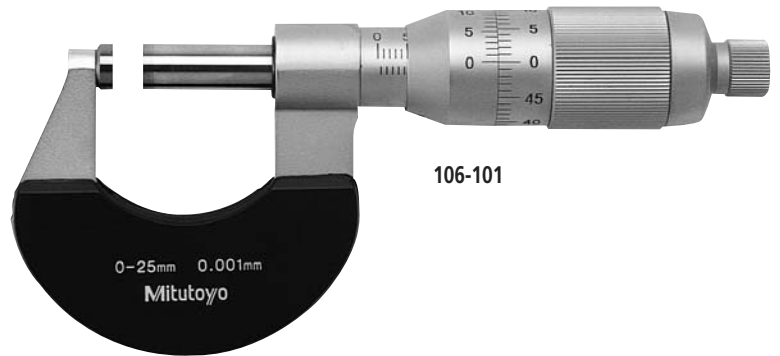

106-101

MICROMETERS

FEATURES

- Carbide-tipped measuring faces.
- Easy-to-read with large vernier on the thimble.
- Provided with a standard except for 25mm (1") model.

SPECIFICATIONS

Metric	Digital model with ratchet stop		
Range	Order No.	Resolution	Accuracy
0 - 25mm	406-521-30	0.001mm	±3μm
25 - 50mm	406-522-30	0.001mm	±3μm
50 - 75mm	406-523-30	0.001mm	±3μm
75 - 100mm	406-524-30	0.001mm	±4μm

Excluding quantizing error

Metric	With ratchet thimble		
Range	Order No.	Resolution	Accuracy
0 - 25mm	106-101	0.001mm	±2μm
25 - 50mm	106-103	0.001mm	±2μm
50 - 75mm	106-105	0.001mm	±3μm
75 - 100mm	106-106	0.001mm	±4μm

Inch/Metric	Digital model with ratchet stop		
Range	Order No.	Resolution	Accuracy
0 - 1"	406-721-30	.00005"/0.001mm	±.00015"
1" - 2"	406-722-30	.00005"/0.001mm	±.00015"
2" - 3"	406-723-30	.00005"/0.001mm	±.00015"
3" - 4"	406-724-30	.00005"/0.001mm	±.0002"

Excluding quantizing error

Inch	With friction thimble		
Range	Order No.	Graduation	Accuracy
0 - 1"	106-102	.0001"	±.0001"
1" - 2"	106-104	.0001"	±.0001"

Measuring faces

- Flatness: 0.3μm (.000012")
- Parallelism: 4μm (.00016") for Series 406
2μm (.00008") for Series 106
- Diameter: 6.35mm (.25") for Series 406
8mm (.315") for Series 106

Spline Micrometers

SERIES 331, 111



331-251



111-115



FEATURES

- IP65 water/dust protection level (331 series).
- The anvil and spindle have a small diameter for measuring splined shafts, slots, and keyways.

Anvil/Spindle Dimensions

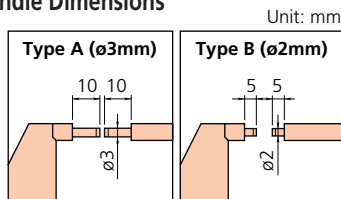

- Carbide-tipped measuring faces.
- With Ratchet Stop for constant force.
- Provided with a standard except for 25mm (1") model.
- The 331 series is provided with SPC output.

SPECIFICATIONS

Metric		Digital model		
Range	Order No.	Resolution	Accuracy	Remarks
0 - 25mm	331-251	0.001mm	±2µm	Type A
	331-261	0.001mm	±2µm	Type B
25 - 50mm	331-252	0.001mm	±2µm	Type A
	331-262	0.001mm	±2µm	Type B
50 - 75mm	331-253	0.001mm	±2µm	Type A
	331-263	0.001mm	±2µm	Type B
75 - 100mm	331-254	0.001mm	±3µm	Type A
	331-264	0.001mm	±3µm	Type B

Excluding quantizing error

Inch/Metric		Digital model		
Range	Order No.	Resolution	Accuracy	Remarks
0 - 1"	331-351	.00005"/0.001mm	±.0001"	Type A
	331-361	.00005"/0.001mm	±.0001"	Type B
1" - 2"	331-352	.00005"/0.001mm	±.0001"	Type A
	331-362	.00005"/0.001mm	±.0001"	Type B
2" - 3"	331-353	.00005"/0.001mm	±.0001"	Type A
	331-363	.00005"/0.001mm	±.0001"	Type B
3" - 4"	331-354	.00005"/0.001mm	±.00015"	Type A
	331-364	.00005"/0.001mm	±.00015"	Type B

Excluding quantizing error

Metric				
Range	Order No.	Graduation	Accuracy	Remarks
0 - 25mm	111-115	0.01mm	±3µm	Type A
	111-215	0.01mm	±3µm	Type B
25 - 50mm	111-116	0.01mm	±3µm	Type A
50 - 75mm	111-117	0.01mm	±3µm	Type A
75 - 100mm	111-118	0.01mm	±4µm	Type A
100 - 125mm	111-119	0.01mm	±4µm	Type A
125 - 150mm	111-120	0.01mm	±4µm	Type A
150 - 175mm	111-121	0.01mm	±5µm	Type A
175 - 200mm	111-122	0.01mm	±5µm	Type A

Inch				
Range	Order No.	Resolution	Accuracy	Remarks
0 - 1"	111-166	.0001"	±.00015"	Type A
1" - 2"	111-142	.001"	±.00015"	Type A
2" - 3"	111-143	.001"	±.00015"	Type A

Note: .0001" reading is obtained with vernier.

Measuring faces

- Flatness: 0.3µm (.000012")
 - Parallelism: (2+L/100)µm [(0.00008+.00004 (L/4))"]*
- *L=Maximum measuring length (mm) [(inch)], Fraction rounded up



Point Micrometers

SERIES 342, 142, 112



342-261

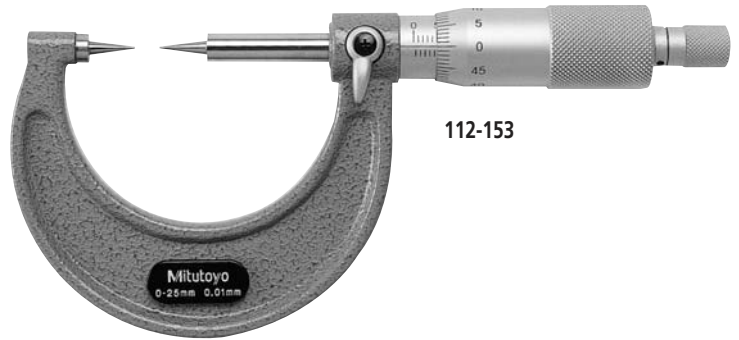

112-153



FEATURES

- IP65 water/dust protection level (342 series).
- Pointed spindle and anvil for measuring the web thickness of drills, small grooves, keyways, and other hard-to-reach dimensions.
- 15 degree and 30 degree measuring points are available.
- The measuring points (carbide-tipped) have approximately 0.3mm (.012") radius.

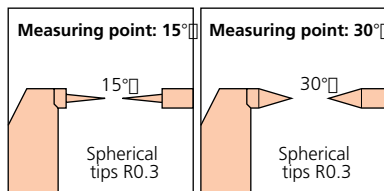

- With Ratchet Stop for constant force.
- The 342 series is provided with SPC output.
- The 142 series is provided with a digit counter.
- Provided with a standard except for 25mm (1") models.

Dimensions

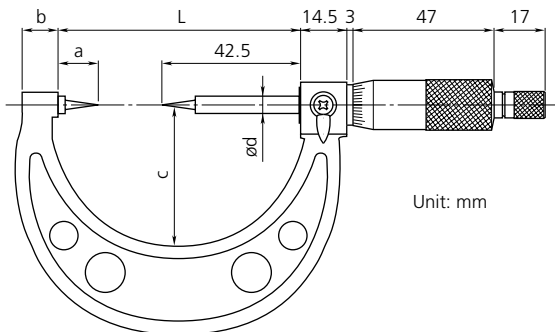

Unit: mm

Range	L	a	b	c	d
0 - 25mm	55.3	12.8	10	38	6.35
25 - 50mm	80.3	12.8	12	49	6.35
50 - 75mm	105.3	12.8	14	60	6.35
75 - 100mm	132.8	15.3	17	79	6.35

SPECIFICATIONS

Metric	Digital model	Range	Order No.	Resolution	Accuracy	Point
0 - 25mm	342-251	0.001mm		0.001mm	±2µm	15°
	342-261	0.001mm		0.001mm	±2µm	30°
25 - 50mm	342-252	0.001mm		0.001mm	±2µm	15°
	342-262	0.001mm		0.001mm	±2µm	30°
50 - 75mm	342-253	0.001mm		0.001mm	±2µm	15°
	342-263	0.001mm		0.001mm	±2µm	30°
75 - 100mm	342-254	0.001mm		0.001mm	±3µm	15°
	342-264	0.001mm		0.001mm	±3µm	30°

Excluding quantizing error

Inch/Metric	Digital model	Range	Order No.	Resolution	Accuracy	Point
0 - 1"	342-351	.00005"/0.001mm		.00005"/0.001mm	±.0001"	15°
	342-361	.00005"/0.001mm		.00005"/0.001mm	±.0001"	30°
1" - 2"	342-352	.00005"/0.001mm		.00005"/0.001mm	±.0001"	15°
	342-362	.00005"/0.001mm		.00005"/0.001mm	±.0001"	30°
2" - 3"	342-353	.00005"/0.001mm		.00005"/0.001mm	±.0001"	15°
	342-363	.00005"/0.001mm		.00005"/0.001mm	±.0001"	30°
3" - 4"	342-354	.00005"/0.001mm		.00005"/0.001mm	±.00015"	15°
	342-364	.00005"/0.001mm		.00005"/0.001mm	±.00015"	30°

Excluding quantizing error

Metric	Range	Order No.	Graduation	Accuracy	Point
0 - 25mm	142-153		0.01mm	±3µm	15°
	142-201		0.01mm	±3µm	30°

Inch	Range	Order No.	Graduation	Accuracy	Point
0 - 1"	142-177		.001"	±.00015"	15°
	142-225		.001"	±.00015"	30°

Measuring points

- Parallelism: 3µm (.00012")



Metric				
Range	Order No.	Graduation	Accuracy	Point
0 - 25mm	112-165	0.01mm	±3μm	15°
	112-153*	0.01mm	±3μm	15°
	112-213	0.01mm	±3μm	30°
	112-201*	0.01mm	±3μm	30°
25 - 50mm	112-166	0.01mm	±3μm	15°
	112-154*	0.01mm	±3μm	15°
	112-214	0.01mm	±3μm	30°
	112-202*	0.01mm	±3μm	30°
50 - 75mm	112-167	0.01mm	±3μm	15°
	112-155*	0.01mm	±3μm	15°
	112-215	0.01mm	±3μm	30°
	112-203*	0.01mm	±3μm	30°
75 - 100mm	112-168	0.01mm	±4μm	15°
	112-156*	0.01mm	±4μm	15°
	112-216	0.01mm	±4μm	30°
	112-204*	0.01mm	±4μm	30°

*The points have not carbide tips.

Inch				
Range	Order No.	Graduation	Accuracy	Point
0 - 1"	112-189	.001"	±.00015"	15°
	112-177*	.001"	±.00015"	15°
	112-237	.001"	±.00015"	30°
	112-225*	.001"	±.00015"	30°
1" - 2"	112-190	.001"	±.00015"	15°
	112-178*	.001"	±.00015"	15°
	112-238	.001"	±.00015"	30°
	112-226*	.001"	±.00015"	30°
2" - 3"	112-191	.001"	±.00015"	15°

*The points have not carbide tips.

Crimp Height Micrometers

SERIES 342, 142, 112 — Point Spindle and Blade Anvil

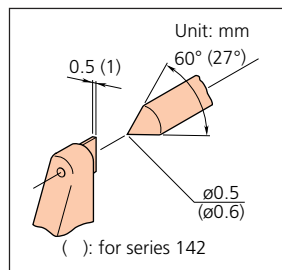
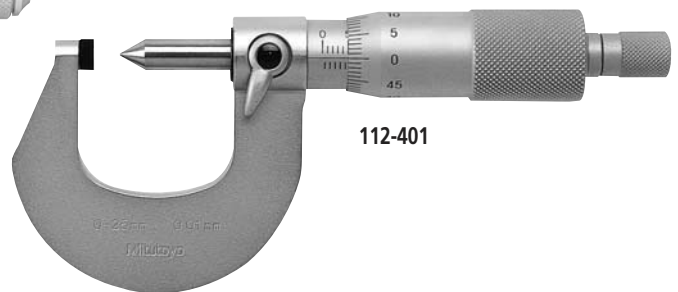

FEATURES

- IP65 water/dust protection level (342 series).
- Measures the height of crimp contacts.
- With Ratchet Stop for constant force.
- The 342 series is provided with SPC output.
- The 142 series is provided with a digit counter.

SPECIFICATIONS

Metric		Digital model	
Range	Order No.	Resolution	Accuracy
0 - 25mm	342-271	0.001mm	±3μm
Excluding quantizing error			

Inch/Metric		Digital model	
Range	Order No.	Resolution	Accuracy
0 - 1"	342-371	.00005"/0.001mm	±.00015"
Excluding quantizing error			

Metric		Mechanical counter model	
Range	Order No.	Graduation	Accuracy
0 - 25mm	142-402	0.01mm	±3μm
	142-403	0.001mm	±3μm

Note: 0.001mm reading is obtained with vernier.

Metric		Mechanical counter model	
Range	Order No.	Graduation	Accuracy
0 - 25mm	112-401	0.01mm	±3μm

V-Anvil Micrometers

SERIES 314, 114 — 3 Flutes and 5 Flutes



314-251

IP65 SPC



114-121

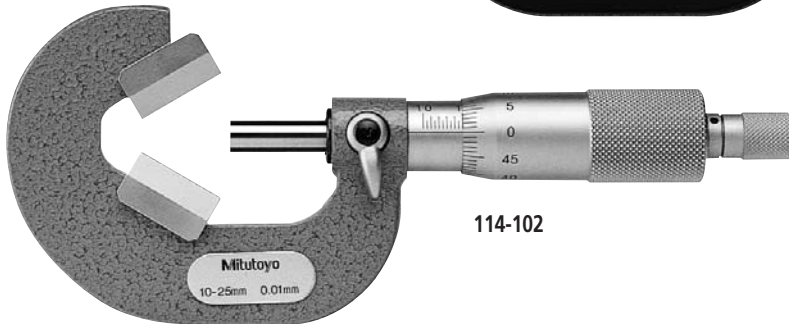

114-102

FEATURES

- IP65 water/dust protection level (314 series).
- Measures the outside diameter of cutting heads (such as taps, reamers, end mills) with an odd number of flutes.
- Carbide-tipped spindle.
- With Ratchet Stop for constant force.
- V-anvils with a centerline groove are available. They are useful for measuring pitch diameters of taps which have a small diameter by using single-wire method.
- Supplied with a standard for zero point adjustment.
- The 314 series (LCD readout type) is provided with SPC output.

Pitch Diameter Measurement of Tap by Single-wire Method

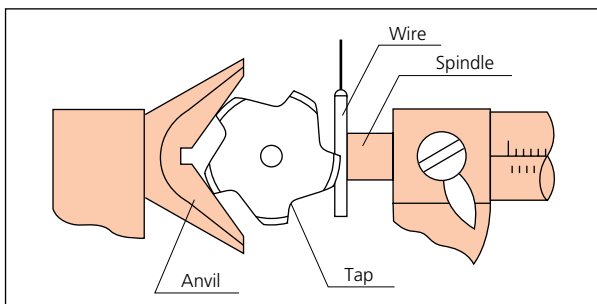

SPECIFICATIONS

Metric		Digital model for 3 flutes cutting head		
Range	Order No.	Resolution	Accuracy	Remarks
1 - 15mm	314-251	0.001mm	±4μm	w/Groove
	314-261	0.001mm	±4μm	—
10 - 25mm	314-252	0.001mm	±4μm	w/Groove
	314-262	0.001mm	±4μm	—
25 - 40mm	314-253	0.001mm	±5μm	—

Excluding quantizing error

Inch/Metric		Digital model for 3 flutes cutting head		
Range	Order No.	Resolution	Accuracy	Remarks
.05 - .6"	314-351	.00005"/0.001mm	±.0002"	w/Groove
	314-361	.00005"/0.001mm	±.0002"	—
.4" - 1"	314-352	.00005"/0.001mm	±.0002"	w/Groove
	314-362	.00005"/0.001mm	±.0002"	—
1" - 1.6"	314-353	.00005"/0.001mm	±.00025"	—

Excluding quantizing error





Metric For 3 flutes cutting head

Range	Order No.	Graduation	Accuracy	Remarks
1 - 15mm	114-101	0.01mm	±4μm	w/Groove
	114-161	0.01mm	±4μm	—
10 - 25mm	114-102	0.01mm	±4μm	w/Groove
	114-162	0.01mm	±4μm	—
2.3 - 25mm	114-204*	0.01mm	±4μm	—
25 - 40mm	114-103	0.01mm	±5μm	—
40 - 55mm	114-104	0.01mm	±6μm	—
55 - 70mm	114-105	0.01mm	±6μm	—
70 - 85mm	114-106	0.01mm	±7μm	—
85 - 100mm	114-107	0.01mm	±7μm	—

*Carbide-tipped anvil

Inch For 3 flutes cutting head

Range	Order No.	Graduation	Accuracy	Remarks
.05 - .6"	114-163	.001"	±.0002"	—
.09" - 1"	114-202*	.0001"	±.0002"	—
1" - 1.6"	114-113	.001"	±.00025"	—
1.6" - 2.2"	114-114	.001"	±.0003"	—

*Carbide-tipped anvil

Note: .0001" reading is obtained with vernier.

Metric For 5 flutes cutting head

Range	Order No.	Graduation	Accuracy	Remarks
5 - 25mm	114-121	0.01mm	±4μm	w/Groove
	114-165	0.01mm	±4μm	—
2.3 - 25mm	114-137*	0.01mm	±4μm	—
25 - 45mm	114-122	0.01mm	±5μm	—
45 - 65mm	114-123	0.01mm	±6μm	—
65 - 85mm	114-124	0.01mm	±7μm	—

*Carbide-tipped anvil

Inch For 5 flutes cutting head

Range	Order No.	Graduation	Accuracy	Remarks
.09" - 1"	114-135*	.0001"	±.0002"	—
1" - 1.8"	114-129	.001"	±.00025"	—

*Carbide-tipped anvil

Note: .0001" reading is obtained with vernier.

Metric For 7 flutes cutting head

Range	Order No.	Graduation	Accuracy	Remarks
5 - 25mm	114-151	0.01mm	±4μm	—
25 - 45mm	114-152	0.01mm	±5μm	—

Dimensions

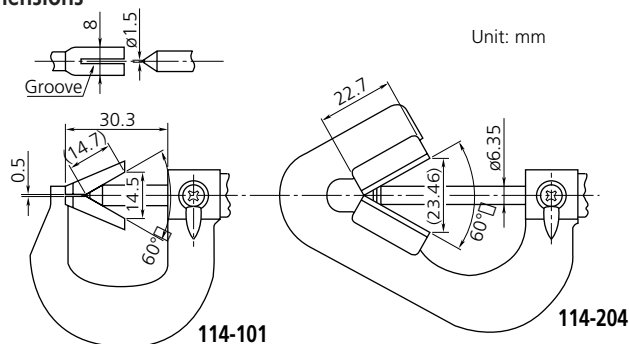

Unit: mm

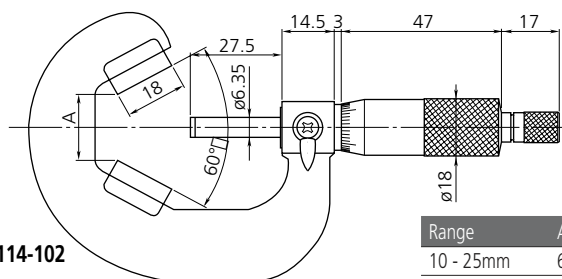

Range	A
10 - 25mm	6.2
25 - 40mm	19.14
40 - 55mm	32.13
55 - 70mm	45.12
70 - 85mm	58.11
85 - 100mm	71.1

Tube Micrometers

SERIES 395, 295, 115 — Spherical and Cylindrical Anvils

Spherical Anvil Type



395-251

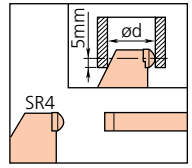

395-271

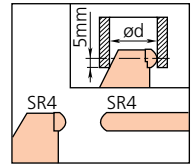

FEATURES

- IP65 water/dust protection level (395 series).
- Designed to measure the wall thickness of various tubing.
- The Tube Micrometers have two combinations of measuring faces (carbide-tipped): spherical-flat type, and spherical-spherical type.
- Cylindrical anvils (perpendicular) are also available.
- With Ratchet Stop for constant force.
- Provided with a standard except for 25mm (1") model.
- The 295 series is provided with a digit counter.

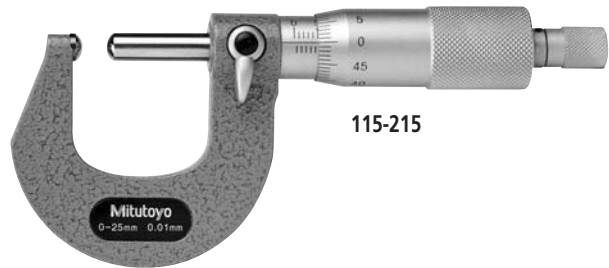

115-215

Cylindrical Anvil Type



395-261

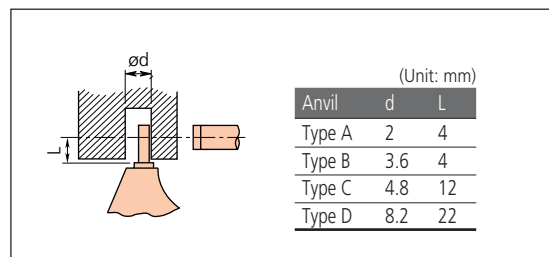
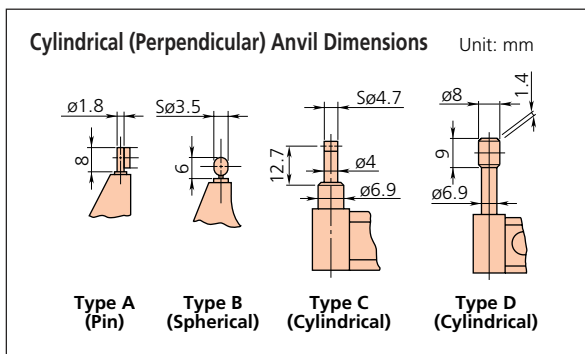
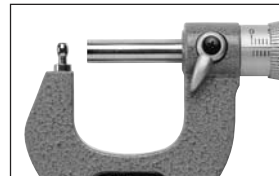

SPECIFICATIONS

Metric Digital model with spherical anvil				
Range	Order No.	Resolution	Accuracy	Mini. ID of tubing
0 - 25mm	395-251	0.001mm	±2μm	d: 15mm
	395-271*	0.001mm	±2μm	d: 15mm
25 - 50mm	395-252	0.001mm	±2μm	d: 15mm
	395-272*	0.001mm	±2μm	d: 15mm
50 - 75mm	395-253	0.001mm	±2μm	d: 19mm
	395-273*	0.001mm	±2μm	d: 19mm
75 - 100mm	395-254	0.001mm	±3μm	d: 20mm
	395-274*	0.001mm	±3μm	d: 20mm

*Spherical-spherical type

Excluding quantizing error

Inch/Metric Digital model with spherical anvil				
Range	Order No.	Resolution	Accuracy	Mini. ID of tubing
0 - 1"	395-351	.00005"/0.001mm	±.0001"	d: .59"
	395-371*	.00005"/0.001mm	±.0001"	d: .59"
1" - 2"	395-352	.00005"/0.001mm	±.0001"	d: .59"
	395-372*	.00005"/0.001mm	±.0001"	d: .59"
2" - 3"	395-353	.00005"/0.001mm	±.0001"	d: .75"
	395-373*	.00005"/0.001mm	±.0001"	d: .75"
3" - 4"	395-354	.00005"/0.001mm	±.00015"	d: .79"
	395-374*	.00005"/0.001mm	±.00015"	d: .79"

*Spherical-spherical type

Excluding quantizing error

Metric Digital model with cylindrical anvil				
Range	Order No.	Resolution	Accuracy	Remarks
0 - 25mm	395-261	0.001mm	±3μm	Type A
	395-262	0.001mm	±3μm	Type B
	395-263	0.001mm	±3μm	Type C
	395-264	0.001mm	±3μm	Type D

Excluding quantizing error

Inch/Metric Digital model with cylindrical anvil				
Range	Order No.	Resolution	Accuracy	Remarks
0 - 1"	395-362	.00005"/0.001mm	±.00015"	Type B
	395-363	.00005"/0.001mm	±.00015"	Type C
	395-364	.00005"/0.001mm	±.00015"	Type D

Excluding quantizing error

Metric Mechanical counter model with spherical anvil				
Range	Order No.	Graduation	Accuracy	Mini. ID of tubing
0 - 25mm	295-115	0.01mm	±3μm	d: 10mm
	295-215*	0.01mm	±3μm	d: 10mm

*Spherical-spherical type

Inch Mechanical counter model with spherical anvil				
Range	Order No.	Graduation	Accuracy	Mini. ID of tubing
0 - 1"	295-153	.0001"	±.00015"	d: .40"
	295-253*	.0001"	±.00015"	d: .40"

*Spherical-spherical type

Metric With spherical anvil				
Range	Order No.	Graduation	Accuracy	Mini. ID of tubing
0 - 25mm	115-115	0.01mm	±3μm	d: 10mm
	115-215*	0.01mm	±3μm	d: 10mm
25 - 50mm	115-116	0.01mm	±3μm	d: 11mm
	115-216*	0.01mm	±3μm	d: 11mm
50 - 75mm	115-117	0.01mm	±3μm	d: 17mm
	115-217*	0.01mm	±3μm	d: 17mm
75 - 100mm	115-118	0.01mm	±4μm	d: 18mm
	115-218*	0.01mm	±4μm	d: 18mm

*Spherical-spherical type

Inch With spherical anvil				
Range	Order No.	Graduation	Accuracy	Mini. ID of tubing
0 - 1"	115-153	.0001"	±.00015"	d: .40"
	115-253*	.0001"	±.00015"	d: .40"
1" - 2"	115-142	.001"	±.00015"	d: .44"
	115-242*	.001"	±.00015"	d: .44"
2" - 3"	115-143	.001"	±.00015"	d: .67"
	115-243*	.001"	±.00015"	d: .67"
3" - 4"	115-144	.001"	±.0002"	d: .71"

*Spherical-spherical type

Note: .0001" reading is obtained with vernier.

Metric With cylindrical anvil				
Range	Order No.	Graduation	Accuracy	Remarks
0 - 25mm	115-302	0.01mm	±3μm	Type A
	115-308	0.01mm	±3μm	Type B
	115-315	0.01mm	±3μm	Type C
	115-316	0.01mm	±3μm	Type D
25 - 50mm	115-303	0.01mm	±3μm	Type A
	115-309	0.01mm	±3μm	Type B

Inch With cylindrical anvil				
Range	Order No.	Graduation	Accuracy	Remarks
0 - 1"	115-305	.001"	±.00015"	Type A
	115-313	.0001"	±.00015"	Type C
	115-314	.0001"	±.00015"	Type D

Note: .0001" reading is obtained with vernier.



Universal Micrometers

SERIES 116 — Interchangeable Anvil Type



116-101

FEATURES

- Non-rotating spindle with seven interchangeable anvils (flat, spline, spherical, point, knife-edge, disk, and blade) for a wide range of applications.
- Interchangeable anvils (pair) are optional.
- V-anvils and conical spindle tips (matching pair) for screw thread measurement are also available.
- With Ratchet Stop for constant force.
- Provided with a standard except for 25mm (1") model.

SPECIFICATIONS

Metric			
Range	Order No.	Graduation	Accuracy
0 - 25mm	116-101	0.01mm	±4μm
25 - 50mm	116-102	0.01mm	±4μm

Inch			
Range	Order No.	Graduation	Accuracy
0 - 1"	116-105	.001"	±.0002"
1" - 2"	116-106	.001"	±.0002"

V-Anvils and Conical Spindle Tips Sets (Optional)

Applications	Order No.	Assortment of anvils and tips
Screw thread measurements (Metric screw, Unified screw)	116-830	0.4 - 0.5mm/64 - 48TPI (116-831)
		0.6 - 0.9mm/44 - 28TPI (116-832)
		1 - 1.75mm/24 - 14TPI (116-833)
		2 - 3mm/13 - 9TPI (116-834)
		3.5 - 5mm/8 - 5TPI (116-835)
		5.5 - 7mm/4.5 - 3.5TPI (116-836)
Screw thread measurements (Whitworth screw)	116-840	60 - 48TPI (116-841)
		48 - 40TPI (116-842)
		40 - 32TPI (116-843)
		32 - 24TPI (116-844)
		24 - 18TPI (116-845)
		18 - 14TPI (116-846)
		14 - 10TPI (116-847)
		10 - 7TPI (116-848)
		7 - 4.5TPI (116-849)
		4.5 - 3.5TPI (116-850)

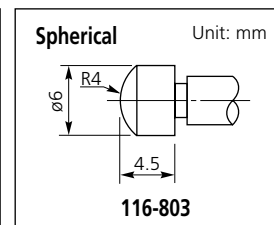
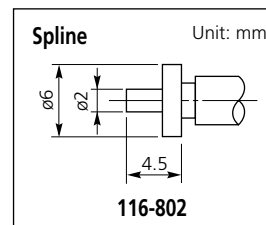
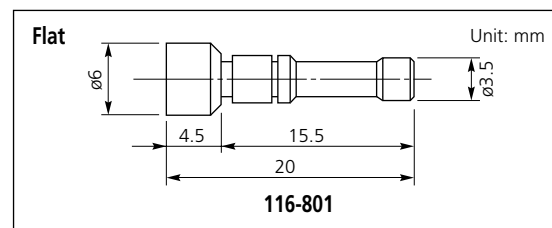
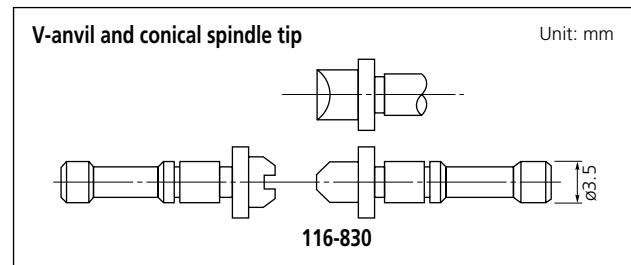

Interchangeable Anvils Set (Optional)

Applications	Order No.	Assortment of anvils
Multi-purpose measurements	116-800	Flat anvils (116-801)
		Spline anvils (116-802)
		Spherical anvils (116-803)
		Point anvils (116-804)
		Knife-edge anvils (116-805)
		Disk anvils (116-806)
		Blade anvils (116-807)

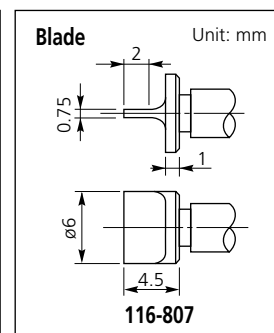
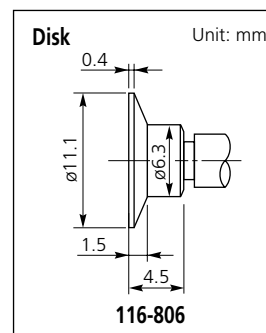
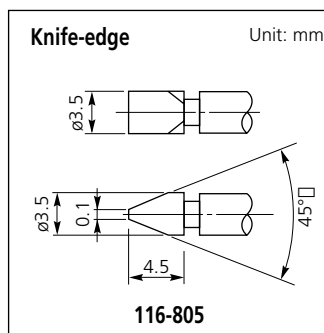
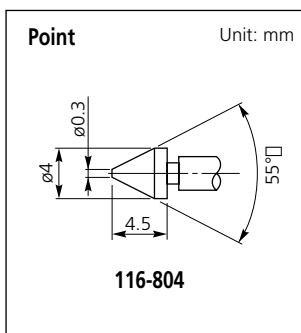

"Uni-Mike"

SERIES 317, 117 — Interchangeable Anvil Type



317-251

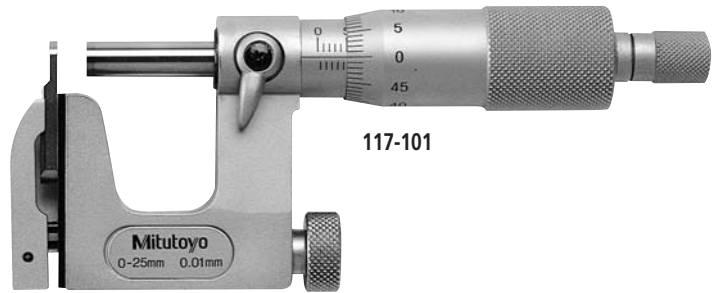

117-101

FEATURES

- IP65 water/dust protection level (317 series).
- Measures tubing thickness, shoulder-edge distance, rivet head height, etc. with interchangeable anvils (flat anvil, rod anvil, V-anvil).
- Supplied with Flat Anvil (**201216**) and Rod Anvil: $\varnothing 3\text{mm}$ rod anvil (**201217**) for 0-25mm (0-1") models, $\varnothing 5\text{mm}$ (**201379**) for 25-50mm (1"-2") model.
- With special Disk Anvils. The Uni-Mike is used as a height micrometer. The disks have a lapped, mirror surface.
- Provided with a standard except for 25mm (1") model.



Dimensions

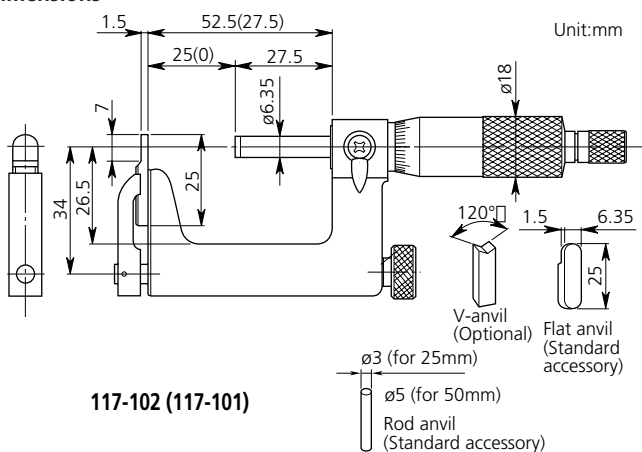

SPECIFICATIONS

Metric Digital model with ratchet stop

Range	Order No.	Resolution	Accuracy
0 - 25mm	317-251	0.001mm	$\pm 4\mu\text{m}$
25 - 50mm	317-252	0.001mm	$\pm 4\mu\text{m}$

Excluding quantizing error

Inch/Metric Digital model with friction thimble

Range	Order No.	Resolution	Accuracy
0 - 1"	317-351	0.0005"/0.001mm	$\pm .0002$ "
1" - 2"	317-352	0.0005"/0.001mm	$\pm .0002$ "

Excluding quantizing error

Metric With ratchet stop

Range	Order No.	Graduation	Accuracy
0 - 25mm	117-101	0.01mm	$\pm 4\mu\text{m}$
25 - 50mm	117-102	0.01mm	$\pm 4\mu\text{m}$

Inch With friction thimble

Range	Order No.	Graduation	Accuracy
0 - 1"	117-107	0.01"	$\pm .0002$ "
1" - 2"	117-108	0.01"	$\pm .0002$ "

Measuring faces

- Flatness: $0.6\mu\text{m}$ (.000024") for spindle face
 $2\mu\text{m}$ (.00008") for anvil face
- Parallelism: $3\mu\text{m}$ (.00012")

OPTIONAL ACCESSORIES

Order No.	Description
201218	V-anvil
950758	Disk anvil for 25mm (1") models
950759	Disk anvil for 50mm (2") models



Sheet Metal Micrometers

SERIES 389, 189, 119, 118

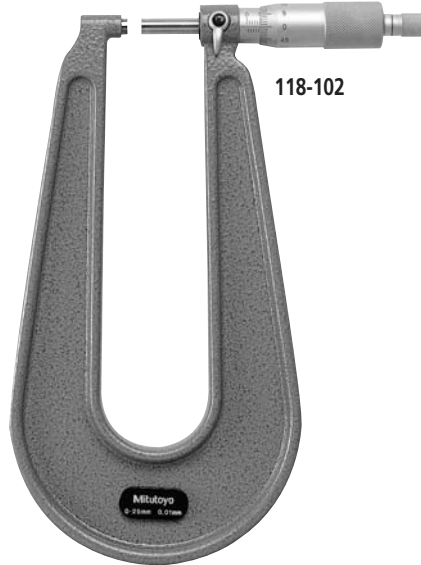

Anvil-Spindle Combinations

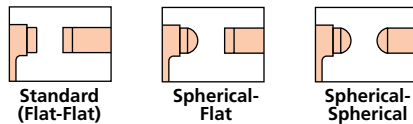

FEATURES

- Measures thickness of sheet metal, paper, plastic, and rubber parts.
- Carbide-tipped measuring faces.
- With Ratchet Stop for constant force.
- Provided with a standard except for 25mm (1") model.
- IP65 water/dust protection level (389 series*).
- *Except for 389-513
- The 189 series is provided with a digit counter.
- The 119 series is provided with a dial for making easy and quick reading.

SPECIFICATIONS

Metric		Digital model		
Range	Order No.	Resolution	Accuracy	Throat
0 - 25mm	389-251	0.001mm	±4µm	160mm
	389-261*	0.001mm	±4µm	160mm
	389-271**	0.001mm	±4µm	160mm
	389-513	0.001mm	±5µm	300mm
25 - 50mm	389-252	0.001mm	±4µm	165mm
	389-262*	0.001mm	±4µm	165mm
	389-272**	0.001mm	±4µm	165mm

*Spherical anvil and flat spindle

**Spherical anvil and spherical spindle

Excluding quantizing error

Inch/Metric		Digital model		
Range	Order No.	Resolution	Accuracy	Throat
0 - 1"	389-351	.00005"/0.001mm	±.0002"	6"
	389-361*	.00005"/0.001mm	±.0002"	6"
	389-371**	.00005"/0.001mm	±.0002"	6"
	389-713	.00005"/0.001mm	±.00025"	12"
1" - 2"	389-352	.00005"/0.001mm	±.0002"	6"
	389-362*	.00005"/0.001mm	±.0002"	6"
	389-372**	.00005"/0.001mm	±.0002"	6"

*Spherical anvil and flat spindle

**Spherical anvil and spherical spindle

Excluding quantizing error

Metric Mechanical counter model

Range	Order No.	Resolution	Accuracy	Throat
0 - 25mm	189-102	0.01mm	±4µm	150mm

Inch Mechanical counter model

Range	Order No.	Resolution	Accuracy	Throat
0 - 1"	189-129	.0001"	±.0002"	6"

Note: .0001" reading is obtained with vernier.

Metric

Range	Order No.	Graduation	Accuracy	Throat
0 - 25mm	118-101	0.01mm	±4µm	100mm
	118-102	0.01mm	±4µm	150mm
	118-114*	0.01mm	±4µm	150mm
	118-118**	0.01mm	±4µm	150mm
	118-103	0.01mm	±5µm	300mm
25 - 50mm	118-110	0.01mm	±4µm	150mm

*Spherical anvil and flat spindle

**Spherical anvil and spherical spindle

Inch

Range	Order No.	Graduation	Accuracy	Throat
0 - 1"	118-129	.0001"	±.0002"	6"
	118-116*	.0001"	±.0002"	6"
	118-120**	.0001"	±.0002"	6"
	118-107	.001"	±.00025"	12"
1" - 2"	118-112	.001"	±.0002"	6"

*Spherical anvil and flat spindle

**Spherical anvil and spherical spindle

Note: .0001" reading is obtained with vernier.

Metric Dial reading model

Range	Order No.	Resolution	Accuracy	Throat
0 - 25mm	119-202*	0.01mm	±4µm	50mm

*Spherical anvil and flat spindle

Measuring faces

- Flatness: 0.6µm (.000024") for models with 150mm(6") or less throat depth
1µm (.00004") for models with 300mm (12") throat depth
- Parallelism: 3µm (.00012")

Blade Micrometers

SERIES 422, 122 — Non-Rotating Spindle Type



422-111-30



122-101



FEATURES

- The anvil and the spindle have a blade for measuring the groove diameter of shafts, keyways, and other hard-to-reach portions.

Blade Dimensions

Unit: mm

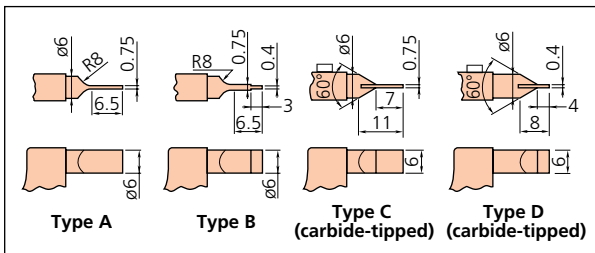

- With Ratchet Stop for constant force.
- Provided with a standard except for 25mm (1") model.

SPECIFICATIONS

Metric		Digital model		
Range	Order No.	Resolution	Accuracy	Remarks
0 - 25mm	422-111-30	0.001mm	±3μm	Type A
	422-141-30	0.001mm	±3μm	Type B
	422-121-30	0.001mm	±3μm	Type C
	422-151-30	0.001mm	±3μm	Type D
25 - 50mm	422-112-30	0.001mm	±3μm	Type A
	422-142-30	0.001mm	±3μm	Type B
50 - 75mm	422-113-30	0.001mm	±3μm	Type A
75 - 100mm	422-114-30	0.001mm	±4μm	Type A

Excluding quantizing error

Inch/Metric		Digital model		
Range	Order No.	Resolution	Accuracy	Remarks
0 - 1"	422-311-30	.00005"/0.001mm	±.00015"	Type A
	422-341-30	.00005"/0.001mm	±.00015"	Type B
	422-321-30	.00005"/0.001mm	±.00015"	Type C
	422-351-30	.00005"/0.001mm	±.00015"	Type D
1" - 2"	422-312-30	.00005"/0.001mm	±.00015"	Type A
	422-342-30	.00005"/0.001mm	±.00015"	Type B
2" - 3"	422-313-30	.00005"/0.001mm	±.00015"	Type A
3" - 4"	422-314-30	.00005"/0.001mm	±.0002"	Type A

Excluding quantizing error

Metric				
Range	Order No.	Graduation	Accuracy	Remarks
0 - 25mm	122-101	0.01mm	±3μm	Type A
	122-111	0.01mm	±3μm	Type B
	122-161	0.01mm	±3μm	Type C
	122-141	0.01mm	±3μm	Type D
25 - 50mm	122-102	0.01mm	±3μm	Type A
	122-112	0.01mm	±3μm	Type B
	122-162	0.01mm	±3μm	Type C
	122-142	0.01mm	±3μm	Type D
50 - 75mm	122-103	0.01mm	±3μm	Type A
75 - 100mm	122-104	0.01mm	±4μm	Type A
100 - 125mm	122-105	0.01mm	±4μm	Type A
125 - 150mm	122-106	0.01mm	±4μm	Type A
150 - 175mm	122-107	0.01mm	±5μm	Type A
175 - 200mm	122-108	0.01mm	±5μm	Type A

Inch				
Range	Order No.	Graduation	Accuracy	Remarks
0 - 1"	122-125	.0001"	±.00015"	Type A
	122-135	.0001"	±.00015"	Type B
	122-151	.0001"	±.00015"	Type D
1" - 2"	122-126	.0001"	±.00015"	Type A
	122-136	.0001"	±.00015"	Type B
2" - 3"	122-127	.0001"	±.00015"	Type A
3" - 4"	122-128	.0001"	±.0002"	Type A

Measuring faces

- Parallelism: 3μm (.00012") for models up to 50mm (2") (3+L/100)μm [(0.00012+0.00004 (L/4))"] for models over 50mm (2")*

* L=Maximum measuring length (mm) [(inch)], Fraction rounded up



Disk Micrometers

SERIES 323, 223, 123



323-511-30

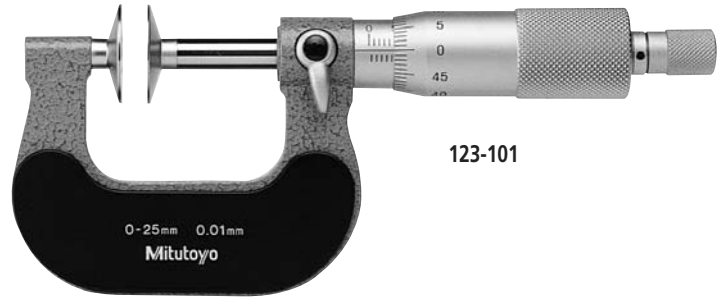

123-101

MICROMETERS

FEATURES

- The Disk Micrometer is designed to easily measure root tangent length of spur gears and herical gears.
- Diameter of measuring disk: 20mm (.79")
- 0.7mm edge thickness to enter narrow recesses.
- With Ratchet Stop for constant force.
- Provided with a standard except for 25mm (1") model.
- The 323 series (LCD readout type) is provided with SPC output.
- The 223 series is provided with a mechanical digit counter for quick reading of measurements.

SPECIFICATIONS

Metric		Digital model	
Range	Order No.	Resolution	Accuracy
0 - 25mm	323-511-30	0.001mm	±4μm
25 - 50mm	323-512-30	0.001mm	±4μm
50 - 75mm	323-513-30	0.001mm	±6μm
75 - 100mm	323-514-30	0.001mm	±6μm

Excluding quantizing error

Inch/Metric		Digital model	
Range	Order No.	Resolution	Accuracy
0 - 1"	323-711-30	.00005"/0.001mm	±.0002"
1" - 2"	323-712-30	.00005"/0.001mm	±.0002"
2" - 3"	323-713-30	.00005"/0.001mm	±.0003"
3" - 4"	323-714-30	.00005"/0.001mm	±.0003"

Excluding quantizing error

Metric		Mechanical counter model	
Range	Order No.	Resolution	Accuracy
0 - 25mm	223-101	0.01mm	±4μm
25 - 50mm	223-102	0.01mm	±4μm

Inch		Mechanical counter model	
Range	Order No.	Resolution	Accuracy
0 - 1"	223-125	.001"	±.0002"

Metric

Range	Order No.	Graduation	Accuracy
0 - 25mm	123-101	0.01mm	±4μm
	123-113*	0.01mm	±4μm
25 - 50mm	123-102	0.01mm	±4μm
	123-114*	0.01mm	±4μm
50 - 75mm	123-103	0.01mm	±6μm
	123-115*	0.01mm	±6μm
75 - 100mm	123-104	0.01mm	±6μm
	123-116*	0.01mm	±6μm
100 - 125mm	123-105	0.01mm	±7μm
125 - 150mm	123-106	0.01mm	±7μm
150 - 175mm	123-107	0.01mm	±8μm
175 - 200mm	123-108	0.01mm	±8μm
200 - 225mm	123-109	0.01mm	±8μm
225 - 250mm	123-110	0.01mm	±9μm
250 - 275mm	123-111	0.01mm	±9μm
275 - 300mm	123-112	0.01mm	±9μm

*The measuring disks have carbide tips.
Note: The disk diameter of models over 100mm is 30mm.

Inch

Range	Order No.	Graduation	Accuracy
0 - 1"	123-125	.001"	±.0002"
1" - 2"	123-126	.001"	±.0002"
2" - 3"	123-127	.001"	±.0003"
3" - 4"	123-128	.001"	±.0003"

Measuring faces

- Flatness: 1μm (.00004") for models up to 100mm (4")
1.6μm for models over 100mm
- Parallelism: 4μm (.00016") for models up to 50mm (2")
(4+L/50)μm [(0.00016+.00004 (L/2))"]*
for models up to 100mm (4") over 50mm (2")
(5+L/75)μm* for models over 100mm

* L=Maximum measuring length (mm) [(inch)], Fraction rounded up

Dimensions

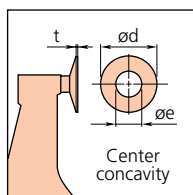

Unit: mm

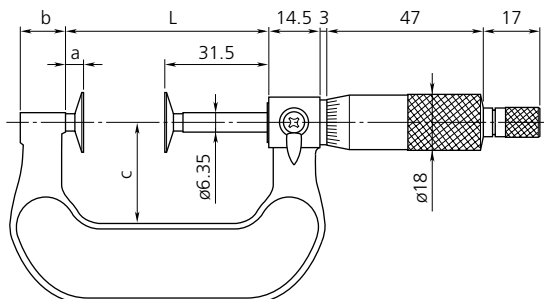

TECHNICAL INFORMATION

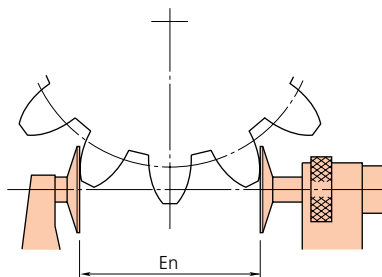

En = Root tangent length
 Note: Root tangent length measurement is not available for some types of gears.

Range	L	a	b	c	d	e	t
0 - 25mm	37.5	6	14	25	20	8 (9.8)	0.7
25 - 50mm	62.5	6	14	32	20	8 (9.8)	0.7
50 - 75mm	87	5.5	11	49	20	8 (9.8)	0.7
75 - 100mm	112	5.5	11	63	20	8 (9.8)	0.7
100 - 125mm	137.5	6	12	79	30	12	1
125 - 150mm	162.5	6	15	94	30	12	1
150 - 175mm	187.5	6	16	106	30	12	1
175 - 200mm	212.5	6	15	118	30	12	1
200 - 225mm	237.5	6	14	130	30	12	1
225 - 250mm	262.5	6	14	143	30	12	1
250 - 275mm	287.5	6	15	156	30	12	1
275 - 300mm	312.5	6	15	169	30	12	1

Data in () applies to those with carbide tipped disks.

Paper Thickness Micrometers

SERIES 169

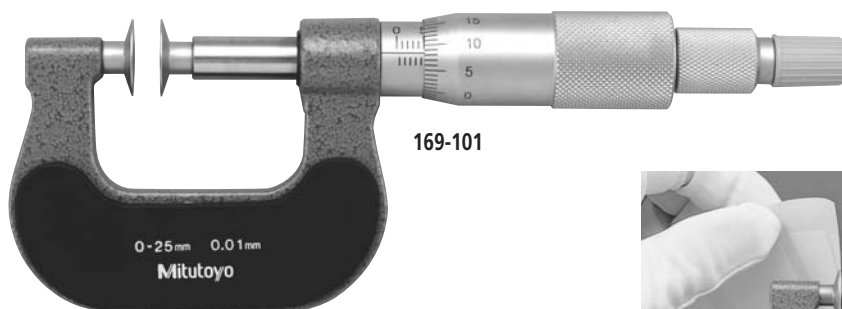

169-101



FEATURES

- Designed to measure paper thickness.
- Non-rotating spindle.
- With Ratchet Stop for constant force.

SPECIFICATIONS

Metric			
Range	Order No.	Graduation	Accuracy
0 - 25mm	169-101	0.01mm	±4µm

Inch			
Range	Order No.	Graduation	Accuracy
0 - 1"	169-103	.001"	±.0002"

Measuring faces

- Flatness: 1µm (.00004")
- Parallelism: 3µm (.00012")
- Dimensions

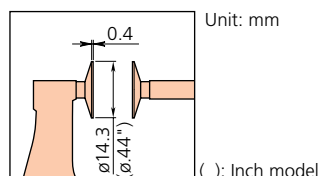

Disk Micrometers

SERIES 369, 169 — Non-Rotating Spindle Type



369-511-30

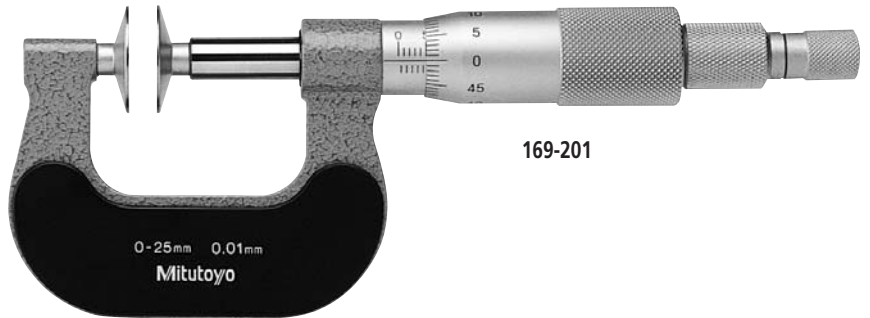

169-201

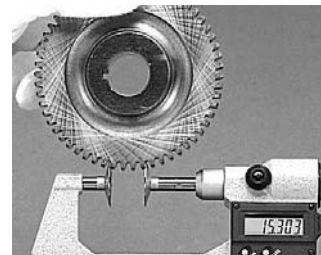

FEATURES

- Non-rotating spindle eliminates torque on workpiece.
- Diameter of measuring disk: 20mm (.79")
- With Ratchet Stop for constant force.
- Provided with a standard except for 25mm (1") model.
- The 369 series (LCD readout type) is provided with SPC output.

SPECIFICATIONS

Metric	Digital model	Range	Order No.	Resolution	Accuracy
		0 - 25mm	369-511-30	0.001mm	±4μm
		25 - 50mm	369-512-30	0.001mm	±4μm
		50 - 75mm	369-513-30	0.001mm	±6μm
		75 - 100mm	369-514-30	0.001mm	±6μm

Excluding quantizing error

Inch/Metric	Digital model	Range	Order No.	Resolution	Accuracy
		0 - 1"	369-711-30	.00005"/0.001mm	±.0002"
		1" - 2"	369-712-30	.00005"/0.001mm	±.0002"
		2" - 3"	369-713-30	.00005"/0.001mm	±.0003"
		3" - 4"	369-714-30	.00005"/0.001mm	±.0003"

Excluding quantizing error

Metric	Range	Order No.	Graduation	Accuracy
	0 - 25mm	169-201	0.01mm	±4μm
	25 - 50mm	169-202	0.01mm	±4μm
	50 - 75mm	169-205	0.01mm	±6μm
	75 - 100mm	169-207	0.01mm	±6μm

Inch	Range	Order No.	Graduation	Accuracy
	0 - 1"	169-203	.001"	±.0002"
	1" - 2"	169-204	.001"	±.0002"
	2" - 3"	169-206	.001"	±.0003"
	3" - 4"	169-208	.001"	±.0003"

Measuring faces

- Flatness: 1μm (.00004")
- Parallelism: 4μm (.00016") for models up to 50mm (2")
6μm (.00024") for models over 50mm (2")

Dimensions

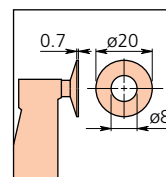

Unit: mm

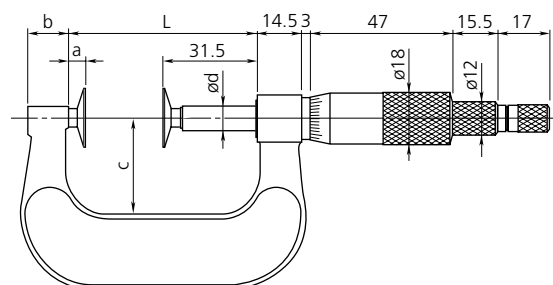

Range	L	a	b	c	d
0 - 25mm	37.5	6	13.5	25	8
25 - 50mm	62.5	6	13.5	32	8
50 - 75mm	87	5.5	13	49.5	8
75 - 100mm	112	5.5	13	63.5	8

Screw Thread Micrometers

SERIES 125



125-103

FEATURES

- Provided with a 60 degree V-anvil and conical spindle for easily measuring pitch diameters of metric or unified screw threads.
- With Ratchet Stop for constant force.
- With a standard for zero point adjustment.

Accuracy

- $\pm(2+L/75)\mu\text{m}^*$

*L=Maximum measuring length (mm), Fraction rounded up

Dimensions

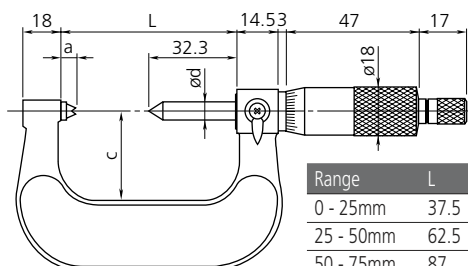

Range	L	a	c	d
0 - 25mm	37.5	5.2	25	6.35
25 - 50mm	62.5	5.2	32	6.35
50 - 75mm	87	4.7	49.5	6.35
75 - 100mm	112	4.7	63.5	6.35

SPECIFICATIONS

Metric			
Range	Order No.	Graduation	Screw to be measured (Metric/Unified)
0 - 25mm	125-101	0.01mm	0.4 - 0.5mm/64 - 48TPI
	125-102	0.01mm	0.6 - 0.9mm/44 - 28TPI
	125-103	0.01mm	1 - 1.75mm/24 - 14TPI
	125-104	0.01mm	2 - 3mm/13 - 9TPI
	125-105	0.01mm	3.5 - 5mm/8 - 5TPI
25 - 50mm	125-106	0.01mm	0.4 - 0.5mm/64 - 48TPI
	125-107	0.01mm	0.6 - 0.9mm/44 - 28TPI
	125-108	0.01mm	1 - 1.75mm/24 - 14TPI
	125-109	0.01mm	2 - 3mm/13 - 9TPI
	125-110	0.01mm	3.5 - 5mm/8 - 5TPI
50 - 75mm	125-111	0.01mm	0.6 - 0.9mm/44 - 28TPI
	125-112	0.01mm	1 - 1.75mm/24 - 14TPI
	125-113	0.01mm	2 - 3mm/13 - 9TPI
	125-114	0.01mm	3.5 - 5mm/8 - 5TPI
	125-115	0.01mm	5.5 - 7mm/4.5 - 3.5TPI
75 - 100mm	125-116	0.01mm	0.6 - 0.9mm/44 - 28TPI
	125-117	0.01mm	1 - 1.75mm/24 - 14TPI
	125-118	0.01mm	2 - 3mm/13 - 9TPI
	125-119	0.01mm	3.5 - 5mm/8 - 5TPI
	125-120	0.01mm	5.5 - 7mm/4.5 - 3.5TPI



Gear Tooth Micrometers

SERIES 324, 124 — Interchangeable Ball Anvil-Spindle Tip Type

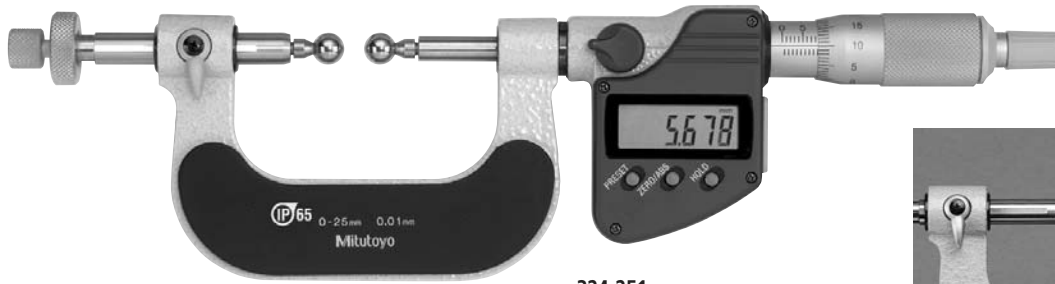

324-251



124-173

FEATURES

- IP65 water/dust protection level (324 series).
- Measures over-pin diameter of gears with precision steel (carbide) ball-tipped measuring faces.
- Interchangeable ball anvil-spindle tips for various gear modules (0.5 - 5.25) are optional.
- With Ratchet Stop for constant force.
- Provided with a standard except for 25mm (1") model.

SPECIFICATIONS

Metric	Digital model		
Range	Order No.	Resolution	Accuracy
0 - 25mm	324-251	0.001mm	±4μm
25 - 50mm	324-252	0.001mm	±4μm
50 - 75mm	324-253	0.001mm	±4μm
75 - 100mm	324-254	0.001mm	±5μm

Excluding quantizing error

Inch/Metric	Digital model		
Range	Order No.	Resolution	Accuracy
0 - 1"	324-351	.00005"/0.001mm	±.0002"
1" - 2"	324-352	.00005"/0.001mm	±.0002"
2" - 3"	324-353	.00005"/0.001mm	±.0002"
3" - 4"	324-354	.00005"/0.001mm	±.00025"

Excluding quantizing error

Metric			
Range	Order No.	Resolution	Accuracy
0 - 25mm	124-173	0.01mm	±4μm
25 - 50mm	124-174	0.01mm	±4μm
50 - 75mm	124-175	0.01mm	±4μm
75 - 100mm	124-176	0.01mm	±5μm
100 - 125mm	124-177	0.01mm	±5μm
125 - 150mm	124-178	0.01mm	±5μm
150 - 175mm	124-179	0.01mm	±6μm
175 - 200mm	124-180	0.01mm	±6μm
200 - 225mm	124-181	0.01mm	±6μm
225 - 250mm	124-182	0.01mm	±7μm
250 - 275mm	124-183	0.01mm	±7μm
275 - 300mm	124-195	0.01mm	±7μm



Interchangeable Ball Anvil-Spindle Tips (Optional)

Diameter	Order No.	Gears to be measured Module	Diametral pitch
0.8mm	124-801*	0.5 - 0.55	50
1mm	124-802*	0.6 - 0.65	45
1.191mm (3/64")	124-803*	0.7 - 0.8	35 - 30
1.5mm	124-821*	0.9 - 1	28 - 26
1.588mm (1/16")	124-804*	0.9 - 1	28 - 26
2mm	124-805	1.25	22
2.381mm (3/32")	124-806	1.5	17
2.5mm	124-822	1.5	17
3mm	124-807	1.75	15
3.175mm (1/8")	124-808	—	14
3.5mm	124-823	2	13
3.969mm (5/32")	124-809	2	13
4mm	124-810	2.25	11
4.5mm	124-824	2.5	10
4.763mm (3/16")	124-811	2.5	10
5mm	124-812	2.75	9
5.556mm (7/32")	124-813	3.0 - 3.25	8
6mm	124-814	3.5	7
6.35mm (1/4")	124-815	3.75	7
7mm	124-816	4.0	6.5
7.144mm (9/32")	124-817	4.25	6
7.938mm (5/16")	124-818	4.5	5.5
8mm	124-819	4.75	5.5
8.731mm (11/32")	124-820	5.0 - 5.25	5

*Carbide-tipped anvil

Screw Thread Micrometers

SERIES 326, 126 — Interchangeable Anvil-Spindle Tip Type



326-251

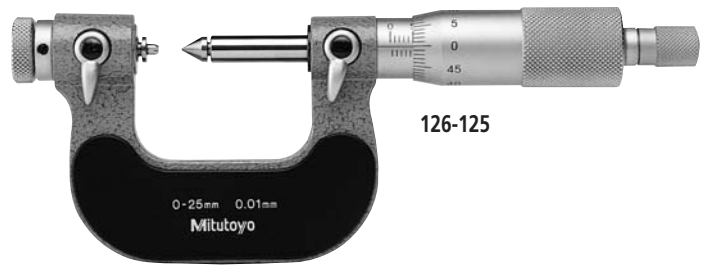

126-125

FEATURES

- IP65 water/dust protection level (326 series).
- 60 degree or 55 degree V-anvil and conical spindle (interchangeable) are optional, which are made of high-grade special steel, hardened and precision ground.

Application	Order No.	Assortment of anvil-spindle tips
Metric screw, Unified screw (60° threads)	126-800	0.4 - 0.5mm/64 - 48TPI (126-801) 0.6 - 0.9mm/44 - 28TPI (126-802) 1 - 1.75mm/24 - 14TPI (126-803) 2 - 3mm/13 - 9TPI (126-804) 3.5 - 5mm/8 - 5TPI (126-805) 5.5 - 7mm/4.5 - 3.5TPI (126-806)
Whitworth screw (55° threads)	126-810	60 - 48TPI (126-811) 48 - 40TPI (126-812) 40 - 32TPI (126-813) 32 - 24TPI (126-814) 24 - 18TPI (126-815) 18 - 14TPI (126-816) 14 - 10TPI (126-817) 10 - 7TPI (126-818) 7 - 4.5TPI (126-819) 4.5 - 3.5TPI (126-820)

- Provided with Ratchet Stop for constant force.
- Provided with a standard except for 25mm (1") model.
- The 326 series (LCD readout type) is provided with SPC output.

SPECIFICATIONS

Metric Digital model			
Range	Order No.	Resolution	Accuracy
0 - 25mm	326-251	0.001mm	±4μm
25 - 50mm	326-252	0.001mm	±4μm
50 - 75mm	326-253	0.001mm	±4μm
75 - 100mm	326-254	0.001mm	±5μm

Excluding quantizing error

Inch/Metric Digital model			
Range	Order No.	Resolution	Accuracy
0 - 1"	326-351	.00005"/0.001mm	±.0002"
1" - 2"	326-352	.00005"/0.001mm	±.0002"
2" - 3"	326-353	.00005"/0.001mm	±.0002"
3" - 4"	326-354	.00005"/0.001mm	±.00025"

Excluding quantizing error

Metric			
Range	Order No.	Graduation	Accuracy
0 - 25mm	126-125	0.01mm	±4μm
25 - 50mm	126-126	0.01mm	±4μm
50 - 75mm	126-127	0.01mm	±4μm
75 - 100mm	126-128	0.01mm	±5μm
100 - 125mm	126-129	0.01mm	±5μm
125 - 150mm	126-130	0.01mm	±5μm
150 - 175mm	126-131	0.01mm	±6μm
175 - 200mm	126-132	0.01mm	±6μm
200 - 225mm	126-133	0.01mm	±6μm
225 - 250mm	126-134	0.01mm	±7μm
250 - 275mm	126-135	0.01mm	±7μm
275 - 300mm	126-136	0.01mm	±7μm

Inch			
Range	Order No.	Graduation	Accuracy
1"	126-137	.001"	±.0002"
1" - 2"	126-138	.001"	±.0002"
2" - 3"	126-139	.001"	±.0002"
3" - 4"	126-140	.001"	±.00025"

(Models with a range up to 12" are available.)

Standards for Screw Thread Micrometers (Optional)

Metric			Inch		
Size	Order No. V=60°	Order No. V=55°	Size	Order No. V=60°	Order No. V=55°
25mm	167-261	167-272	1"	167-294	167-283
50mm	167-262	167-273	2"	167-295	167-284
75mm	167-263	167-274	3"	167-296	167-285
100mm	167-264	167-275	4"	167-297	167-286
125mm	167-265	167-276	5"	167-298	167-287
150mm	167-266	167-277	6"	167-299	167-288
175mm	167-267	167-278	7"	167-300	167-289
200mm	167-268	167-279	8"	167-301	167-290
225mm	167-269	167-280	9"	167-302	167-291
250mm	167-270	167-281	10"	167-303	167-292
275mm	167-271	167-282	11"	167-304	167-293



Can Seam Micrometers

SERIES 347, 147



147-103



147-202

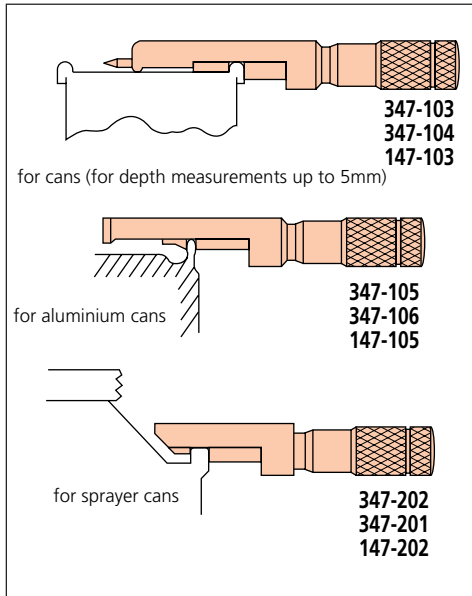

SPECIFICATIONS

Metric		Digital model	
Range	Order No.	Resolution	Remarks
0 - 13mm	347-103	0.001mm	for steel cans
	347-105	0.001mm	for aluminum cans
	347-202	0.001mm	for sprayer cans

Inch/Metric		Digital model	
Range	Order No.	Resolution	Remarks
0 - .5"	347-104	.00005"/0.001mm	for steel cans
	347-106	.00005"/0.001mm	for aluminum cans
	347-201	.00005"/0.001mm	for sprayer cans

FEATURES

- Measures the width, height, and depth of can seams.
- Three types of micrometers are available for : steel cans, aluminum cans, and sprayer cans.

Dimensions

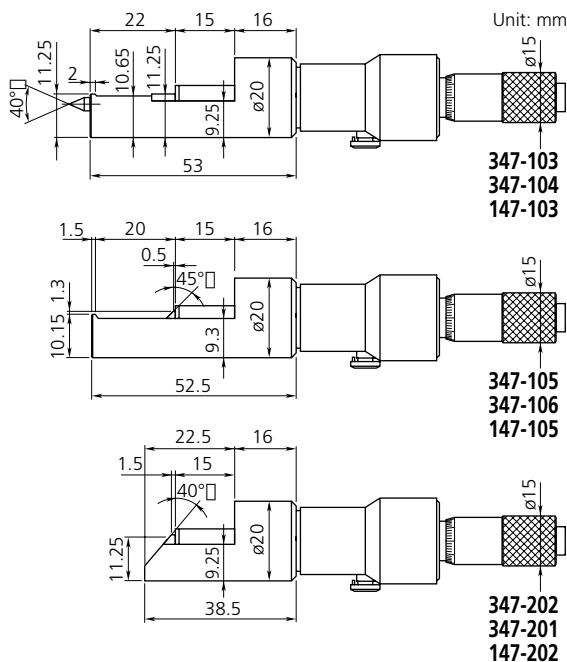

Metric			
Range	Order No.	Graduation	Remarks
0 - 13mm	147-103	0.01mm	for steel cans
	147-105	0.01mm	for aluminum cans
	147-202	0.01mm	for sprayer cans

Inch			
Range	Order No.	Graduation	Remarks
0 - .5"	147-104	.001"	for steel cans
	147-106	.001"	for aluminum cans
	147-201	.001"	for sprayer cans

Accuracy

- $\pm 3\mu\text{m}$ ($\pm .00015"$)
Excluding quantizing error. (347 series)

Hub Micrometers

SERIES 147



147-301

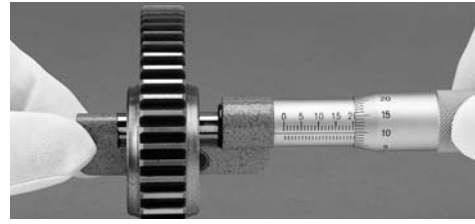

FEATURES

- Measures hub thickness and shoulders inside a bore.
- Carbide-tipped measuring faces.
- With Ratchet Stop for constant force.
- Provided with a standard except for 25mm (1") model.

SPECIFICATIONS

Metric

Range	Order No.	Graduation	Accuracy
0 - 25mm	147-301	0.01mm	±2μm
25 - 50mm	147-302	0.01mm	±2μm
50 - 75mm	147-303	0.01mm	±2μm
75 - 100mm	147-304	0.01mm	±3μm

Inch

Range	Order No.	Graduation	Accuracy
0 - 1"	147-351	.001"	±.0001"
1" - 2"	147-352	.001"	±.0001"
2" - 3"	147-353	.001"	±.0001"
3" - 4"	147-354	.001"	±.00015"

Measuring faces

- Flatness: 0.6μm (.000024")
 - Parallelism: $(2+L/100)\mu\text{m} [(.00008+.00004 (L/4))"]^*$
- *L=Maximum measuring length (mm) [(inch)], Fraction rounded up

Dimensions

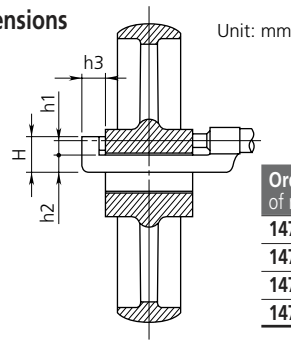

Order No. of micrometer	h1	h2	h3	H
147-301	6	8.5	13.5	17.5
147-302	6.5	11	14	20.5
147-303	6.5	11	13	20.5
147-304	6.5	11	13	20.5

Wire Micrometers

SERIES 147



147-401

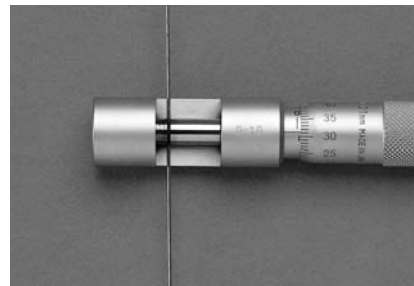

FEATURES

- Designed for measuring wire thickness.
- Also used to measure the diameter of a small ball.
- Carbide-tipped measuring faces

SPECIFICATIONS

Metric

Range	Order No.	Graduation	Accuracy
0 - 10mm	147-401	0.01mm	±3μm

Inch

Range	Order No.	Graduation	Accuracy
0 - .4"	147-402	.0001"	±.00015"

Note: .0001" reading is obtained with vernier.

Measuring faces

- Flatness: 0.6μm (.000024")
- Parallelism: 1.3μm (.00006")

Dimensions

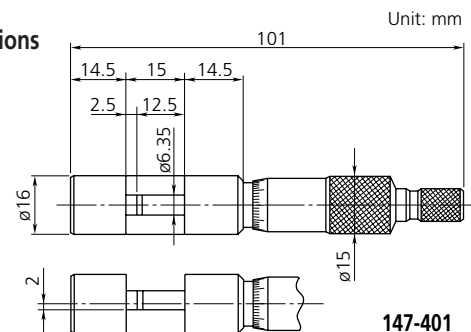

147-401



Digit Outside Micrometers

SERIES 193

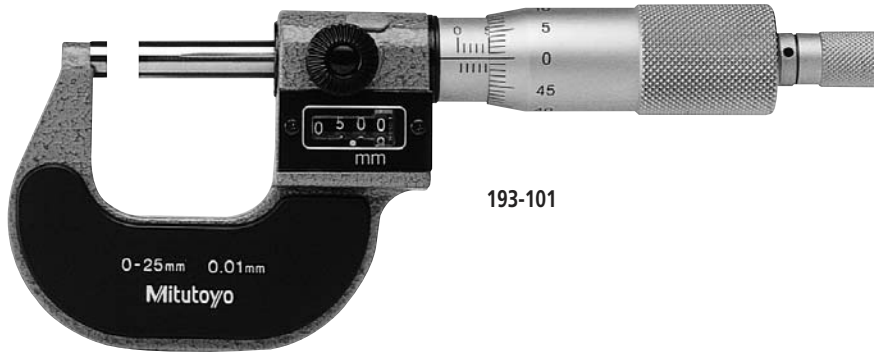

193-101

FEATURES

- Mechanical digit counter for quick and error-free reading.
- Direct readout on the counter to 0.01mm (.001").
- Carbide-tipped measuring faces for long life.
- Provided with a standard except for 25mm (1") model.

SPECIFICATIONS

Metric		With ratchet stop	
Range	Order No.	Graduation	Accuracy
0 - 25mm	193-101	0.01mm	±2μm
	193-111	0.001mm	±2μm
25 - 50mm	193-102	0.01mm	±2μm
	193-112	0.001mm	±2μm
50 - 75mm	193-103	0.01mm	±2μm
	193-113	0.001mm	±2μm
75 - 100mm	193-104	0.01mm	±3μm
	193-114	0.001mm	±3μm
100 - 125mm	193-305	0.01mm	±3μm
125 - 150mm	193-306	0.01mm	±3μm
150 - 175mm	193-307	0.01mm	±4μm
175 - 200mm	193-308	0.01mm	±4μm
200 - 225mm	193-309	0.01mm	±4μm
225 - 250mm	193-310	0.01mm	±5μm

Inch		With ratchet stop	
Range	Order No.	Graduation	Accuracy
2" - 3"	193-213	.0001"	±.0001"
3" - 4"	193-214	.0001"	±.00015"
4" - 5"	193-415	.0001"	±.00015"
5" - 6"	193-416	.0001"	±.00015"
6" - 7"	193-417	.0001"	±.0002"
7" - 8"	193-418	.0001"	±.0002"
8" - 9"	193-419	.0001"	±.0002"
9" - 10"	193-420	.0001"	±.00025"
10" - 11"	193-421	.0001"	±.00025"

Note: 0.001mm (.0001") reading is obtained with vernier.

Inch		With friction thimble	
Range	Order No.	Graduation	Accuracy
0 - 1"	193-201	.001"	±.0001"
	193-211	.0001"	±.0001"
1" - 2"	193-202	.001"	±.0001"
	193-212	.0001"	±.0001"

Note: .0001" reading is obtained with vernier.

Measuring faces

- Flatness: 0.6μm (.000024") for models up to 300mm (12")
- Parallelism: $(2+L/100)\mu\text{m}$ [$(.00008+.00004(L/4))$ "]*
*L=Maximum measuring length (mm) [(inch)], Fraction rounded down.

Dimensions

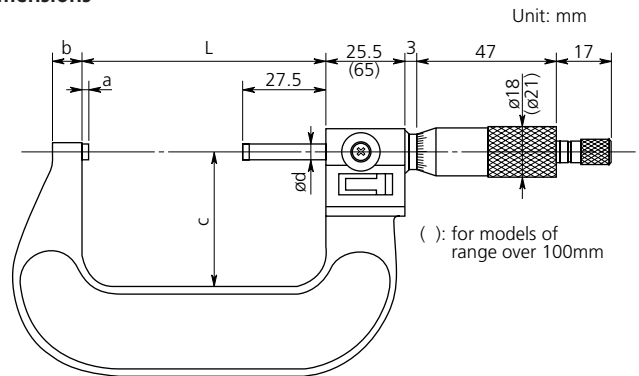

Range	L	a	b	c	d
0 - 25mm	30	2.5	5	26	6.35
25 - 50mm	55	2.5	8	32	6.35
50 - 75mm	80	2.5	9	45	6.35
75 - 100mm	105	2.5	9	57	6.35
100 - 125mm	137	6	18	80	8
125 - 150mm	162	6	18	93	8
150 - 175mm	187	6	18	106	8
175 - 200mm	212	6	19	119	8
200 - 225mm	238	7	20	132	8
225 - 250mm	263	7	19	145	8
250 - 275mm	289	8	19	158	8
275 - 300mm	314	8	20	171	8

Note: The shape of the thimble changes on the model with Friction Thimble.

Metric Micrometer set		
Range	Order No.	Assortment of micrometers
0 - 75mm (3 mikes/set)	193-901	• 193-101, 193-102, 193-103 • 2 micrometer standards
0 - 100mm (4 mikes/set)	193-902	• 193-101, 193-102, 193-103, 193-104 • 3 micrometer standards
0 - 150mm (6 mikes/set)	193-908	• 193-101, 193-102, 193-103, 193-104, 193-305, 193-306 • 5 micrometer standards

Inch Micrometer set		
Range	Order No.	Assortment of micrometers
0 - 3" (3 mikes/set)	193-923	• 193-211, 193-212, 193-213 • 2 micrometer standards
0 - 6" (6 mikes/set)	193-930	• 193-211, 193-212, 193-213, 193-214, 193-415, 193-416 • 5 micrometer standards

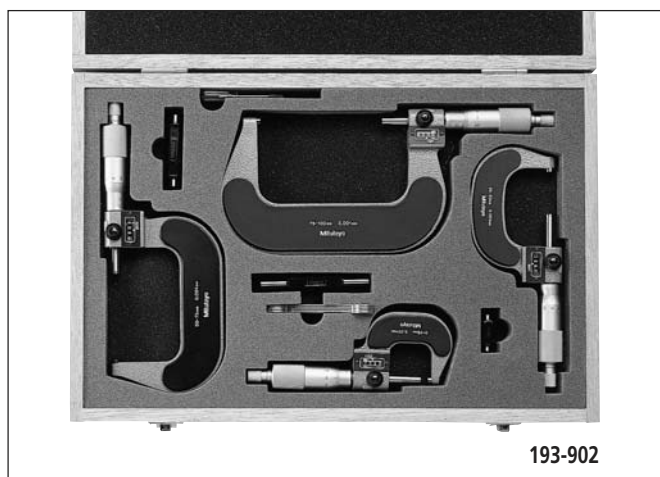

193-902

Caliper Type Micrometers

SERIES 343, 143



343-511-30

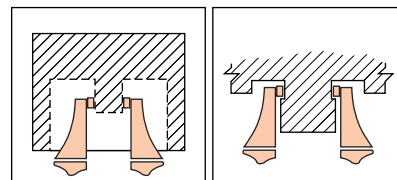

FEATURES

- Carbide-tipped measuring faces.
- With Ratchet Stop for constant force.
- Provided with a standard except for 25mm (1") model.

SPECIFICATIONS

Metric Digital model			
Range	Order No.	Resolution	Accuracy
0 - 25mm	343-511-30	0.001mm	±5μm
25 - 50mm	343-512-30	0.001mm	±6μm
50 - 75mm	343-513-30	0.001mm	±7μm
75 - 100mm	343-514-30	0.001mm	±8μm

Excluding quantizing error

Inch/Metric Digital model			
Range	Order No.	Resolution	Accuracy
0 - 1"	343-711-30	.00005"/0.001mm	±.00025"
1" - 2"	343-712-30	.00005"/0.001mm	±.0003"
2" - 3"	343-713-30	.00005"/0.001mm	±.00035"
3" - 4"	343-714-30	.00005"/0.001mm	±.0004"

Excluding quantizing error

Metric			
Range	Order No.	Graduation	Accuracy
0 - 25mm	143-101	0.01mm	±5μm
25 - 50mm	143-102	0.01mm	±6μm
50 - 75mm	143-103	0.01mm	±7μm
75 - 100mm	143-104	0.01mm	±8μm
100 - 125mm	143-105	0.01mm	±9μm

Models with a range up to 300mm are available.

Inch			
Range	Order No.	Graduation	Accuracy
0 - 1"	143-121	.001"	±.00025"
1" - 2"	143-122	.001"	±.0003"

Models with a range up to 4" are available.

Measuring faces

- Flatness: 0.3μm (.000012")
- Parallelism: (3+L/75)μm [(0.0012+.00004 (L/3))"]*

* L=Maximum measuring length (mm) [(inch)], Fraction rounded down

Digimatic Micrometers

SERIES 227 — with Constant & Adjustable Fine-loading Device



227-203



227-201



227-221

MICROMETERS

FEATURES

- Constant and low measuring force mechanism in the thimble.
- Adjustable measuring force* accommodates various kind of work materials. *0.5-2.5N or 2-10N



Plastic pipe

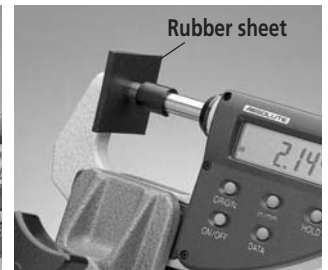

Rubber sheet

- The measurement-value hold function automatically retains the data at a specified measuring force, ensuring accuracy.
- Large LCD digits of 7.5mm height for error-free reading.
- Non-rotating spindle and the new ratchet friction thimble.
- Speedy spindle feed of 10 mm/.4".
- With absolute linear scale.
- The IP54 level water resistance protection (when not connected with data output cable).
- With SPC data output.
- With a standard bar to set the origin point (for models with 15 - 30mm range).

SPECIFICATION

Metric

Range	Order No.	Resolution	Accuracy	Measuring force
0 - 15mm	227-201	0.001mm	±2μm	0.5N - 2.5N
	227-202	0.001mm	±2μm	2N - 10N
15 - 30mm	227-203	0.001mm	±2μm	0.5N - 2.5N
	227-204	0.001mm	±2μm	2N - 10N

Excluding quantizing error

Inch/Metric

Range	Order No.	Resolution	Accuracy	Measuring force
0 - .6"	227-211	.00005"/0.001mm	±.0001"	0.5N - 2.5N
	227-212	.00005"/0.001mm	±.0001"	2N - 10N
.6" - 1.2"	227-213	.00005"/0.001mm	±.0001"	0.5N - 2.5N
	227-214	.00005"/0.001mm	±.0001"	2N - 10N

Excluding quantizing error

Metric Disk type

Range	Order No.	Resolution	Accuracy	Measuring force
0 - 15mm	227-221	0.001mm	±4μm	0.5N - 2.5N
	227-222	0.001mm	±4μm	2N - 10N

Excluding quantizing error

Inch/Metric Disk type

Range	Order No.	Resolution	Accuracy	Measuring force
0 - .6"	227-231	.00005"/0.001mm	±.0002"	0.5N - 2.5N
	227-232	.00005"/0.001mm	±.0002"	2N - 10N

Excluding quantizing error

Dimensions

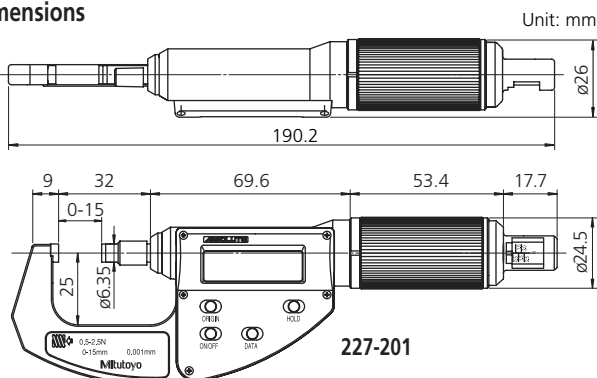

227-201

Low Force Micrometers

SERIES 227



227-101

FEATURES

- Low Force Micrometers are specially designed for elastic workpieces such as plastic parts.
- Constant measuring force of 1N is ensured by the spring-loaded anvil.
- The spindle does not rotate.
- With a friction thimble.
- Carbide-tipped measuring faces.
- Provided with a standard to set the origin point for 25-50mm model.

SPECIFICATION

Metric				
Range	Order No.	Graduation	Accuracy	Mass
0 - 25mm	227-101	0.01mm	±2µm	262g
25 - 50mm	227-102	0.01mm	±2µm	290g

Inch				
Range	Order No.	Graduation	Accuracy	Mass
0 - 1"	227-111	.0001"	±.0001"	.58 lbs.

Technical Data

Measuring faces: Carbide-tipped
 Flatness of measuring faces: 0.6µm
 Parallelism between measuring faces: 3µm
 Measuring force: 1N

Dimensions

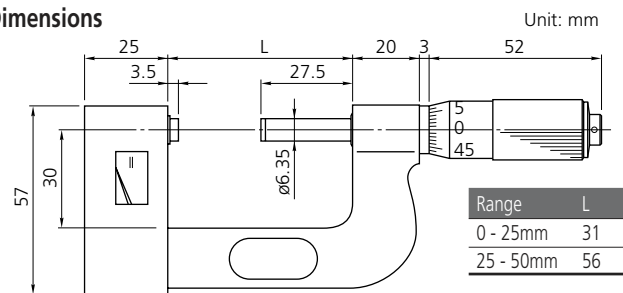

MICROMETERS



Digimatic Bench Micrometer

SERIES 121 — Interchangeable Anvil Type



121-145

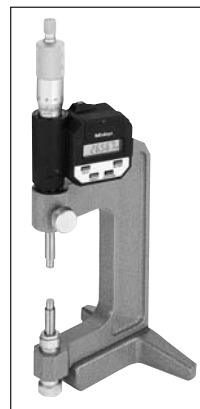

FEATURES

- The LCD panel rotates within 330 degrees for use in horizontal or vertical position.
- Interchangeable anvils allow a wide measuring range of 50mm (2").
- Provided with a ratchet stop for constant force.
- Provided with a standard to set the origin for 25-50mm measurement.

SPECIFICATION

Metric				
Range	Order No.	Resolution	Accuracy	Mass
0 - 50mm	121-145	0.001mm	±2µm	2.3kg

Excluding quantizing error

Inch/Metric				
Range	Order No.	Resolution	Accuracy	Mass
0 - 2"	121-155	.00005" / 0.001mm	±.0001"	5.07 lbs.

Excluding quantizing error

Technical Data

Display: LCD
 Functions: Zero-Set, presetting, power on/off, counting direction switching, inch/mm conversion (inch/mm type only), SPC data output
 Micrometer head stroke: 25mm (1")
 Measuring faces: Carbide-tipped
 Measuring force: 6N - 10N
 Battery: SR44 (2 pcs.) (938882 X 2 pcs.)
 Battery life: Approx. 1.8 years under normal use
 Alarm: Low battery voltage, over-speed error, over-flow error
 Operating temperature: 5°C to 40°C

OPTIONAL ACCESSORIES

Order No.	Description
937387	SPC cable (1m)
965013	SPC cable (2m)

Snap Meters

SERIES 523

MICROMETERS



523-141

Dimensions

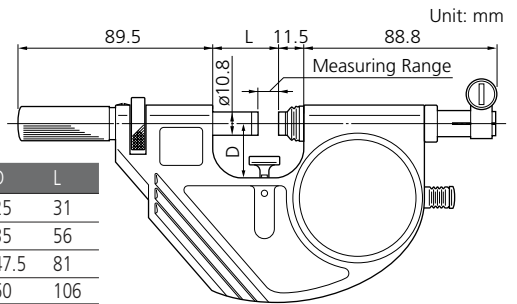

Range	D	L
0 - 25mm	25	31
25 - 50mm	35	56
50 - 75mm	47.5	81
75 - 100mm	60	106

Accuracy (dispersion of indication)
0.4μm (.00002")

Measuring faces

- Flatness: 0.3μm (.000015")
- Parallelism:
0.6μm (.00003") for models up to 50mm (2")
1μm (.00005") for models up to 100mm (4")

FEATURES

- Various types of indicator can be selected according to the measurement applications.
- Spindle diameter: 10.8mm (.425")
- Carbide-tipped measuring faces.
- Measuring force: 5 - 15N (500 - 1500gf)

SPECIFICATIONS

Metric		
Range	Order No.	Anvil movement
0 - 25mm	523-141	2mm
25 - 50mm	523-142	2mm
50 - 75mm	523-143	2mm
75 - 100mm	523-144	2mm

Inch		
Range	Order No.	Anvil movement
0 - 1"	523-115	.078"
1" - 2"	523-152	.078"
2" - 3"	523-153	.078"
3" - 4"	523-154	.078"

Dial Snap Meters

SERIES 523



523-101

SPECIFICATIONS

Metric			
Range	Order No.	Graduation of indicator	Indicating range
0 - 25mm	523-121	0.001mm	±0.060mm
25 - 50mm	523-122	0.001mm	±0.060mm
50 - 75mm	523-123	0.001mm	±0.060mm
75 - 100mm	523-124	0.001mm	±0.060mm

Inch			
Range	Order No.	Graduation of indicator	Indicating range
0 - 1"	523-131	.00005"	±.0023"
1" - 2"	523-132	.00005"	±.0023"
2" - 3"	523-133	.00005"	±.0023"
3" - 4"	523-134	.00005"	±.0023"

Accuracy

1μm (.00005") for ±0.060mm (±.0023") indicating range

Measuring faces

- Flatness: 0.3μm (.000015")
- Parallelism:
0.6μm (.00003") for models up to 50mm (2")
1μm (.00005") for models up to 100mm (4")

FEATURES

- Direct GO/NO-GO judgment for mass-produced parts.
- Spindle diameter: 10.8mm (.425")
- Carbide-tipped measuring faces.
- Measuring force: 6 - 15N (600 - 1500gf)
- IP protection level: 54



Indicating Micrometers

SERIES 510



FEATURES

- Retractable anvil with indicator for three-wire measurements of pitch diameter of precision screws, roundness and parallelism measurements.
- Spindle diameter: 8mm (.315")
- Carbide-tipped measuring faces.
- Measuring force: 5 - 15N (500 - 1500gf)
- Provided with a standard except for 25mm (1") model.
- IP protection level: 54

Accuracy

- Micrometer: $3\mu\text{m}$ (.00015")
- Indicator: $1\mu\text{m}$ (.00005")

Measuring faces

- Flatness: $0.3\mu\text{m}$ (.000015")
- Parallelism: $0.6\mu\text{m}$ (.00003") for models up to 50mm (2")
 $1\mu\text{m}$ (.00005") for models over 50mm (2")

SPECIFICATIONS

Metric

Range	Order No.	Graduation of indicator	Indicating range
0 - 25mm	510-121*	0.001mm	$\pm 0.060\text{mm}$
25 - 50mm	510-122	0.001mm	$\pm 0.060\text{mm}$
50 - 75mm	510-123	0.001mm	$\pm 0.060\text{mm}$
75 - 100mm	510-124	0.001mm	$\pm 0.060\text{mm}$

*510-151: Retractable anvil button on the left side.

Inch

Range	Order No.	Graduation of indicator	Indicating range
0 - 1"	510-131*	.00005"	$\pm .0023"$
1" - 2"	510-132	.00005"	$\pm .0023"$
2" - 3"	510-133	.00005"	$\pm .0023"$
3" - 4"	510-134	.00005"	$\pm .0023"$

*510-141: Retractable anvil button on the left side.

Dimensions

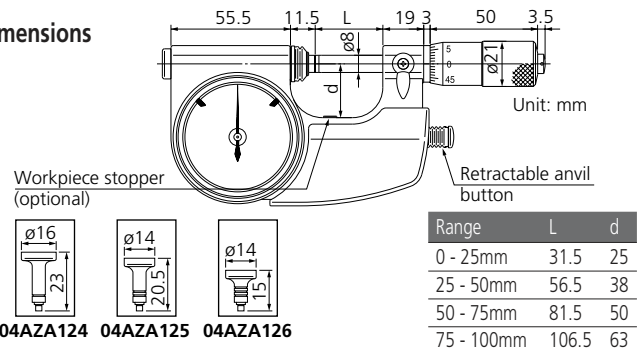

Outside Micrometers

SERIES 107



FEATURES

- With dial indicator for direct GO/NG-GO judgment for mass-produced parts.
- Anvil retracting trigger for quick measurement.
- Anvil retracting range: 4mm
- Carbide-tipped measuring faces.
- Provided with a standard except for 25mm model.



SPECIFICATIONS

Metric

Range	Order No.	Accuracy
0 - 25mm	107-201	$\pm 2\mu\text{m}$
25 - 50mm	107-202	$\pm 2\mu\text{m}$
50 - 75mm	193-203	$\pm 2\mu\text{m}$
75 - 100mm	107-204	$\pm 3\mu\text{m}$
100 - 125mm	172-205	$\pm 3\mu\text{m}$
125 - 150mm	172-206	$\pm 3\mu\text{m}$
150 - 175mm	172-207	$\pm 4\mu\text{m}$
175 - 200mm	172-208	$\pm 4\mu\text{m}$

Measuring faces

- Flatness: $0.6\mu\text{m}$
 - Parallelism: $(2+L/100)\mu\text{m}$
- *L=Maximum measuring length (mm), Fraction rounded down.

Dimensions

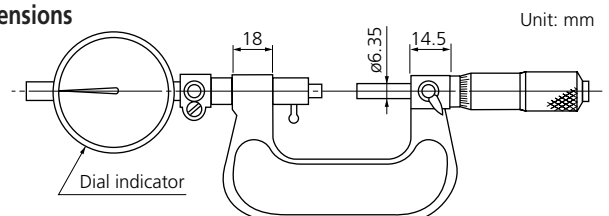

Limit Micrometers

SERIES 113

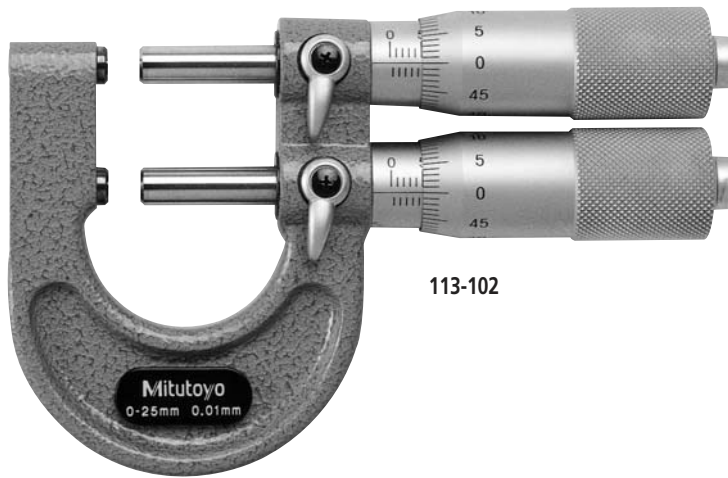

113-102

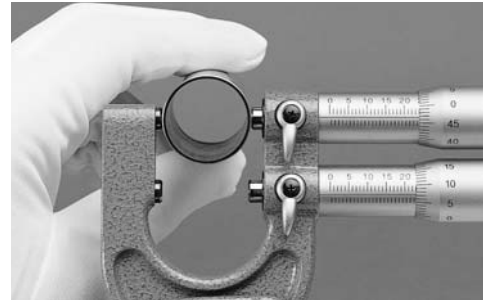

MICROMETERS

FEATURES

- Can be used as a GO/±NG gage by setting the upper and lower limits.
- Carbide-tipped measuring faces.
- Provided with a standard for 25mm - 50mm model.

SPECIFICATIONS

Metric

Range	Order No.	Graduation	Accuracy
0 - 25mm	113-102	0.01mm	±3μm
25 - 50mm	113-103	0.01mm	±3μm

Measuring faces

- Flatness: 0.6μm
 - Parallelism: $(3+L/100)\mu\text{m}^*$
- * L=Maximum measuring length (mm) Fraction rounded down

Optical Flats

SERIES 158



FEATURES

- Used for inspecting the flatness of micrometer's or gauge block's measuring faces with high accuracy.

SPECIFICATIONS

Metric			
Flatness	Order No.	Diameter	Thickness
0.2μm	158-117	45mm	12mm
	158-119	60mm	15mm
0.1μm	158-118	45mm	12mm
	158-120	60mm	15mm

TECHNICAL INFORMATION

Flatness Check of Measuring Faces Using Interference Fringe Pattern Produced by an Optical Flat

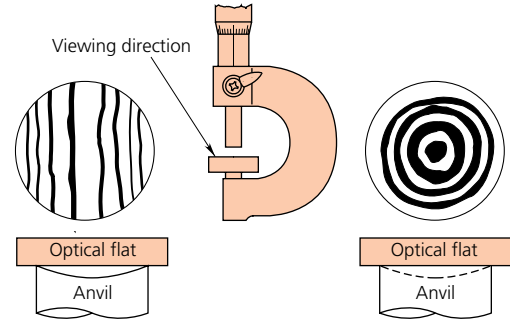

Inch			
Flatness	Order No.	Diameter	Thickness
.000004"	158-122	1.8"	.5"
	158-124	2.4"	.6"

MICROMETERS



Optical Parallels

SERIES 157



FEATURES

- Designed to inspect parallelism and flatness of measuring faces of micrometers.
- Each set consists of 4 thicknesses.
- Flatness: 0.1μm (.000004")
- Parallelism: 0.2μm (.000008")
- Diameter of optical parallel: 30mm (1.19")
- Supplied with fitted carrying case.

SPECIFICATIONS

Metric		
Range of micrometer to be checked	Order No.	Assortment of parallels (Thickness of parallel)
0-25mm	157-903	12.00, 12.12, 12.25, 12.37mm
25-50mm	157-904	25.00, 25.12, 25.25, 25.37mm

TECHNICAL INFORMATION

Parallelism Check between Measuring Faces by Means of Interference Fringe Produced by an Optical Parallel

The parallelism between the measuring faces can be determined as follows; bring the optical parallel to the anvil and observe the number of interference fringes produced on the spindle side under the measuring force of the micrometers.

The parallelism is about 1μm (0.32μm x 3 = 0.96μm). Fringe on the anvil side must not be more than one.

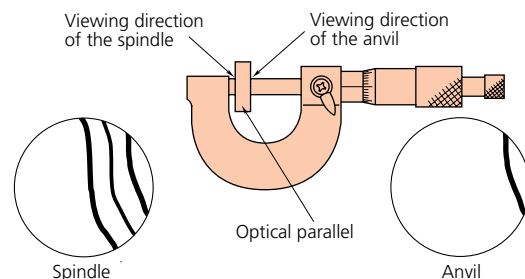

Inch		
Range of micrometer to be checked	Order No.	Assortment of parallels (Thickness of parallel)
0-1"	157-901	.5000", .5062", .5125", .5187"
1-2"	157-902	1.0000", 1.0062", 1.0125", 1.0187"

Micrometer Standards

SERIES 167



Technical Data

Flatness of measuring faces: $0.3\mu\text{m}$ (.000012")
 Parallelism between measuring faces: $2\mu\text{m}$ (.00008")

FEATURES

- Used for the zero point setting of outside micrometers.
- Flat and lapped measuring faces.
- Heat insulating handle for preventing expansion due to body temperature.



SPECIFICATIONS

Metric			Inch		
Length	Order No.	Diameter	Length	Order No.	Diameter
25mm	167-101	6.35mm	525mm	167-121	11.9mm
50mm	167-102	6.35mm	550mm	167-122	11.9mm
75mm	167-103	6.35mm	575mm	167-123	11.9mm
100mm	167-104	7.9mm	600mm	167-124	11.9mm
125mm	167-105	7.9mm	625mm	167-125	11.9mm
150mm	167-106	7.9mm	650mm	167-126	11.9mm
175mm	167-107	7.9mm	675mm	167-127	11.9mm
200mm	167-108	9.4mm	700mm	167-128	11.9mm
225mm	167-109	9.4mm	725mm	167-129	11.9mm
250mm	167-110	9.4mm	750mm	167-130	11.9mm
275mm	167-111	9.4mm	775mm	167-131	11.9mm
300mm	167-112	9.4mm	800mm	167-132	11.9mm
325mm	167-113	9.4mm	825mm	167-133	11.9mm
350mm	167-114	9.4mm	850mm	167-134	11.9mm
375mm	167-115	9.4mm	875mm	167-135	11.9mm
400mm	167-116	9.4mm	900mm	167-136	11.9mm
425mm	167-117	9.4mm	925mm	167-137	11.9mm
450mm	167-118	9.4mm	950mm	167-138	11.9mm
475mm	167-119	9.4mm	975mm	167-139	11.9mm
500mm	167-120	11.9mm	1000mm	167-140	11.9mm

Metric			Inch		
Length	Order No.	Diameter	Length	Order No.	Diameter
1"	167-141	.25"	21"	167-161	.47"
2"	167-142	.25"	22"	167-162	.47"
3"	167-143	.25"	23"	167-163	.47"
4"	167-144	.31"	24"	167-164	.47"
5"	167-145	.31"	25"	167-165	.47"
6"	167-146	.31"	26"	167-166	.47"
7"	167-147	.31"	27"	167-167	.47"
8"	167-148	.37"	28"	167-168	.47"
9"	167-149	.37"	29"	167-169	.47"
10"	167-150	.37"	30"	167-170	.47"
11"	167-151	.37"	31"	167-171	.47"
12"	167-152	.37"	32"	167-172	.47"
13"	167-153	.37"	33"	167-173	.47"
14"	167-154	.37"	34"	167-174	.47"
15"	167-155	.37"	35"	167-175	.47"
16"	167-156	.37"	36"	167-176	.47"
17"	167-157	.37"	37"	167-177	.47"
18"	167-158	.37"	38"	167-178	.47"
19"	167-159	.37"	39"	167-179	.47"
20"	167-160	.47"	40"	167-180	.47"

MICROMETERS



Standards for Screw Thread Micrometers

SERIES 167 — 60 degree and 55 degree



FEATURES

- Specially designed for the zero point setting of screw thread micrometers.

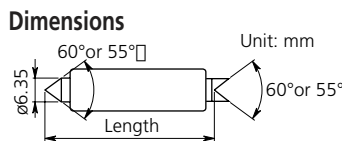

SPECIFICATIONS

Metric			Inch		
Length	Order No.	Thread angle	Length	Order No.	Thread angle
25mm	167-261	60°	1"	167-294	60°
	167-272	55°		167-283	55°
50mm	167-262	60°	2"	167-295	60°
	167-273	55°		167-284	55°
75mm	167-263	60°	3"	167-296	60°
	167-274	55°		167-285	55°
100mm	167-264	60°	4"	167-297	60°
	167-275	55°		167-286	55°

Standards for V-Anvil Micrometers

SERIES 167



FEATURES

- Specially designed for the zero point setting of V-anvil micrometers.

SPECIFICATIONS

Metric			Inch		
Length	Order No.	Type	Length	Order No.	Type
5mm	167-327	Plug	.2"	167-337	Plug
10mm	167-328	Plug	.4"	167-338	Plug
25mm	167-329	Plug	1"	167-339	Plug
40mm	167-330	Plug	1.6"	167-340	Ring
55mm	167-331	Plug	2.2"	167-341	Ring
70mm	167-332	Plug	2.8"	167-342	Ring
85mm	167-333	Plug	3.4"	167-343	Ring

3-Wire Units

SERIES 313

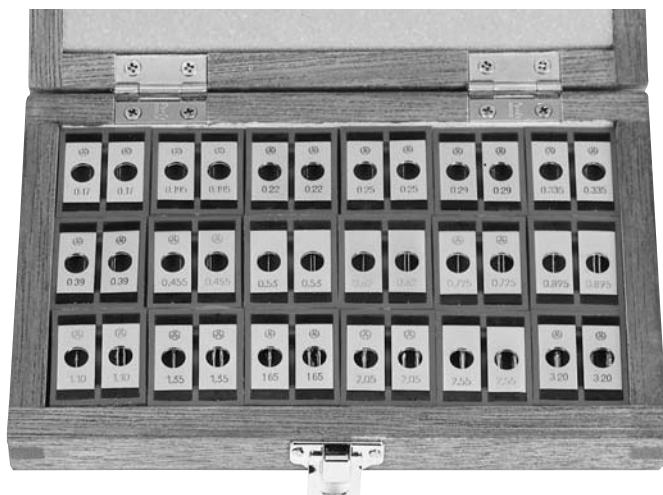

313-101

FEATURES

- Facilitates measurement of the pitch diameter of screw threads with a standard micrometer.
- 18 sizes of wires are assorted in a set.
- Roundness of wire: within 0.5µm
- Cylindricity of wire: within 1µm
- Hardness of wire: 59 - 63HRC

SPECIFICATIONS

Application	Order No.	Assortment of wire units
ø6.35mm (.25" DIA.)	313-101	0.17mm (952131), 0.195mm (952132), 0.22mm (952133), 0.25mm (952134), 0.29mm (952135), 0.335mm (952136), 0.39mm (952137), 0.455mm (952138), 0.53mm (952139), 0.62mm (952140), 0.725mm (952141), 0.895mm (952142), 1.1mm (952143), 1.35mm (952144), 1.65mm (952145), 2.05mm (952146), 2.55mm (952147), 3.2mm (952148)
ø8mm (.315" DIA.)	313-102	0.17mm (952149), 0.195mm (952150), 0.22mm (952151), 0.25mm (952152), 0.29mm (952153), 0.335mm (952154), 0.39mm (952155), 0.455mm (952156), 0.53mm (952157), 0.62mm (952158), 0.725mm (952159), 0.895mm (952160), 1.1mm (952161), 1.35mm (952162), 1.65mm (952163), 2.05mm (952164), 2.55mm (952165), 3.2mm (952166)

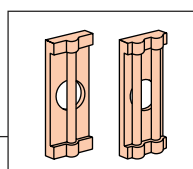

TECHNICAL INFORMATION

3-wire method

Formula to obtain the pitch diameter (E)*:
 $E = M - 3d + 0.866025P$

where P=Screw thread pitch
 d=Diameter of wire
 E=Pitch diameter
 M=Measured length
 *For metric or UNF screw

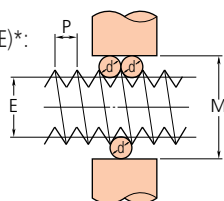

Micrometer Stands

SERIES 156

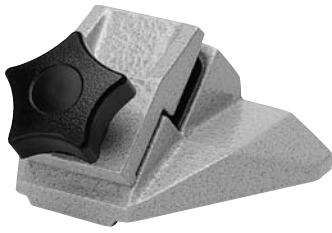

156-105

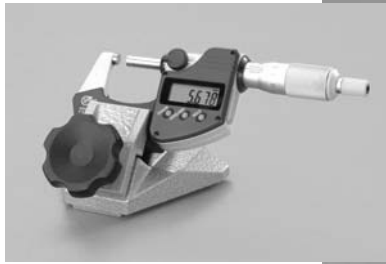

156-101



156-102



These stands are designed to allow bench-top use with hand micrometers or other gages which have frame area sufficient to grab onto.

SPECIFICATIONS

Micrometer ranges	Order No.	Remarks
0-25mm (0-1"), 25-50mm (1"-2")	156-105	Fixed angle type
Up to 100mm (4")	156-101	Adjustable angle type
Up to 300mm (12")	156-102	Vertical type
Over 300mm (12")	156-103	Vertical type

Dimensions

Unit: mm

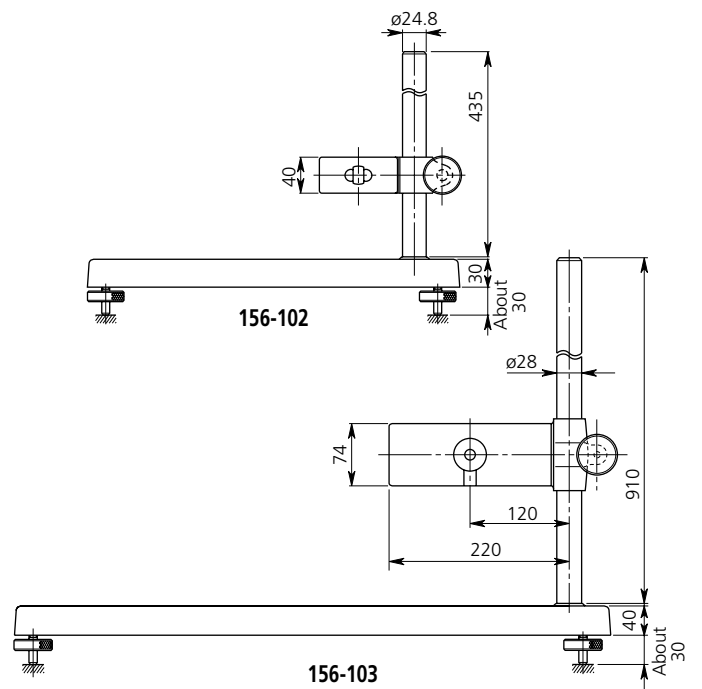
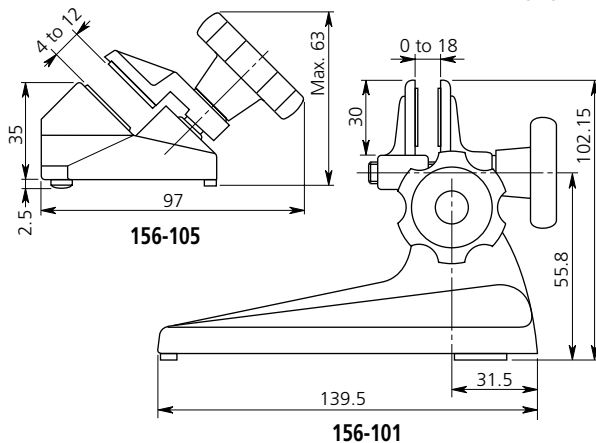

Groove Micrometers

SERIES 146

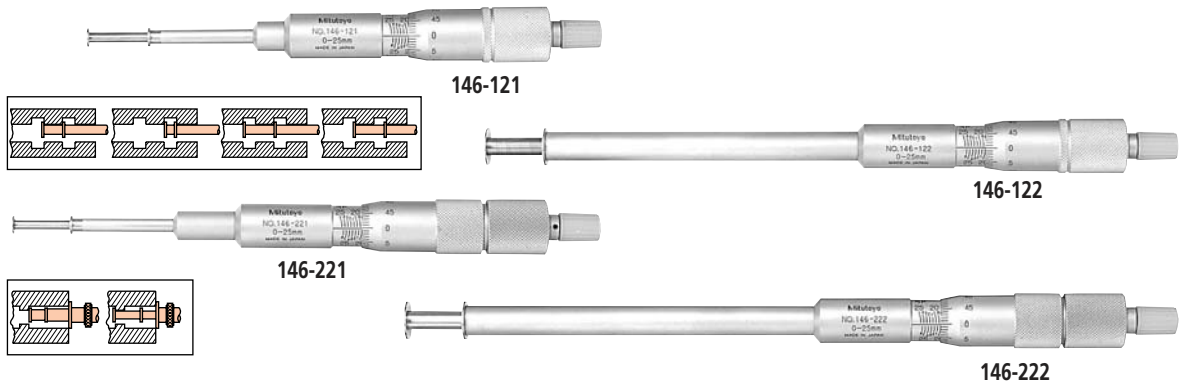

FEATURES

- Flanged spindle for measuring width, depth, and location of grooves inside/outside bores, and tubes.
- Provided with two types of graduations for inside and outside measurements.
- Non-rotating spindle type has two-directional ratchet stop (Measuring force: 5-10N).



SPECIFICATIONS

Metric		Rotating spindle type		
Range Outside	Range Inside	Order No.	Graduation	Flange diameter
0 - 25mm	1.6 - 26.5mm	146-121	0.01mm	6.35mm
		146-122	0.01mm	12.7mm
25 - 50mm	26.5 - 51.5mm	146-123	0.01mm	12.7mm
50 - 75mm	51.5 - 76.5mm	146-124	0.01mm	12.7mm
75 - 100mm	76.5 - 101.5mm	146-125	0.01mm	12.7mm

Metric		Non-rotating spindle type		
Range Outside	Range Inside	Order No.	Graduation	Flange diameter
0 - 25mm	1.6 - 26.5mm	146-221	0.01mm	6.35mm
		146-222	0.01mm	12.7mm
25 - 50mm	26.5 - 51.5mm	146-223	0.01mm	12.7mm
50 - 75mm	51.5 - 76.5mm	146-224	0.01mm	12.7mm
75 - 100mm	76.5 - 101.5mm	146-225	0.01mm	12.7mm

Inch		Rotating spindle type		
Range Outside	Range Inside	Order No.	Graduation	Flange diameter
0 - 1"	.055" - 1.05"	146-131	.001"	.25"
		146-132	.001"	.5"
1" - 2"	1.05" - 2.05"	146-133	.001"	.5"
2" - 3"	2.05" - 3.05"	146-134	.001"	.5"
3" - 4"	3.05" - 4.05"	146-135	.001"	.5"

Inch		Non-rotating spindle type		
Range Outside	Range Inside	Order No.	Graduation	Flange diameter
0 - 1"	.055" - 1.05"	146-231	.001"	.25"
		146-232	.001"	.5"
1" - 2"	1.05" - 2.05"	146-233	.001"	.5"
2" - 3"	2.05" - 3.05"	146-234	.001"	.5"
3" - 4"	3.05" - 4.05"	146-235	.001"	.5"

Accuracy

- Accuracy: $\pm 10\mu\text{m}$ ($\pm .0004"$)
- Parallelism: $10\mu\text{m}$ (.0004")

Dimensions

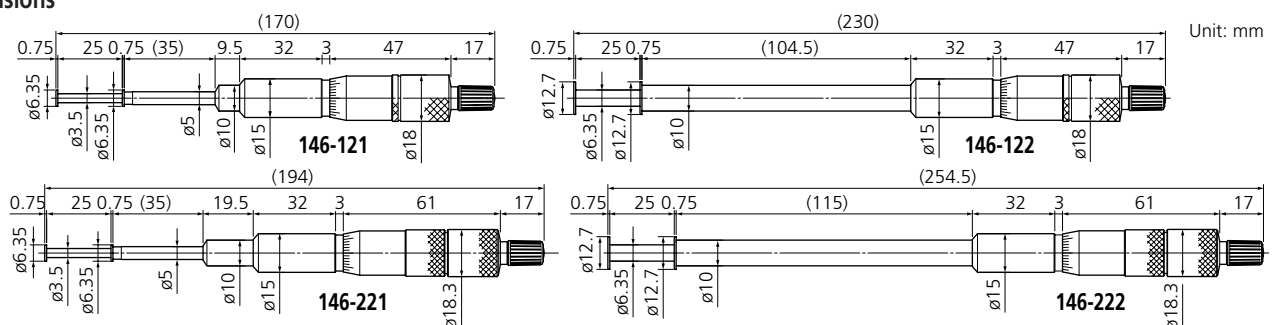

Depth Micrometers

SERIES 329, 229, 129 — Interchangeable Rod Type

MICROMETERS

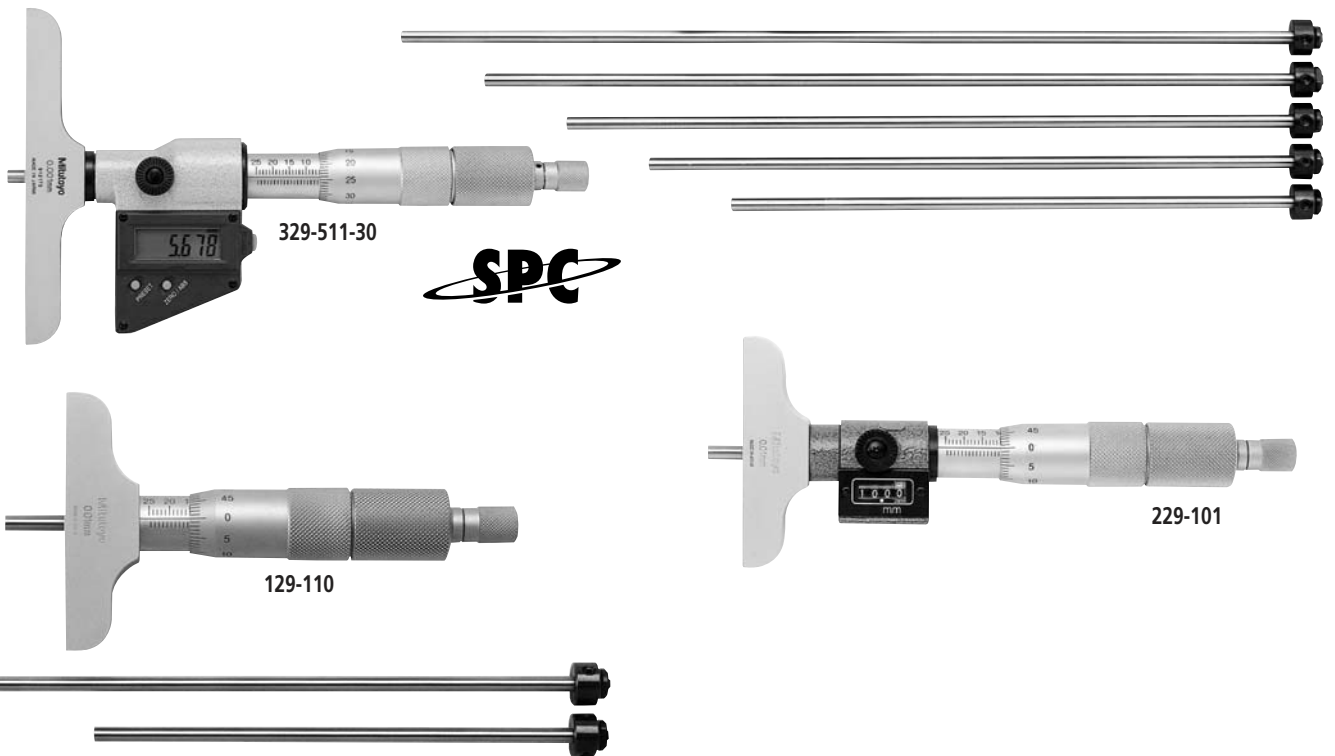

FEATURES

- $\varnothing 4\text{mm}$ (.157" DIA.) interchangeable rods, with lapped measuring end, provide a wide measuring range.
- The rod length can be adjusted in 25mm (1") increments.
- With Ratchet Stop for consistent force.
- Crisp clear graduations on the thimble.
- The 329 series (LCD readout type) are provided with SPC output.
- The 229 series are provided with a mechanical digit counter for quick and error-free reading.
- Complete with fitted carrying case.

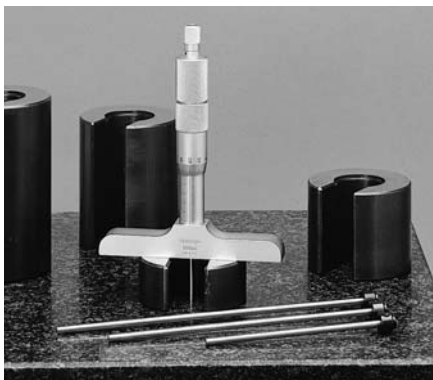

OPTIONAL ACCESSORIES

Order No.	Description
937387	SPC cable (1m)
965013	SPC cable (2m)

SPECIFICATIONS

Accuracy

- Accuracy of micrometer head: $\pm 3\mu\text{m}$ (.00015")
Excluding quantizing error. (329 series)
- Flatness of reference face:
1.3 μm (.00005") for base with 63.5mm (2.5") width
2 μm (.00008") for base with 101.6mm (4") width
- Flatness of measuring face of rod: 0.3 μm (.000012")
- Parallelism between reference face and measuring face:
 $(4+L/50)\mu\text{m}$ [($.00016+.00004(L/2)$)]*
* L=Maximum measuring length (mm) [(inch)], Fraction rounded up
- Accuracy of interchangeable rod:
 $\pm(2+L/75)\mu\text{m}$ [$\pm(.0001+.00005(L/3))$]*
* L=Maximum measuring length (mm) [(inch)], Fraction rounded up

Dimensions

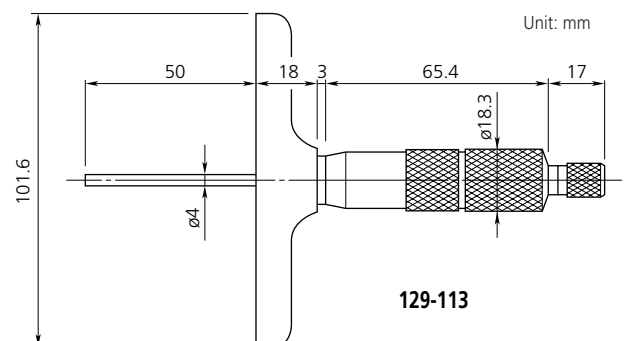



Metric		Digital model		
Range	Order No.	Resolution	Dimensions of reference face	Remarks
0 - 150mm	329-511-30	0.001mm	101.6X16mm	with 6 rods
0 - 300mm	329-512-30	0.001mm	101.6X16mm	with 12 rods

Inch/Metric		Digital model		
Range	Order No.	Resolution	Dimensions of reference face	Remarks
0 - 6"	329-711-30	.00005" / 0.001mm	4"X.63"	with 6 rods
0 - 12"	329-712-30	.0001" / 0.001mm	4"X.63"	with 12 rods

Metric		Mechanical counter model		
Range	Order No.	Graduation	Dimensions of reference face	Remarks
0 - 25mm	229-101	0.01mm	63.5X16mm	with 1 rod
	229-102	0.01mm	101.6X16mm	with 1 rod
0 - 50mm	229-109	0.01mm	63.5X16mm	with 2 rods
	229-113	0.01mm	101.6X16mm	with 2 rods

Inch		Mechanical counter model		
Range	Order No.	Graduation	Dimensions of reference face	Remarks
0 - 4"	229-127	.001"	2.5"X.63"	with 4 rods
	229-131	.001"	4"X.63"	with 4 rods
0 - 6"	229-128	.001"	2.5"X.63"	with 6 rods
	229-132	.001"	4"X.63"	with 6 rods

Metric				
Range	Order No.	Graduation	Dimensions of reference face	Remarks
0 - 50mm	129-109	0.01mm	63.5X16mm	with 2 rods
	129-113	0.01mm	101.6X16mm	with 2 rods
0 - 75mm	129-110	0.01mm	63.5X16mm	with 3 rods
	129-114	0.01mm	101.6X16mm	with 3 rods
0 - 100mm	129-111	0.01mm	63.5X16mm	with 4 rods
	129-115	0.01mm	101.6X16mm	with 4 rods
0 - 150mm	129-112	0.01mm	63.5X16mm	with 6 rods
	129-116	0.01mm	101.6X16mm	with 6 rods

Inch				
Range	Order No.	Graduation	Dimensions of reference face	Remarks
0 - 3"	129-126	.001"	2.5"X.63"	with 3 rods
	129-130	.001"	4"X.63"	with 3 rods
0 - 4"	129-127	.001"	2.5"X.63"	with 4 rods
	129-131	.001"	4"X.63"	with 4 rods
0 - 6"	129-128	.001"	2.5"X.63"	with 6 rods
	129-132	.001"	4"X.63"	with 6 rods
0 - 12"	129-149	.001"	2.5"X.63"	with 12 rods
	129-150	.001"	4"X.63"	with 12 rods

Depth Micrometers

SERIES 128

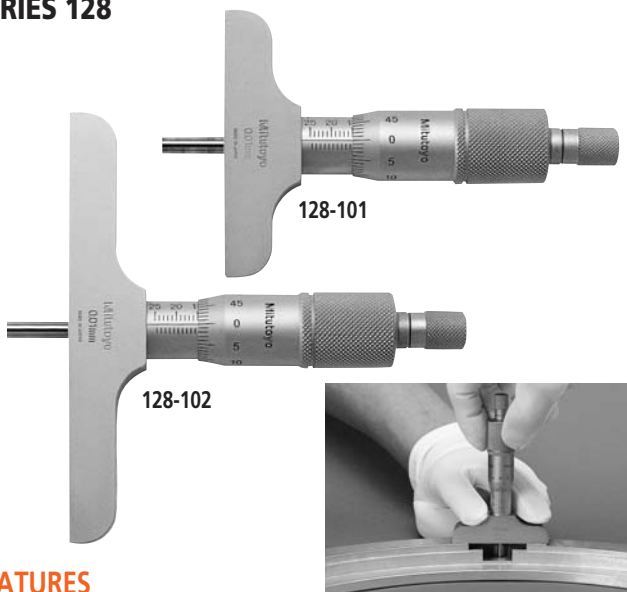

FEATURES

- Ratchet Stop for consistent and repetitive measurements.
- $\varnothing 4\text{mm}$ (.157" DIA.) measuring face.
- Satin-chrome finished throughout.
- With spindle locking clamp.
- Crisp clear graduations on the thimble.

SPECIFICATIONS

Metric			
Range	Order No.	Graduation	Dimensions of reference
0 - 25mm	128-101	0.01mm	63.5 x 16mm
	128-103*	0.01mm	63.5 x 16mm
	128-102	0.01mm	101.6 x 16mm
	128-104*	0.01mm	101.6 x 16mm

*The measuring face has a carbide tip.

Inch			
Range	Order No.	Graduation	Dimensions of reference
0 - 1"	128-105	.001"	2.5" x .63"
	128-106	.001"	4" x .63"

*The measuring face has a carbide tip.

Accuracy

- Accuracy of micrometer head: $\pm 3\mu\text{m}$ (.00015")
- Flatness of reference face:
 - 1.3 μm (.00005") for base with 63.5mm (2.5") width
 - 2 μm (.00008") for base with 101.6mm (4") width