

FEATURES

- High contact capacity with superior inrush current characteristics;

| | 1 Form A | 2 Form A |
|-----------|---------------|---------------|
| Rating | 30 A 277 V AC | 25 A 277 V AC |
| TV rating | TV-15 | TV-10 |

- Excellent high heat-resistance;
- High dielectric strength: 10,000 V surge Conforming to VDE0806 (Insulation gap: 8 mm .315 inch) VDE, TÜV also approved

SPECIFICATIONS

Contacts

| Type | DC coil type | | AC coil type | | |
|--|---------------------------------------|--|---------------|-------------------|---------------|
| Arrangement | 1a | 2a | 1a | 2a | |
| Contact material | AgSnO ₂ type | | | | |
| Initial contact resistance, max. (By voltage drop 6 V DC 1A) | 100 mΩ | | | | |
| Rating (resistive) | Nominal switching capacity | 30 A 277 V AC | 25 A 277 V AC | 30 A 277 V AC | 25 A 277 V AC |
| | Max. switching power | 8,310 VA | 6,925 VA | 8,310 VA | 6,925 VA |
| | Max. switching voltage | 277 V AC, 30 V DC | | | |
| | Max. switching current | 30 A | 25 A | 30 A | 25 A |
| | Min. switching capacity ^{#1} | 100 mA, 5 V DC | | | |
| Expected life (min. operations) | Mechanical (at 180 cpm) | 10 ⁷ | | 5×10 ⁶ | |
| | Electrical (at 20 cpm) | 10 ⁵ (1a: 30 A 277 V AC, 2a: 25 A 277 V AC) 2×10 ⁵ (1a: 30 A 250 V AC, 2a: 20 A 250 V AC) | | | |

Coil (at 20°C 68°F)

| | DC coil type | AC coil type |
|-------------------------|--------------|---------------------------|
| Nominal operating power | 1.92 W | See Coil data (next page) |

#1 This value can change due to the switching frequency, environmental conditions, and desired reliability level, therefore it is recommended to check this with the actual load.

Remarks

- * Specifications will vary with foreign standards certification ratings.
- *¹ Measurement at same location as "initial breakdown voltage" section
- *² Detection current: 10 mA
- *³ Wave is standard shock voltage of ±1.2×50μs according to JEC-212-1981
- *⁴ Excluding contact bounce time
- *⁵ Half-wave pulse of sine wave: 11ms; detection time: 10μs
- *⁶ Half-wave pulse of sine wave: 6ms
- *⁷ Detection time: 10μs
- *⁸ Refer to 6. Conditions for operation, transport and storage mentioned in [AMBIENT ENVIRONMENT](#) (p. 19, [Relay Technical Information](#)).

Characteristics

| | DC coil type | AC coil type |
|--|-------------------------------------|---|
| Maximum operating speed | 20 cpm | |
| Initial insulation resistance* ¹ | Min. 1,000 MΩ at 500 V DC | |
| Initial breakdown voltage* ² | Between open contacts | 2,000 Vrms for 1 min. |
| | Between contacts and coil | 5,000 Vrms for 1 min. |
| | Between contact sets (2a) | 4,000 Vrms for 1 min. |
| Surge voltage between coil and contact* ³ | Min. 10,000 V | |
| Operate time* ⁴ (at nominal voltage) | Max. 30 ms | |
| Release time* ⁴ (at nominal voltage) | Max. 10 ms | Max. 30 ms |
| Temperature rise, max. (resistive load)(at 55°C) | 60°C | 65°C |
| Shock resistance | Functional* ⁵ | 98 m/s ² {10 G} |
| | Destructive* ⁶ | 980 m/s ² {100 G} |
| Vibration resistance | Functional* ⁷ | 10 to 55 Hz at double amplitude of 1 mm |
| | Destructive | 10 to 55 Hz at double amplitude of 1.5 mm |
| Conditions for operation, transport and storage* ⁸ (Not freezing and condensing at low temperature) | Ambient temp. | -50°C to +55°C -58°F to +131°F |
| | Humidity | 5 to 85% R.H. |
| | Air pressure | 86 to 106 kPa |
| Unit weight | Approx. 90 g 3.17 oz (Plug-in type) | |

TYPICAL APPLICATIONS

- Home appliances
 - Air conditioners
 - Microwave ovens
 - TV sets
 - Heaters
 - Stereo
- Office equipment
 - Copiers
 - Vending machines

ORDERING INFORMATION

| Contact arrangement | Pick-up voltage | Terminals | Coil voltage |
|------------------------------|---------------------------|---|--|
| 1a: 1 Form A 2a: 2 Form A | N: 70% of nominal voltage | Nil: Plug-in terminal type S: Screw terminal type SW: Screw terminal type (wide pitch) Q: NEMA terminal type P: PC board terminal type* | DC: 6, 12, 24, 48, 110 V AC: 12, 24, 48, 120, 240 V |

Standard packing: Carton: 20 pcs.; Case: 100 pcs.
* PC board terminal are available only for 1 Form A type of DC coil voltage.
UL/CSA, TÜV approved type is standard.

TYPES

| | Terminal shape | Contact arrangement | |
|-------------------|-----------------------------|---------------------|-----------------|
| | | 1 Form A | 2 Form A |
| DC type | Plug-in terminal | HE1aN-DC6V | HE2aN-DC6V |
| | | HE1aN-DC12V | HE2aN-DC12V |
| | | HE1aN-DC24V | HE2aN-DC24V |
| | | HE1aN-DC48V | HE2aN-DC48V |
| | | HE1aN-DC110V | HE2aN-DC110V |
| | Screw terminal | HE1aN-S-DC6V | HE2aN-S-DC6V |
| | | HE1aN-S-DC12V | HE2aN-S-DC12V |
| | | HE1aN-S-DC24V | HE2aN-S-DC24V |
| | | HE1aN-S-DC48V | HE2aN-S-DC48V |
| | | HE1aN-S-DC110V | HE2aN-S-DC110V |
| | Screw terminal (wide pitch) | HE1aN-SW-DC6V | HE2aN-SW-DC6V |
| | | HE1aN-SW-DC12V | HE2aN-SW-DC12V |
| | | HE1aN-SW-DC24V | HE2aN-SW-DC24V |
| | | HE1aN-SW-DC48V | HE2aN-SW-DC48V |
| | | HE1aN-SW-DC110V | HE2aN-SW-DC110V |
| | NEMA terminal | HE1aN-Q-DC6V | HE2aN-Q-DC6V |
| | | HE1aN-Q-DC12V | HE2aN-Q-DC12V |
| | | HE1aN-Q-DC24V | HE2aN-Q-DC24V |
| | | HE1aN-Q-DC48V | HE2aN-Q-DC48V |
| | | HE1aN-Q-DC110V | HE2aN-Q-DC110V |
| PC board terminal | HE1aN-P-DC6V | — | |
| | HE1aN-P-DC12V | — | |
| | HE1aN-P-DC24V | — | |
| | HE1aN-P-DC48V | — | |
| | HE1aN-P-DC110V | — | |

| | Terminal shape | Contact arrangement | |
|----------------|-----------------------------|---------------------|-----------------|
| | | 1 Form A | 2 Form A |
| AC type | Plug-in terminal | HE1aN-AC12V | HE2aN-AC12V |
| | | HE1aN-AC24V | HE2aN-AC24V |
| | | HE1aN-AC48V | HE2aN-AC48V |
| | | HE1aN-AC120V | HE2aN-AC120V |
| | | HE1aN-AC240V | HE2aN-AC240V |
| | | HE1aN-S-AC12V | HE2aN-S-AC12V |
| | Screw terminal | HE1aN-S-AC12V | HE2aN-S-AC12V |
| | | HE1aN-S-AC24V | HE2aN-S-AC24V |
| | | HE1aN-S-AC48V | HE2aN-S-AC48V |
| | | HE1aN-S-AC120V | HE2aN-S-AC120V |
| | | HE1aN-S-AC240V | HE2aN-S-AC240V |
| | Screw terminal (wide pitch) | HE1aN-SW-AC12V | HE2aN-SW-AC12V |
| | | HE1aN-SW-AC24V | HE2aN-SW-AC24V |
| | | HE1aN-SW-AC48V | HE2aN-SW-AC48V |
| | | HE1aN-SW-AC120V | HE2aN-SW-AC120V |
| | | HE1aN-SW-AC240V | HE2aN-SW-AC240V |
| | | HE1aN-Q-AC12V | HE2aN-Q-AC12V |
| | NEMA terminal | HE1aN-Q-AC12V | HE2aN-Q-AC12V |
| | | HE1aN-Q-AC24V | HE2aN-Q-AC24V |
| | | HE1aN-Q-AC48V | HE2aN-Q-AC48V |
| HE1aN-Q-AC120V | | HE2aN-Q-AC120V | |
| HE1aN-Q-AC240V | | HE2aN-Q-AC240V | |

COIL DATA at 20°C 68°F

| | Nominal voltage | Pick-up voltage, V DC (max.) | Drop-out voltage, V DC (min.) | Nominal coil current, mA (±10%) | Coil resistance, Ω (±10%) | Nominal operating power, W | Max. allowable voltage (at 50°C 122°F), V DC |
|--------------|-----------------|------------------------------|-------------------------------|---------------------------------|---------------------------|----------------------------|--|
| DC coil type | 6 V DC | 4.2 | 0.6 | 320.9 | 18.8 | 1.92 | 6.6 |
| | 12 V DC | 8.4 | 1.2 | 160 | 75 | 1.92 | 13.2 |
| | 24 V DC | 16.8 | 2.4 | 80 | 300 | 1.92 | 26.4 |
| | 48 V DC | 33.6 | 4.8 | 40 | 1200 | 1.92 | 52.8 |
| | 110 V DC | 77.0 | 11.0 | 17.5 | 6300 | 1.92 | 121.0 |

| | Nominal voltage | Pick-up voltage, V AC (max.) | Drop-out voltage, V AC (min.) | Nominal coil current, mA (±10%) | Coil resistance, Ω (±10%) | Nominal operating power, VA | Max. allowable voltage (at 50°C 122°F), V AC |
|--------------|-----------------|------------------------------|-------------------------------|---------------------------------|---------------------------|-----------------------------|--|
| AC coil type | 12 V AC | 8.4 | 1.8 | 138* | 75 | 1.7 | 13.2 |
| | 24 V AC | 16.8 | 3.6 | 74* | 300 | 1.8 | 26.4 |
| | 48 V AC | 33.6 | 7.2 | 39* | 1200 | 1.9 | 52.8 |
| | 120 V AC | 70.0 | 18.0 | 22.1* | 5200 | 2.7 | 132.0 |
| | 240 V AC | 140.0 | 36.0 | 10.8* | 20800 | 2.6 | 264.0 |

*Value at 60 Hz

DIMENSIONS

1. Plug-in terminal type

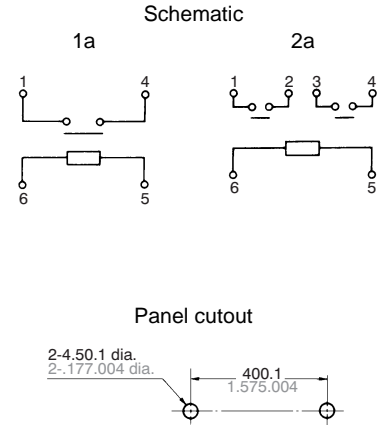
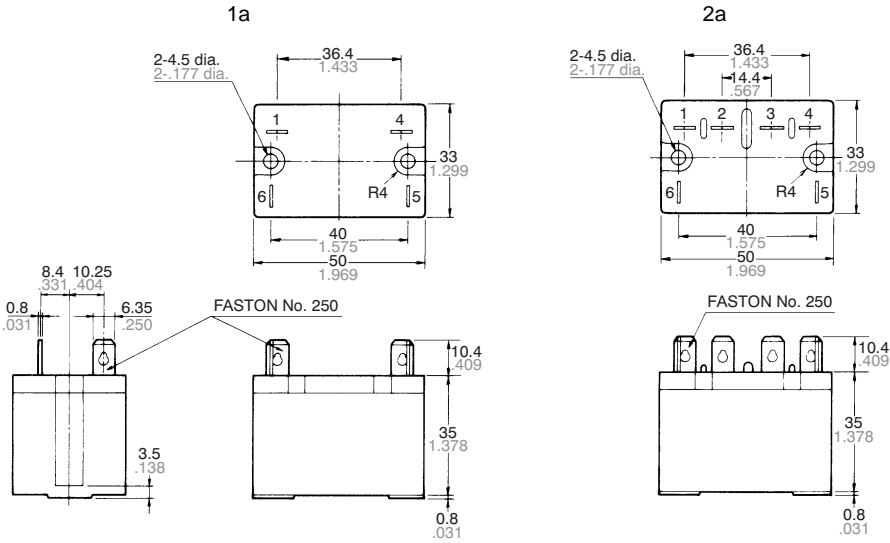

General tolerance: $\pm 0.3 \pm .012$

2. NEMA terminal type

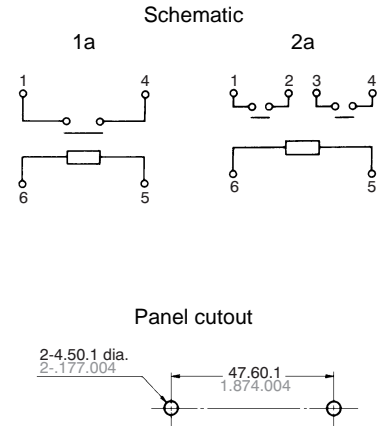
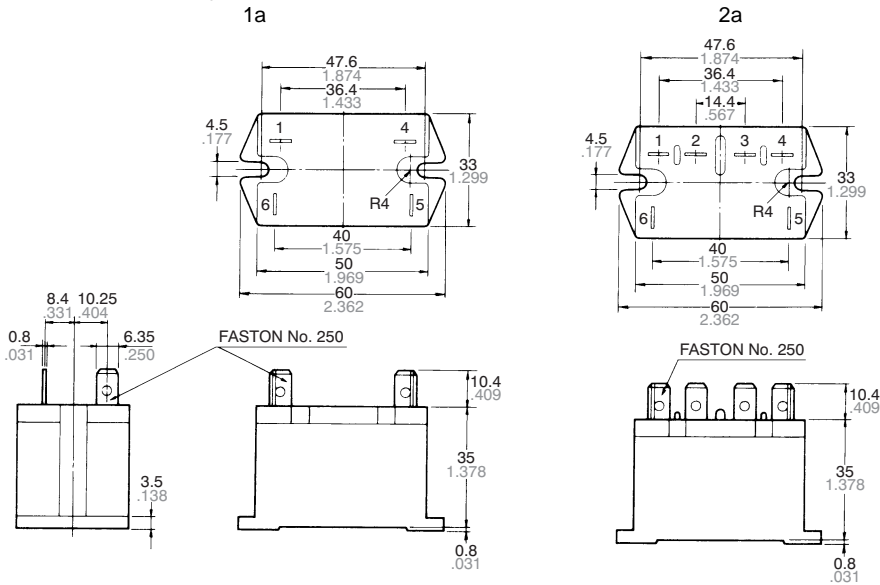

General tolerance: $\pm 0.3 \pm .012$

3. Screw terminal type

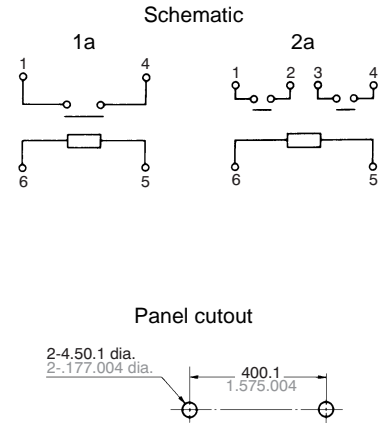
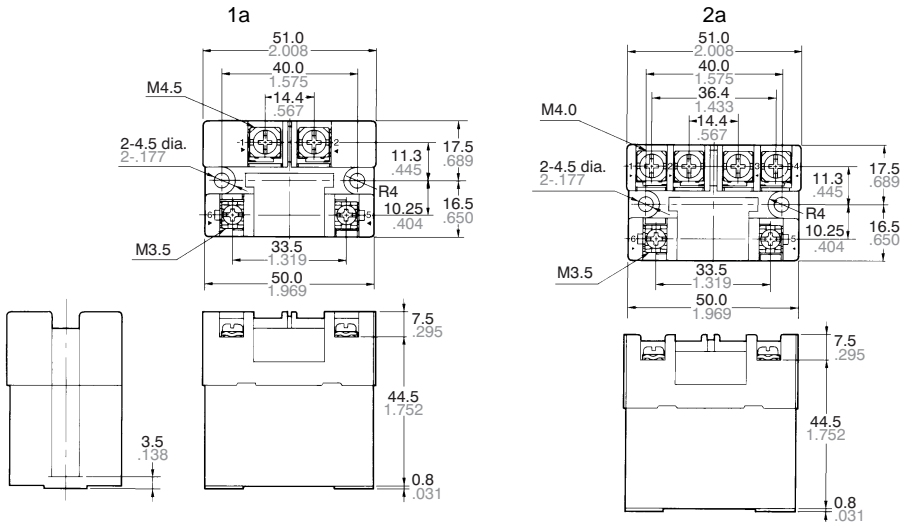

General tolerance: $\pm 0.3 \pm .012$

4. Screw terminal type (wide pitch)

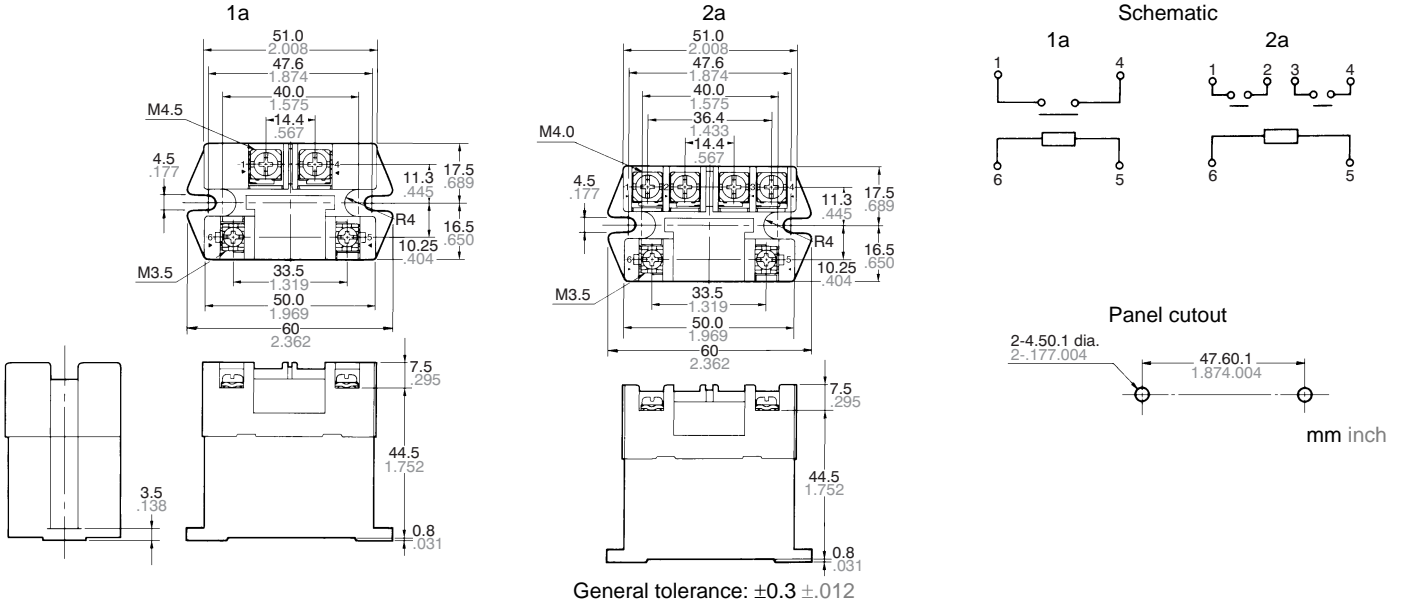

5. PC board terminal type

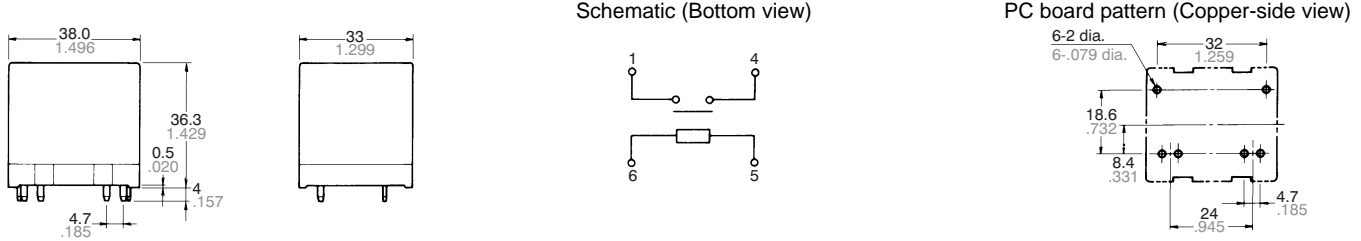

REFERENCE DATA

1 Form A Type

1. Maximum switching power

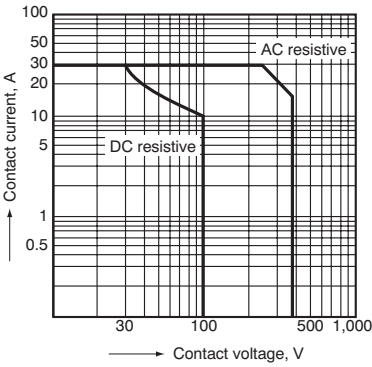

2. Life curve

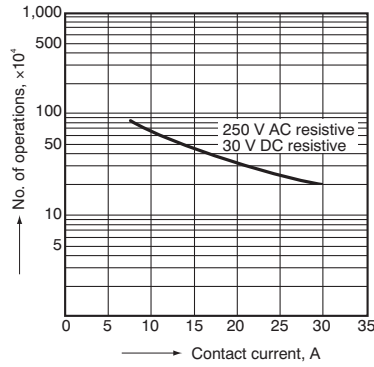

3. Contact temperature rise (DC type)

Measured portion: Inside the coil
Contact current: 30 A

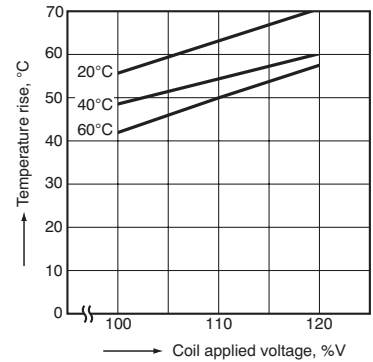

4. Ambient temperature characteristics

Sample: HE1aN-AC120V, 6 pcs.

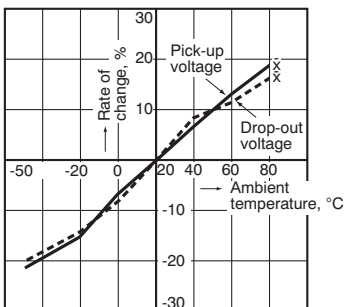

1 Form A Type

1. Maximum switching power

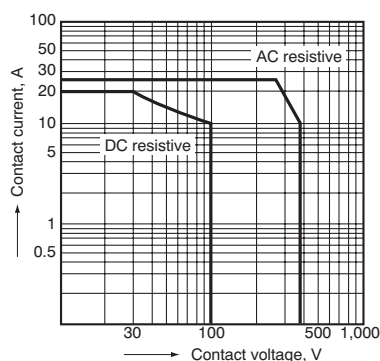

2. Life curve

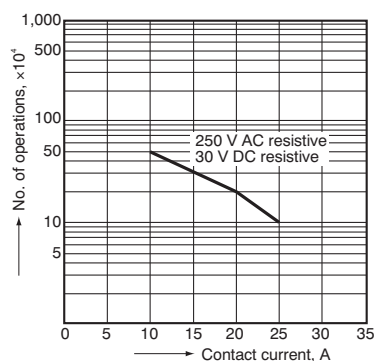

3. Contact temperature rise (DC type)

Measured portion: Inside the coil
Contact current: 30 A

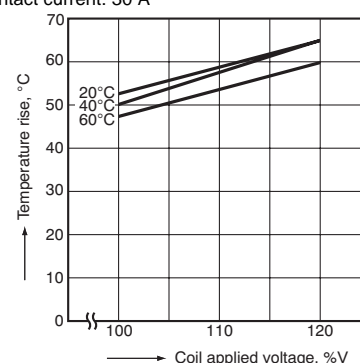

4. Ambient temperature characteristics

Sample: HE2aN-AC120V, 6 pcs.

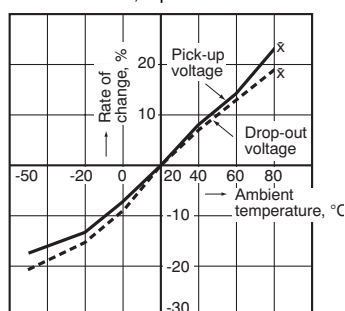

MOUNTING METHOD

1. Plug-in terminal type

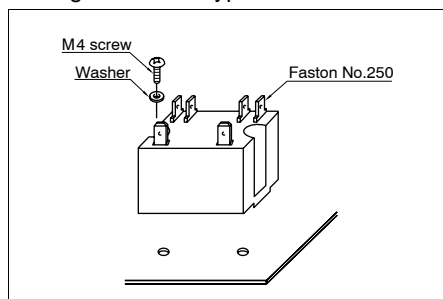

2. Screw terminal type

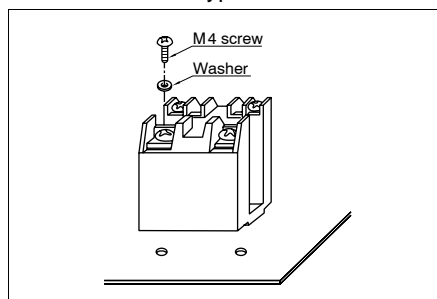

3. Allowable installation wiring size for screw terminal types and terminal blocks

| | |
|---------|-------------------------------|
| 1a type | 2.6 mm or 5.5 mm ² |
| 2a type | 2.0 mm or 3.5 mm ² |

Due to the UP terminals, it is possible to either directly connect the wires or use crimped terminal

NOTES

- The dust cover should not be removed since doing so may alter the characteristics.
- Avoid use under severe environmental conditions, such as high humidity, organic gas or in dust, oily locations and locations subjected to extremely frequent shock or vibrations.
- When mounting, use spring washers. Optimum fastening torque ranges from 5 kg to 7 kg-cm 4.5 to 6 pounds-inch.
- Firmly insert the receptacles so that there is no slack or looseness. To remove a receptacle, 2 to 4 kg of pulling strength

- is required. Do not remove more than one receptacle at one time. Always remove one receptacle at a time and pull it straight outwards.
- Install the relay so that it lies in direction A (up-down direction). (Pick-up voltage and drop-out voltage values are those when installed in direction A.)
- When using the AC type, the operate time due to the in-rush phase is 20 ms or more. Therefore, it is necessary for you to verify the characteristics for your actual circuit. Moreover, the release time for the NC side of the 2a1b type requires the

same verification.

- When using the push-on blocks for the screw terminal type, use crimped terminals and tighten the screw-down terminals to the torque's listed below.

| | |
|------------|--|
| M4.5 screw | 147 N-cm to 166.6 N-cm (15 to 17 kg-cm) |
| M4 screw | 117.6 N-cm to 137 N-cm (12 to 14 kg-cm) |
| M3.5 screw | 78.4 N-m to 98 N-cm (8 to 10 kg-cm) |

- All AC240V types are rated for double coil voltage, both AC 220V AC 240V.

For Cautions for Use, see [Relay Technical Information](#).

HE

HE RELAY ACCESSORIES

Terminal socket instantly attachable to DIN rail



TYPES

| Part No. | Applicable relays |
|----------|-------------------|
| JH1-SF | HE1a |
| JH2-SF | HE2a |

SPECIFICATIONS

| Part No. | JH1, JH2 |
|-----------------------------|-----------------------------------|
| Maximum continuous current* | 20 A 250 V AC (1a: 30 A 250 V AC) |
| Breakdown voltage | 2,000 Vrms between terminals |
| Insulation resistance | More than 1,000 MΩ between poles |
| Heat resistance | 150°C ±3°C for 1 hour |

* Don't insert or remove relays while in the energized condition.

DIMENSIONS

mm inch

1 Form A, 2 Form A

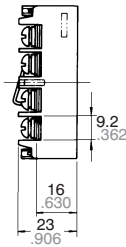
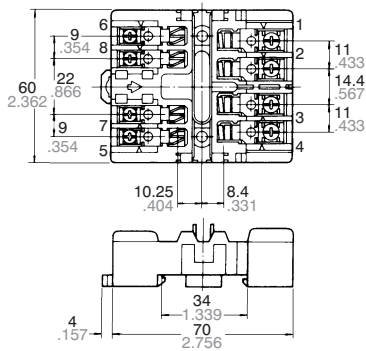

Relay mounting diagram

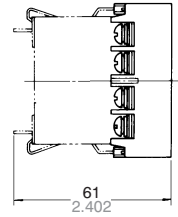

Panel cutout

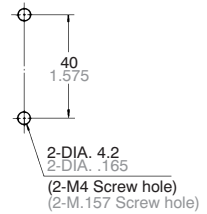

Note:

JH1-SF does not have receptacles (tooth rests) for numbers 2, 3, 7, and 8.
JH2-SF does not have receptacles (tooth rests) for numbers 7 and 8.

MOUNTING METHOD

1. Relay mounting

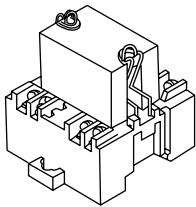

2. Installing to a DIN rail

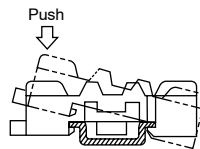

3. Removing from a DIN rail

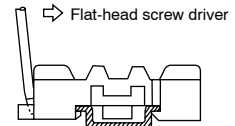

NOTE

1. Be careful not to drop the relay. It is made of heat-hardened resin and may break.

2. Be sure to tighten the screw-down terminals firmly. Loose terminals may lead to the generation of heat.