

HA12088ANT, HA12090NT, HA12091AMP

T-77-21

Dolby™ B-C Type Noise Reduction System

Description

The HA12088ANT/HA12090NT/HA12091AMP silicon monolithic bipolar integrated circuit provides dual channel Dolby B-C Type noise reduction within one package. ('Dolby' is a trademark of Dolby Laboratories Licensing Corporation).

The HA12088ANT/HA12090NT/HA12091AMP reduces the level of background noise produced during recording and playback of audio signals on magnetic tape.

The HA12088ANT/HA12090NT/HA12091AMP is available only to licensees of Dolby Laboratories Licensing Corporation. Licensing and application information may be obtained from Dolby Laboratories Licensing Corporation.

Functions

- Dual Dolby B-C Type NR processors
- Programmable line out level
- MPX filter drive circuit

Features

- Few external components required
- Two package types (DP-42SA, MP-44)
- Wide supply voltage range: 7.5 V to 16 V

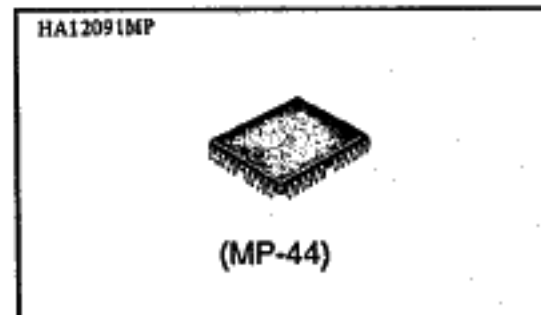

Pin Configuration

HA12088ANT	HA12090NT	DP-42SA	HA12088ANT	HA12090NT
REC IN (R)	←	1	Vcc	←
GND	←	2	REC IN (L)	REF (L)
PB IN (R)	OPEN FIX	3	40	BIAS I
REF	REF (R)	4	39	PB IN (L)
B/C OFF	←	5	38	B/P
LA OUT (R)	←	6	37	GND FIX
SLR IN (R)	←	7	27	LA OUT (L)
PB IN (R)	NOISE IN (R)	8	26	SLR IN (L)
PB OUT (R)	NOISE OUT (R)	9	25	OPEN FIX
SS IN (R)	←	10	24	PB IN (L)
SS OUT (R)	←	11	23	PB OUT (L)
HLS CCR (R)	←	12	22	SS IN (L)
HLS HPP (R)	←	13	21	SS OUT (L)
HLS Det1 (R)	←	14	20	HLS CCR (L)
HLS Det2 (R)	←	15	19	HLS HPP (L)
AS (R)	←	16	18	HLS Det1 (L)
LLS CCR (R)	←	17	17	HLS Det2 (L)
LLS HPP (R)	←	18	16	AS (L)
LLS Det1 (R)	←	19	15	LLS CCR (L)
LLS Det2 (R)	←	20	14	LLS HPP (L)
REC OUT (R)	←	21	13	LLS Det1 (L)
			12	LLS Det2 (L)
			11	REC OUT (L)
			10	
			9	
			8	
			7	
			6	
			5	
			4	
			3	
			2	
			1	



T-77-21

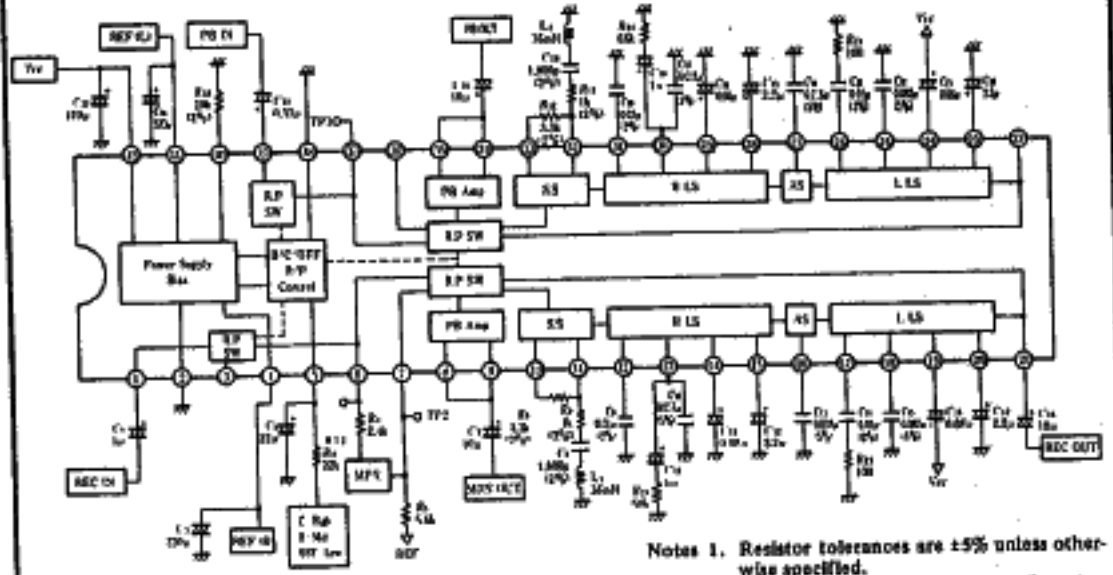

- Notes 1. Resistor tolerances are $\pm 5\%$ unless otherwise specified.
 2. Capacitor tolerances are $\pm 20\%$ unless otherwise specified.
 3. Unit R: Ω C: F
 4. 22k at 10V to 16V, 12k at 7.5V to 16V.

Figure 2 HA12090NT Block Diagram with External Components



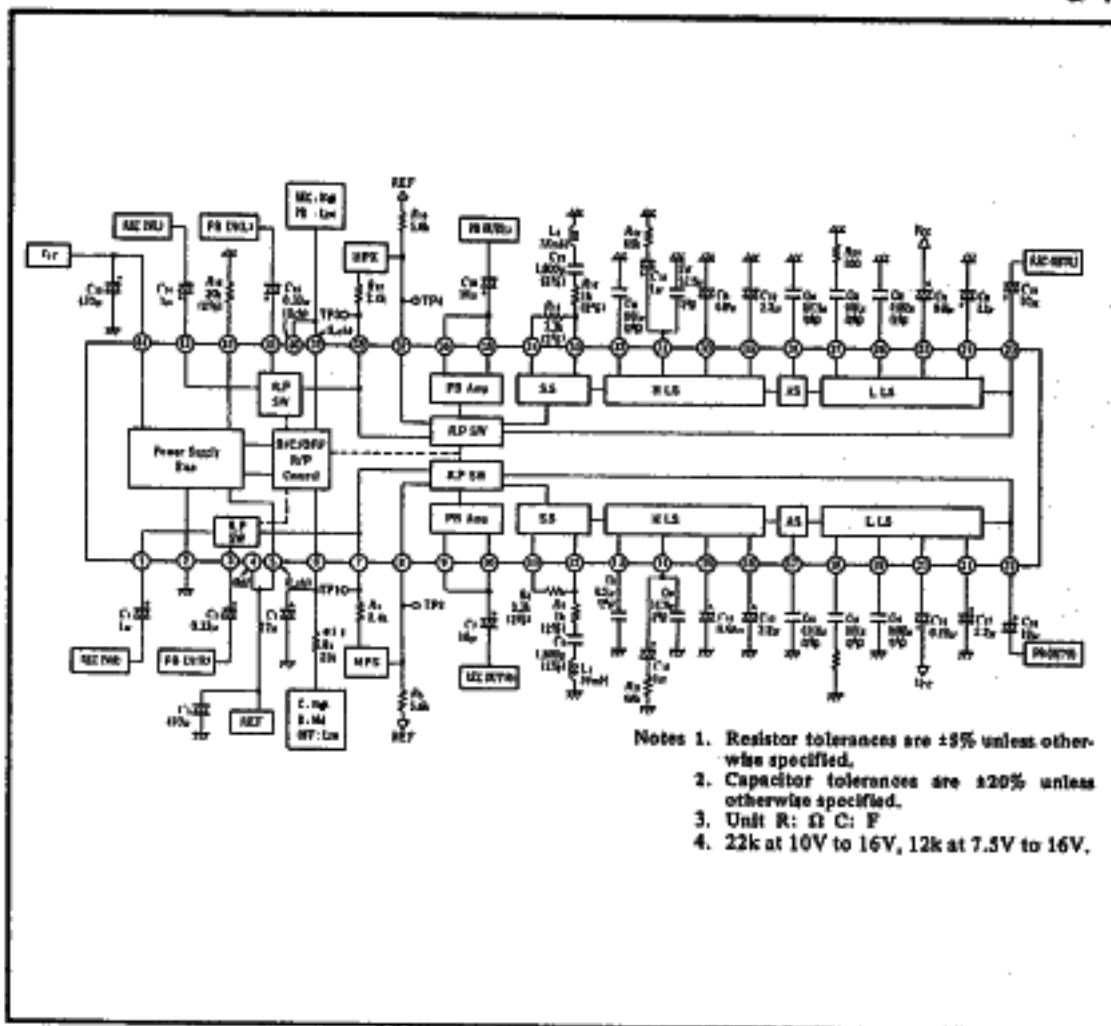

Figure 3 HA12091AMP Block Diagram with External Components



HA12088ANT/HA12090NT/HA12091AMP

Table 1 HA12088ANT/HA12090NT/HA12091AMP Functions

T-77-21

Functions	HA12088ANT	HA12090NT	HA12091AMP
Applications	For normal use	For 3 head-type use	For normal and 3 head-type use
Package	DP-42S	DP-42S	MP-44
Channels	2-ch	L-ch PB FIX R-ch Rec FIX	2-ch
Encode/decode switch	L-ch common R-ch	L-ch PB FIX R-ch Rec FIX	L-ch separate R-ch
Reference	L-ch common R-ch	L-ch separate R-ch	L-ch separate R-ch
B NR/C NR/NR off switch	L-ch common R-ch	L-ch common R-ch	L-ch common R-ch
Input (Rec/PB) switch	L-ch common R-ch	L-ch PB FIX R-ch Rec FIX	L-ch separate R-ch
MPX drive	Built-in	Built-in	Built-in
Programmable output (see note)	Built-in	Built-in	Built-in

Note: The circuit shown in the block diagram gives a reference output level of 300 mV. By using the circuit configurations shown in figure 4, it is possible to select a higher line of output levels.



HA12088ANT/HA12090NT/HA12091AMP

T-77-21

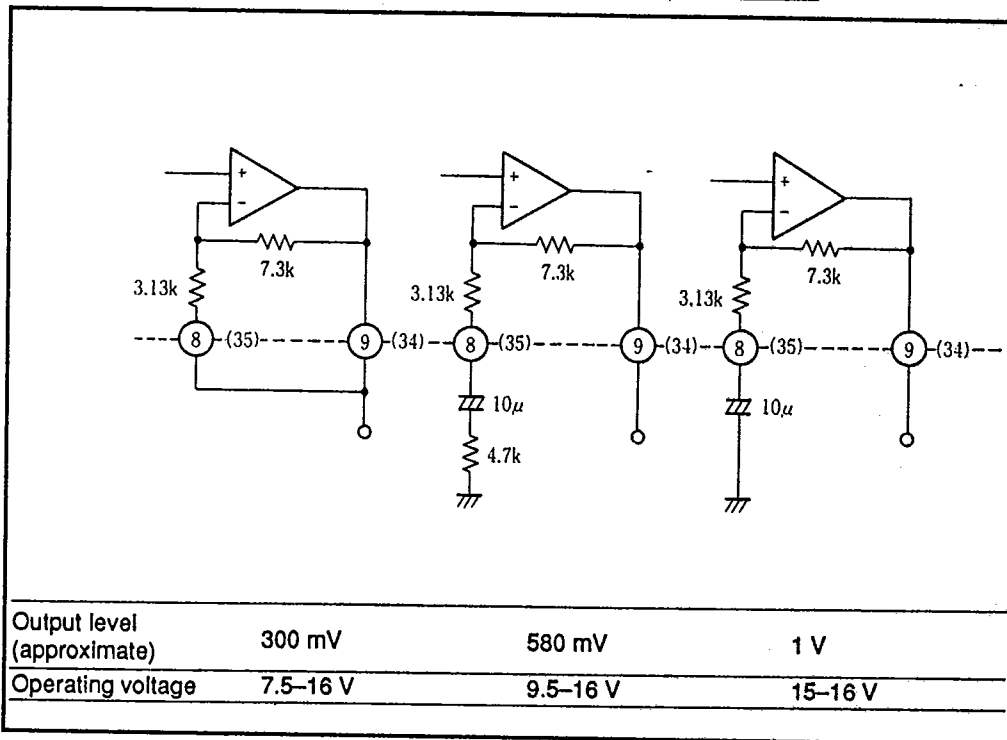

Figure 4 Circuit Configuration Diagrams



HA12088ANT/HA12090NT/HA12091AMP

Absolute Maximum Ratings (Ta = 25°C, unless otherwise specified)

T-77-21

Item	Symbol	Rating	Unit
Supply voltage	V _{CC(max)}	16	V
Lead temperature (10 s soldering)	T _l	260	°C
Power dissipation (DP-42S)	P _T	1111	mW
(Ta ≤ 70°C) (MP-44) (see note)		940	
Operating temperature	T _{opr}	-20 to +70	°C
Storage temperature	T _{stg}	-55 to +125	°C

Note: On a 40 mm square ceramic board

Electrical Characteristics Ta = 25°C, V_{CC} = 14 V, unless otherwise specified

Dolby level = 300 mV_{rms} at TP (Rec: TP2, TP4, PB: TP1, TP3)

Item	Symbol	Min	Typ	Max	Unit	Test Conditions			
						R/P	NR	f(Hz)	other
Operating voltage	V _{opr}	7.5	—	16	V	—	—	—	
Quiescent current	I _{CC}	—	22	—	mA	R	off	—	No signal
Input amp gain	G _v (IA Rec)	—	18.6	—	dB	R	off	1 k	
	G _v (IA PB)	—	20.0	—		P	off	1 k	
B-type encode boost	B-ENC-2K	2.8	4.3	5.8		R	B	2 k	V _{in} = -20 dB
	B-ENC-5K	1.7	3.2	4.7		R	B	5 k	V _{in} = -20 dB
C-type encode boost	C-ENC-1K(1)	3.9	5.9	7.9		R	C	1 k	V _{in} = -20 dB
	C-ENC-1K(2)	18.1	19.6	21.6		R	C	1 k	V _{in} = -60 dB
	C-ENC-700	9.8	11.8	13.8		R	C	700	V _{in} = -30 dB
B-type decode cut	B-DEC-2K	-5.8	-4.3	-2.8		P	B	2 k	V _{out} = -20 dB
	B-DEC-5K	-4.7	-3.2	-1.7		P	B	5 k	V _{out} = -20 dB
C-type decode cut	C-DEC-1K(1)	-7.9	-5.9	-3.9		P	C	1 k	V _{out} = -20 dB
	C-DEC-1K(2)	-21.6	-19.6	-18.1		P	C	1 k	V _{out} = -60 dB
Signal handling	V _{O(max)}	12	13	—		R	off	1 k	THD = 1%, V _{CC} = 7.5 V
Signal-to-noise ratio at encode (C-type)	S/N(ENC)	61	65	—		R	C	—	R _g = 10 kΩ, CCIR/ARM



HA12088ANT/HA12090NT/HA12091AMP

T-77-21

Electrical Characteristics (cont)

Item	Symbol	Min	Typ	Max	Unit	Test Conditions			
						R/P	NR	f(Hz)	other
Total harmonic distortion	THD (off)	—	0.03	0.15	%	R	off	1 k	$V_{in} = 0$ dB
	THD(C)	—	0.09	0.3		R	CF	1 k	$V_{in} = 0$ dB
NR off frequency response	Off-FR	—	-0.4	—	dB	R	off	20 k	$V_{in} = 0$ dB
Crosstalk between Rec-PB	CT(R ⇒ P)	—	72	—		P	off	1 k	$V_{in} = 0$ dB
	CT(P ⇒ R)	—	80	—		R	off	1 k	$V_{in} = 0$ dB
Crosstalk between channels	CT(L ⇔ R)	—	70	—		R	off	1 k	$V_{in} = 0$ dB
Control voltage for Rec-PB	$V_{cont}(Rec)$	6.7	—	7.3	V	—	—	—	—
	$V_{cont}(PB)$	0	—	1.0					
Control voltage for B-C and NR OFF	$V_{cont}(C)$	9.0	—	14					
	$V_{cont}(B)$	6.0	—	6.8					
	$V_{cont}(Off)$	0.5	—	4.0					
Ripple rejection ratio	R.R.R.	—	32	—	dB	R	C	100	—



HA12088ANT/HA12090NT/HA12091AMP

HA12088ANT Test Circuit

T-77-21

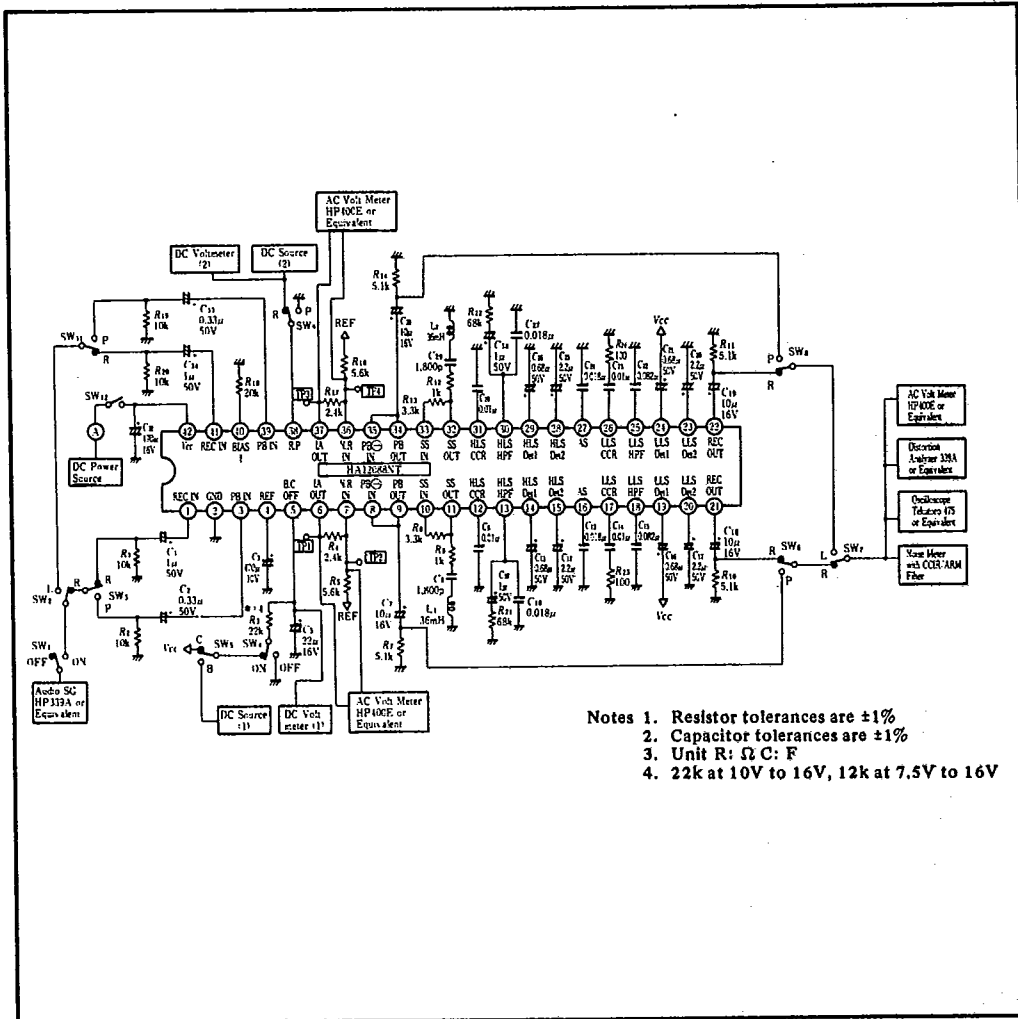

- Notes
1. Resistor tolerances are $\pm 1\%$
 2. Capacitor tolerances are $\pm 1\%$
 3. Unit R: Ω ; C: F
 4. 22k at 10V to 16V, 12k at 7.5V to 16V

Figure 5 HA12088ANT Test Circuit



Typical Performance Curves

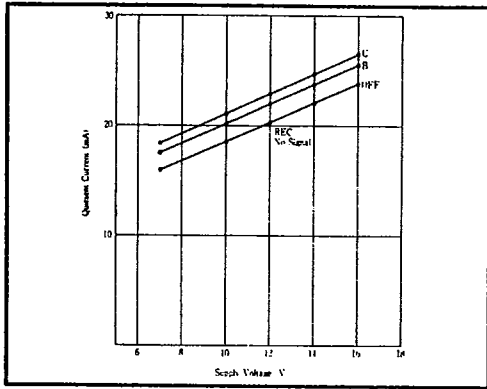

Figure 6 Quiescent Current vs Supply Voltage

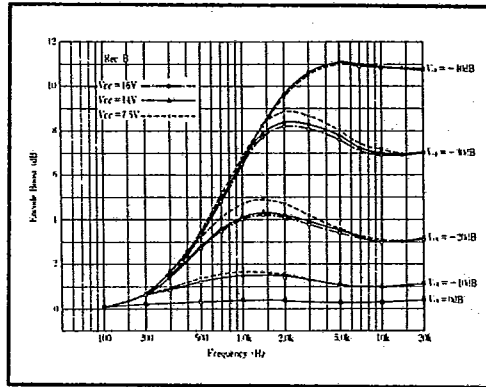

Figure 7 B-Type NR Encode Boost vs Frequency

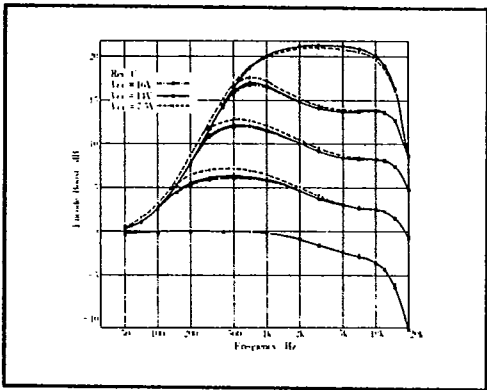

Figure 8 C-Type NR Encode Boost vs Frequency

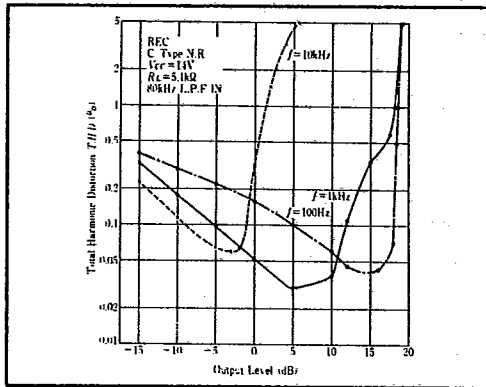

Figure 9 REC (Recording) C-Type NR Total Harmonic Distortion vs Output Level

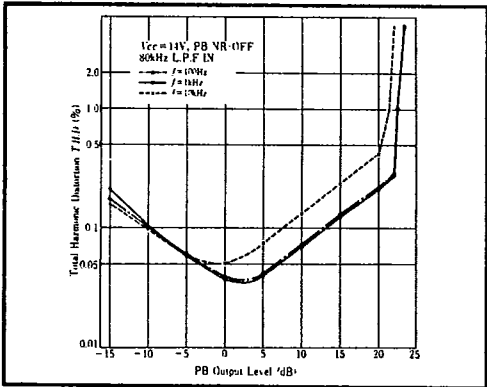

Figure 10 REC NR Off Total Harmonic Distortion vs Output Level

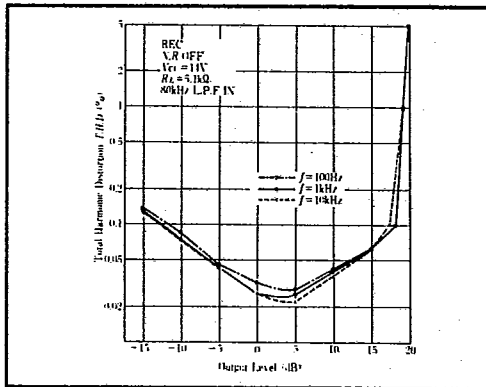

Figure 11 PB (Playback) NR Off Total Harmonic Distortion vs Output Level



HA12088ANT/HA12090NT/HA12091AMP

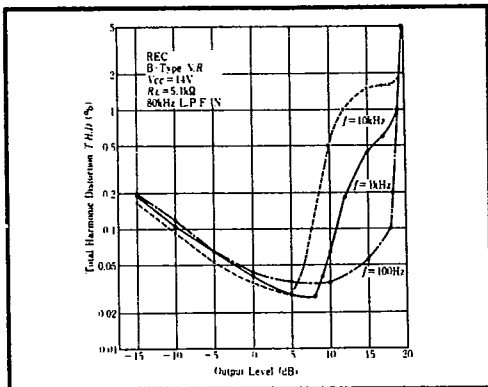

Figure 12 REC B-Type NR Total Harmonic Distortion vs Output Level

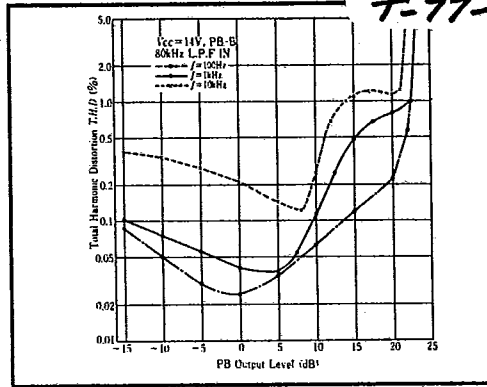

Figure 13 PB B-Type NR Total Harmonic Distortion vs Output Level

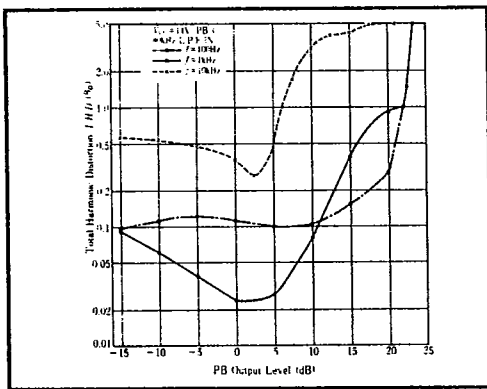

Figure 14 PB C-Type NR Total Harmonic Distortion vs Output Level

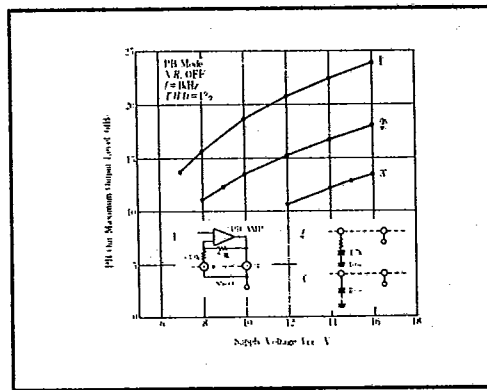

Figure 15 PB Out Maximum Output Level vs Supply Voltage for Variable Output Level

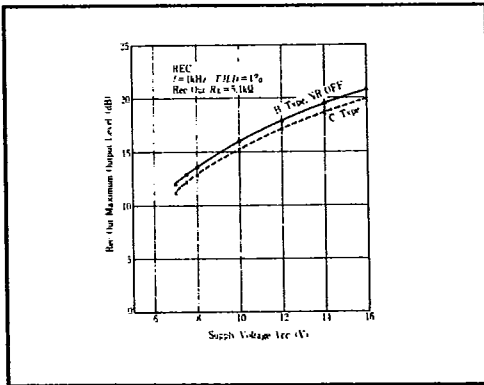

Figure 16 REC Out Maximum Output Level vs Supply Voltage

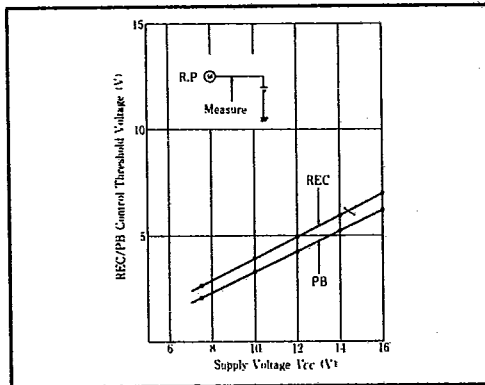

Figure 17 REC/PB Control Threshold Voltage vs Supply Voltage



HA12088ANT/HA12090NT/HA12091AMP

T-77-21

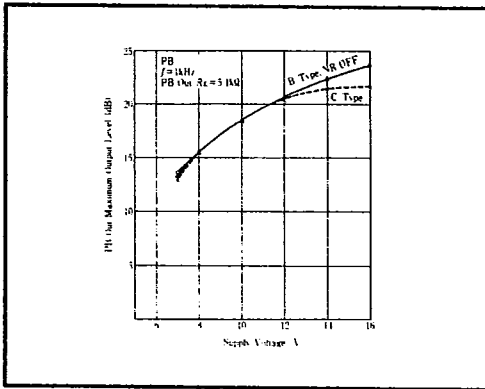

Figure 18 PB Out Maximum Output Level vs Supply Voltage

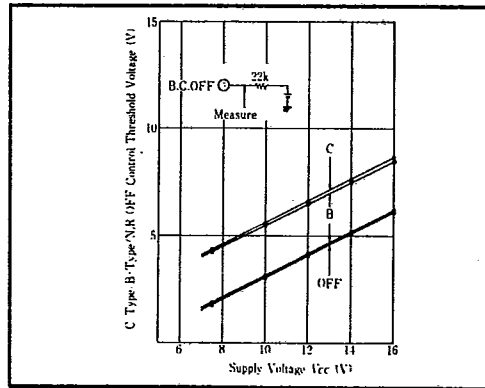

Figure 19 NR Off/B-Type/C-Type Control Threshold Voltage vs Supply Voltage

