



MS4515

SPECIFICATIONS

- ◆ PCB Mounted Pressure Transducers
- ◆ Pressure Ranges from 2 to 30 inches H₂O
- ◆ Amplified Ratiometric Analog Output
- ◆ Differential & Gage
- ◆ Temperature Compensated
- ◆ 3.3V or 5.0 V_{DC} Supply Voltage

FEATURES

- ◆ Inches H₂O Pressure Ranges
- ◆ PCB Mountable
- ◆ High Level Analog Output
- ◆ Barbed Pressure Ports

APPLICATIONS

- ◆ Blocked Filter Detection
- ◆ Altitude and Airspeed Measurements
- ◆ Medical Instruments
- ◆ Fire Suppression System
- ◆ Panel Meter
- ◆ Air Movement/Environmental Controls
- ◆ Pneumatic Controls

The MS4515 is a small, ceramic based, PCB mounted pressure transducer from Measurement Specialties. The transducer is built using the latest CMOS sensor conditioning circuitry to create a low cost, high performance transducer designed to meet the strictest requirements from OEM customers.

The MS4515 is fully calibrated and temperature compensated with a total error band (TEB) of less than 1.0% over the compensated range. The sensor operates from single supply of either 3.3 or 5.0V_{DC} and requires a single external component for proper operation.

The rugged ceramic transducer is available in side port, top port, and manifold mount versions and can measure gage or differential pressure from 2 to 30 inches H₂O. The 1/8" barbed pressure ports mate securely with 3/32" ID tubing.

STANDARD RANGES (INCHES H₂O)

Range	Gage	Differential	Option Availability
2		DS, SS, TP, MM	
4	DS, SS, TP, MM	DS, SS, TP, MM	
5	DS, SS, TP, MM	DS, SS, TP, MM	
10	DS, SS, TP, MM	DS, SS, TP, MM	-F
20	DS, SS, TP, MM	DS, SS, TP, MM	-F
30	DS, SS, TP, MM	DS, SS, TP, MM	-F

See Package Configurations: DS= Dual Side Port, SS= Single Side Port, TP= Top Port, MM= Manifold Mount
 Pin Style "L" is only available SS and MM port types.
 Pin Style "C" is only available SS, TP and MM port types.

BLOCK DIAGRAM

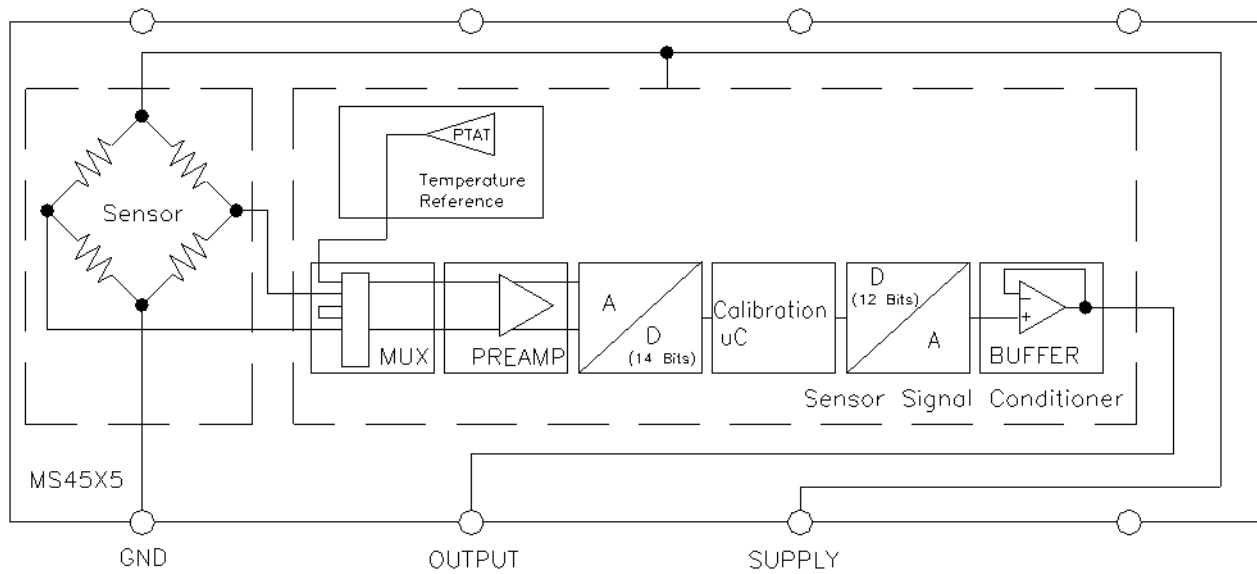

ABSOLUTE MAXIMUM RATINGS

Parameter	Conditions	Min	Max	Unit	Notes
Supply Voltage	T _A = 25 °C	2.7	5.5	V	
Output Current	T _A = 25°C		3	mA	
Load Resistance (R _L)	T _A = 25°C	10		kΩ	
Storage Temperature		-40	+125	°C	
Humidity	T _A = 25°C		95	%RH	Non Condensing
Overpressure	T _A = 25 °C, both Ports	Not to Exceed 300		psi	
Burst Pressure	T _A = 25 °C, Port 1			psi	See Table 1
ESD	HBM	-4	+4	kV	EN 61000-4-2
Solder Temperature		250°C, 5 sec max.			

TABLE 1- BURST PRESSURE BY RANGE AND PACKAGE STYLE

Style	Port	002	004	005	010	020	030	Unit
DS, MM	Port 1	10	10	10	10	10	20	PSI
	Port 2	10	10	10	10	10	20	PSI
SS, TP	Port 1		10	10	10	10	20	PSI

ENVIRONMENTAL SPECIFICATIONS

Parameter	Conditions
Mechanical Shock	Mil Spec 202F, Method 213B, Condition C, 3 Drops
Mechanical Vibration	Mil Spec 202F, Method 214A, Condition 1E, 1Hr Each Axis
Thermal Shock	100 Cycles over Storage Temperature, 30 minute dwell
Life	1 Million FS Cycles
MTTF	>10Yrs, 70 °C, 1.188 Million Pressure Cycles, 120%FS Pressure

PERFORMANCE SPECIFICATIONS

Supply Voltage¹: 5.0V or 3.3 V_{DC}

Ambient Temperature: 25°C (unless otherwise specified)

PARAMETERS	MIN	TYP	MAX	UNITS	NOTES
Output	0.500		4.500	V	1,2,3
	0.250		4.75	V	
Accuracy	-0.25		0.25	%Span	2
Total Error Band (TEB)	-1.0		1.0	%Span	3,5
TEB (4inH ₂ O and Below)	-2.0		2.0	%Span	3,5
Supply Current		3		mA	5
Compensated Temperature	0		+60	°C	4
Operating Temperature	-10		+85	°C	
Response Time		1		ms	5
Start time to data ready			6	ms	
Weight		3		grams	
Media	Non-Corrosive Dry Gases Compatible with Ceramic, Silicon, Borosilicate Glass, RTV, Gold, Aluminum and Epoxy. See "Wetted Material by Port Designation" chart below.				

Notes

1. Proper operation requires an external capacitor placed as shown in Connection Diagram. Output is ratiometric to supply voltage variations of less than 10%.
2. Accuracy: The maximum deviation from a best fit straight line (BFSL) fitted to the output measured over the pressure range at 25°C. Includes all errors due to pressure non linearity, hysteresis, and non-repeatability.
3. Total error band includes all accuracy errors, thermal errors over the compensated temperature range, and span and offset calibration tolerances. For ideal sensor output with respect to input pressure, reference Pressure Transfer Function charts below. TEB values are valid only at the calibrated supply voltage.
4. For errors beyond the compensated temperature range, see Extended Temperature Multiplier chart below.
5. This product can be configured for custom OEM requirements, contact factory for lower power consumption or higher accuracy.

CONNECTION DIAGRAM

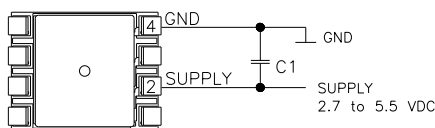

Notes

1. Place 100nF capacitor between Supply and GND to within 2 cm of sensor.

PRESSURE AND TEMPERATURE TRANSFER FUNCTION

Pressure Transfer Functions, Supply=5V

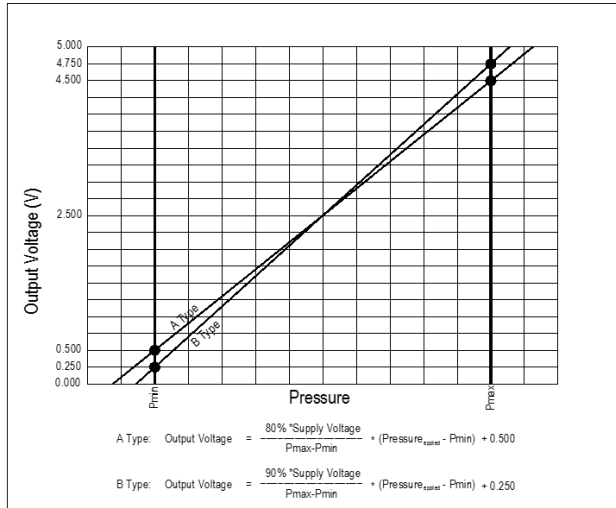

Pressure Transfer Functions, Supply=3.3V

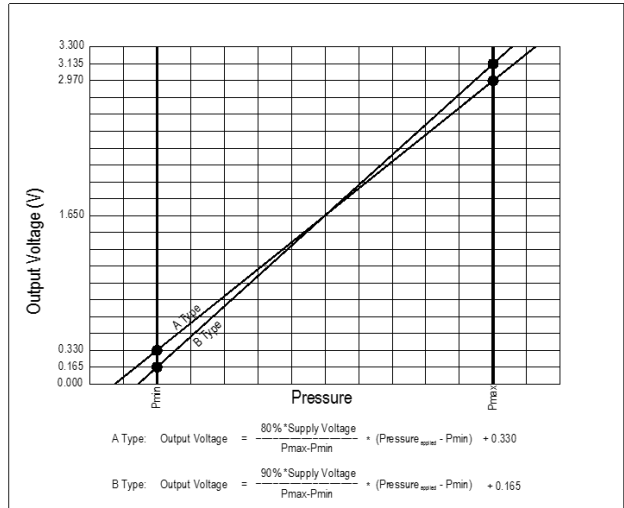

Sensor output at Significant Percentages (5V Supply Voltage)

% Output	Output type A [inH ₂ O]	Output type B [inH ₂ O]	Voltage [V]
0	$P_{\min} - (P_{\max} - P_{\min}) * 10/80$	$P_{\min} - (P_{\max} - P_{\min}) * 5/90$	0.000
5		P_{\min}	0.250
10	P_{\min}		0.500
50			2.500
90	P_{\max}		4.500
95		P_{\max}	4.750
100	$P_{\max} + (P_{\max} - P_{\min}) * 10/80$	$P_{\max} + (P_{\max} - P_{\min}) * 5/90$	5.000

Sensor output at Significant Percentages (3.3V Supply Voltage)

% Output	Output type A [inH ₂ O]	Output type B [inH ₂ O]	Voltage [V]
0	$P_{\min} - (P_{\max} - P_{\min}) * 10/80$	$P_{\min} - (P_{\max} - P_{\min}) * 5/90$	0.000
5		P_{\min}	0.165
10	P_{\min}		0.330
50			1.650
90	P_{\max}		2.970
95		P_{\max}	3.315
100	$P_{\max} + (P_{\max} - P_{\min}) * 10/80$	$P_{\max} + (P_{\max} - P_{\min}) * 5/90$	3.300

EXTENDED TEMPERATURE MULTIPLIER CHART

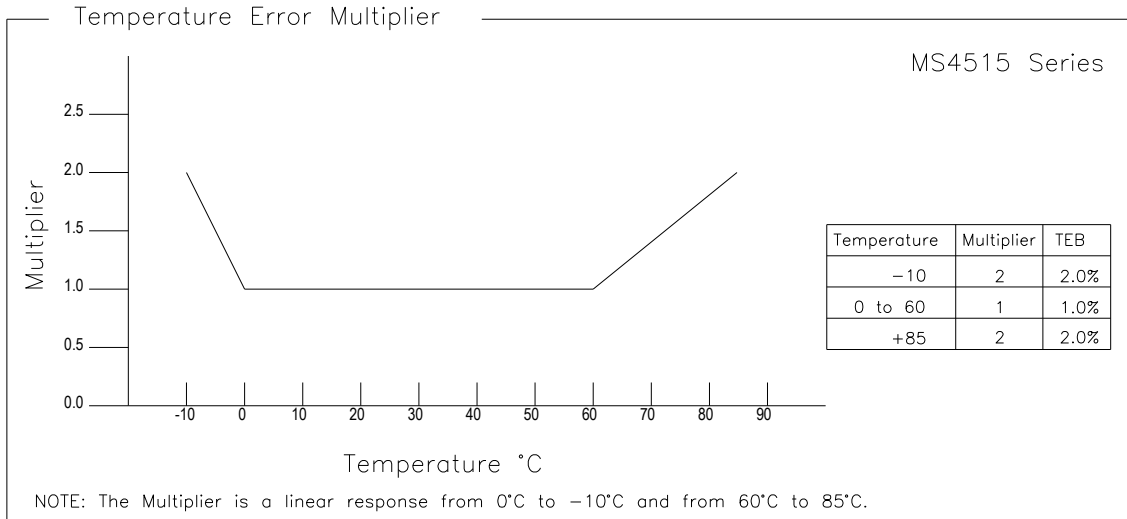

PACKAGE, PINOUT & PRESSURE TYPE CONFIGURATION

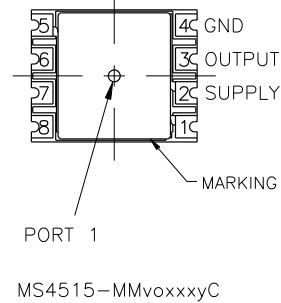
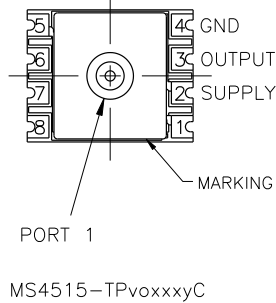
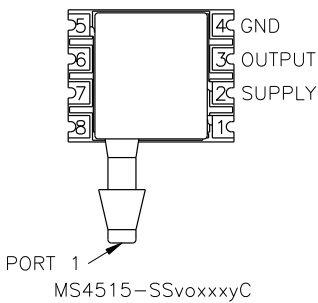
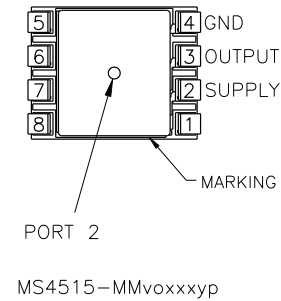
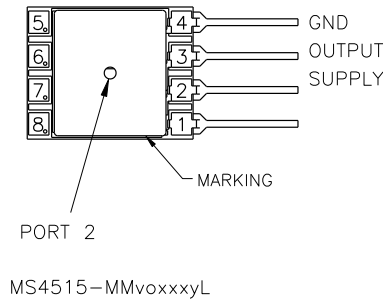
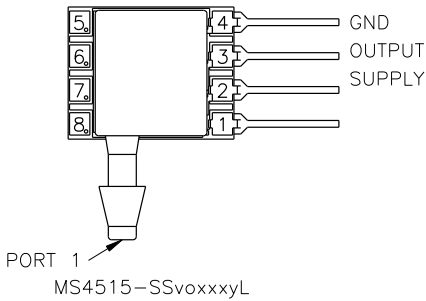
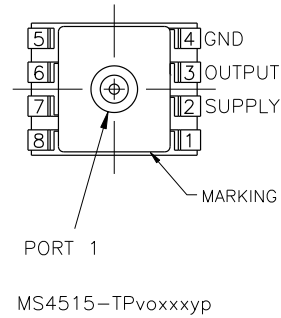
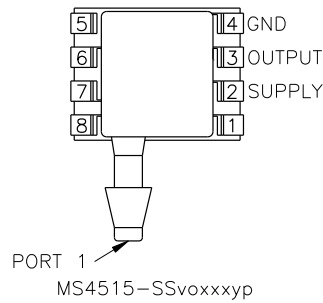
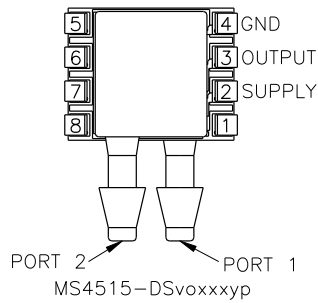

P_{range} is equal to the maximum full scale pressure specified in the ordering information.

Pin Name	Pin	Function
SUPPLY	2	Positive Supply Voltage
OUTPUT	3	Analog Output
GND	4	Ground
	1, 5-8	No Connection

Pressure Type	P_{min}	P_{max}	Description
Differential/ Bidirectional	$-P_{range}$	$+P_{range}$	Output is proportional to the difference between Port 1 and Port 2. Output swings positive when Port 1 > Port 2. Output is 50% of supply voltage when Port 1 = Port 2
Gage	0psiG	$+P_{range}$	Output is proportional to the difference between 0psiG (P_{min}) and Port 1. Output swings positive when Port 1 > Port 2.

WETTED MATERIAL BY PORT DESIGNATION

Style	Port	Material						
		Ceramic	Silicon	Borosilicate Glass	RTV	Gold	Aluminum	Epoxy
DS, MM	Port 1	X	X	X	X			X
	Port 2	X	X	X	X	X	X	X
SS, TP,SM	Port 1	X	X	X	X	X	X	X

"X" Indicates Wetted Material

DIMENSIONS (are in INCHES [mm])

Model: MS4515-DSvoxxxxyP

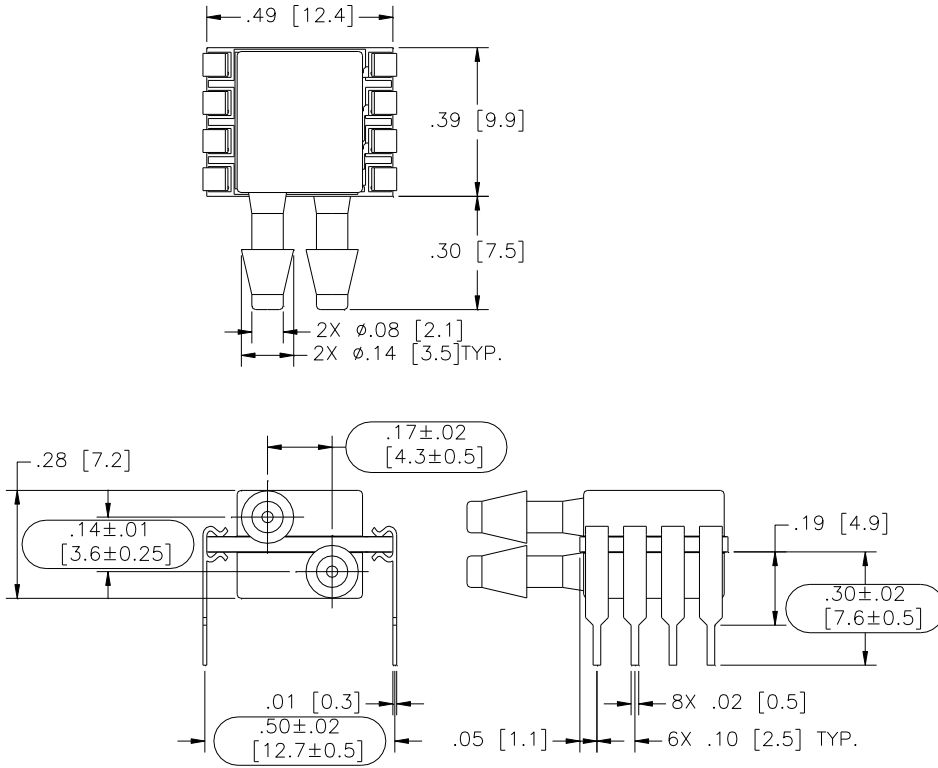

Model: MS4515-DSvoxxxxyS

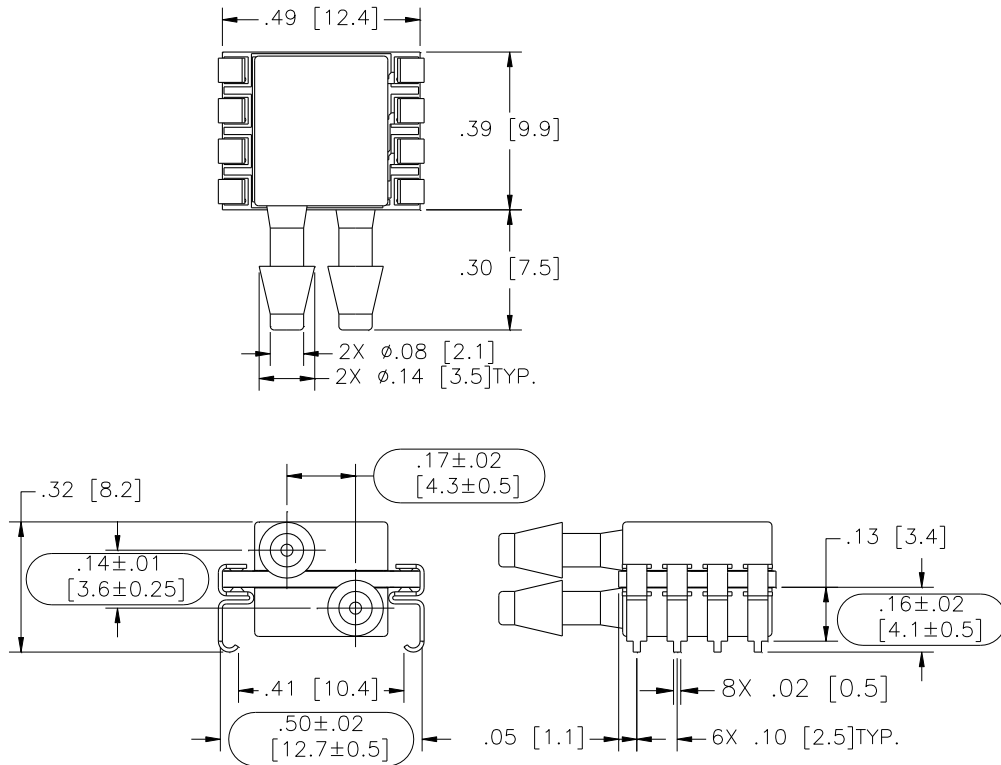

MS4515

Model: MS4515-SSvoxxxxyP

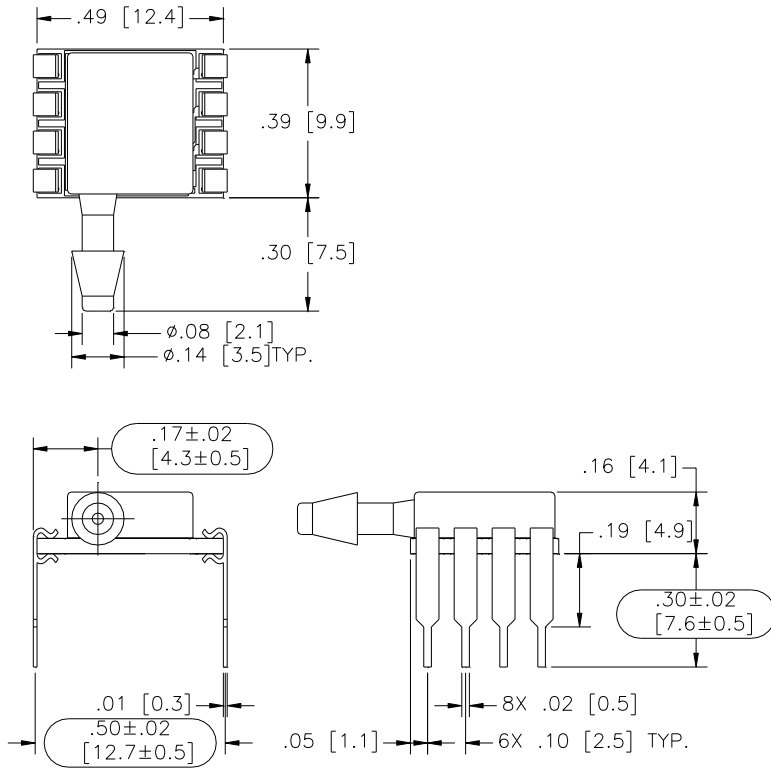

Model: MS4515-SSvoxxxxyS

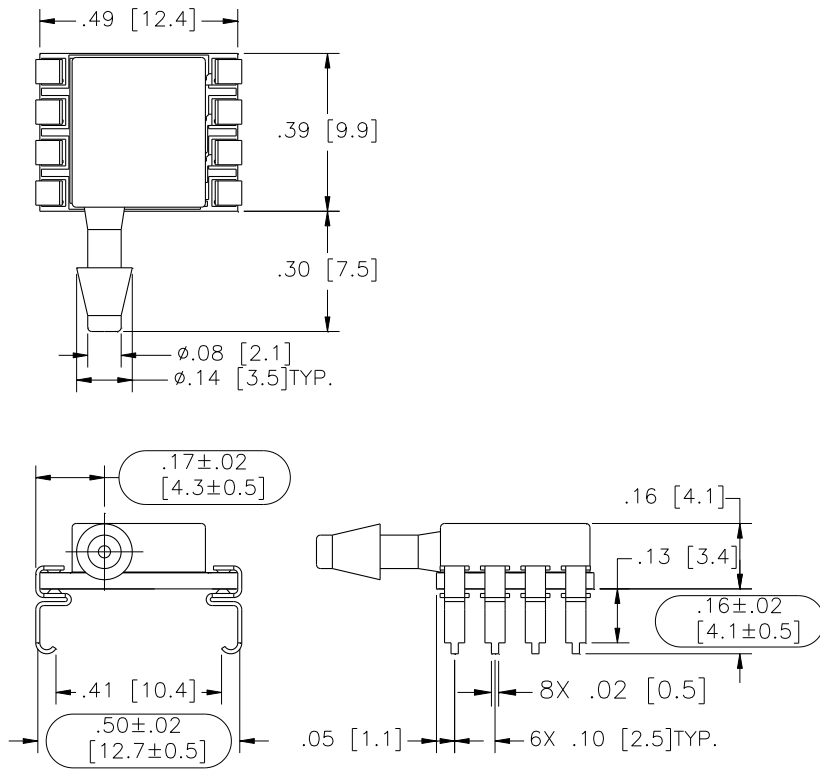

Model: MS4515-TPvoxxxxyP

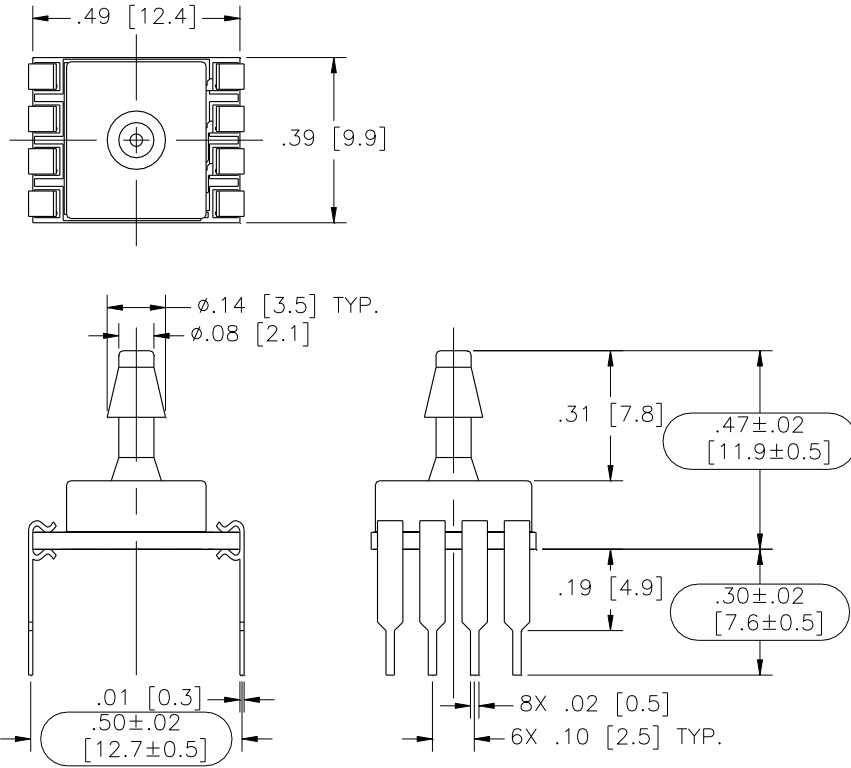

Model: MS4515-TPvoxxxxyS

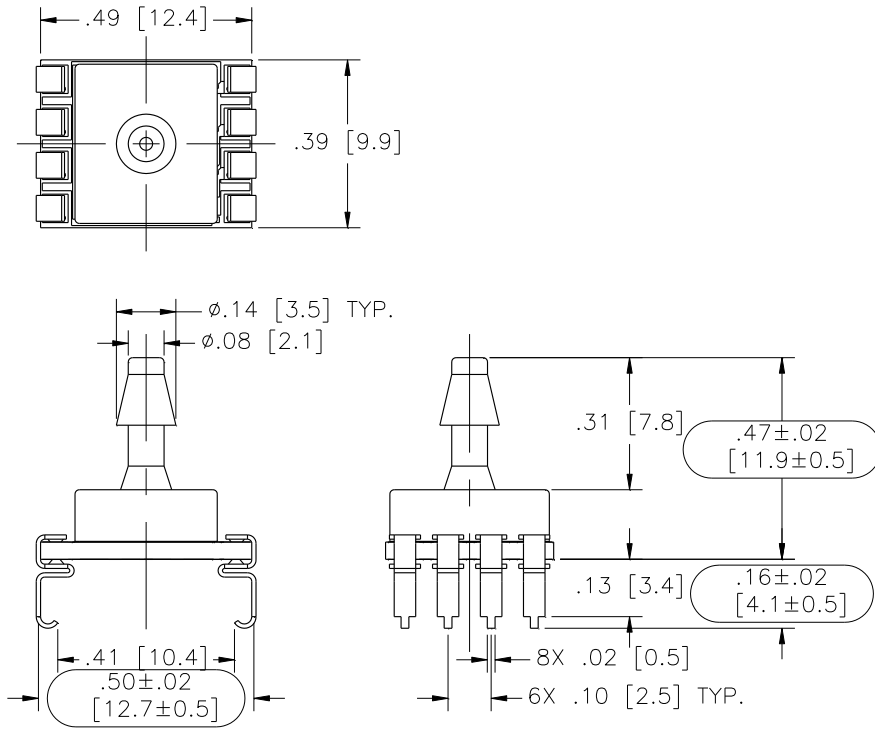

MS4515

Model: MS4515-SSvoxxxxyl

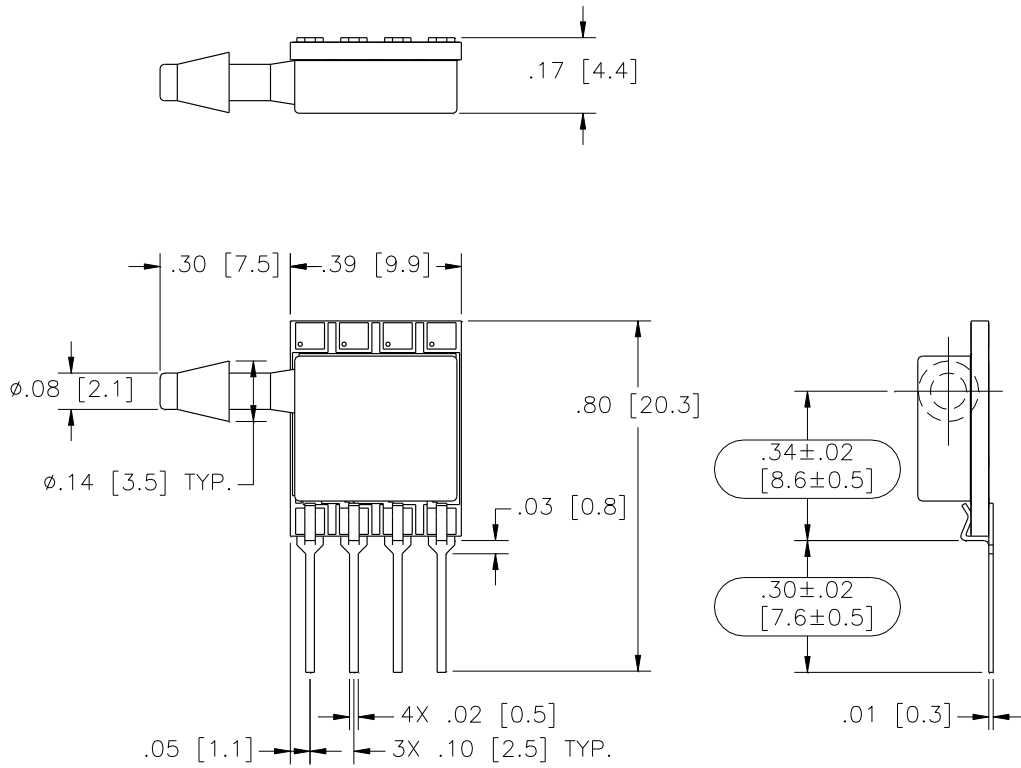

Model: MS4515-MMvoxxxxyl

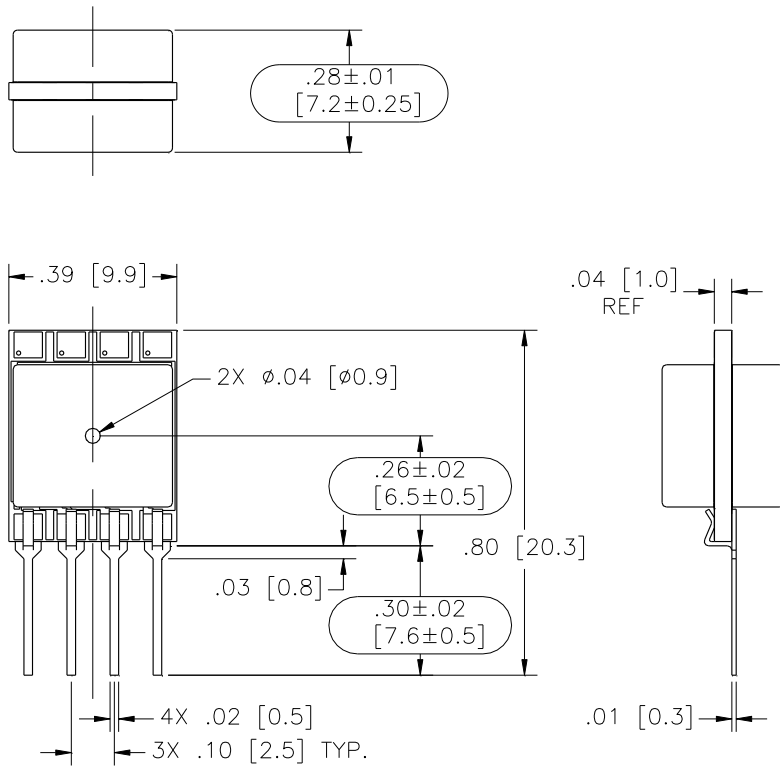

Model: MS4515-MMvoxxxyP

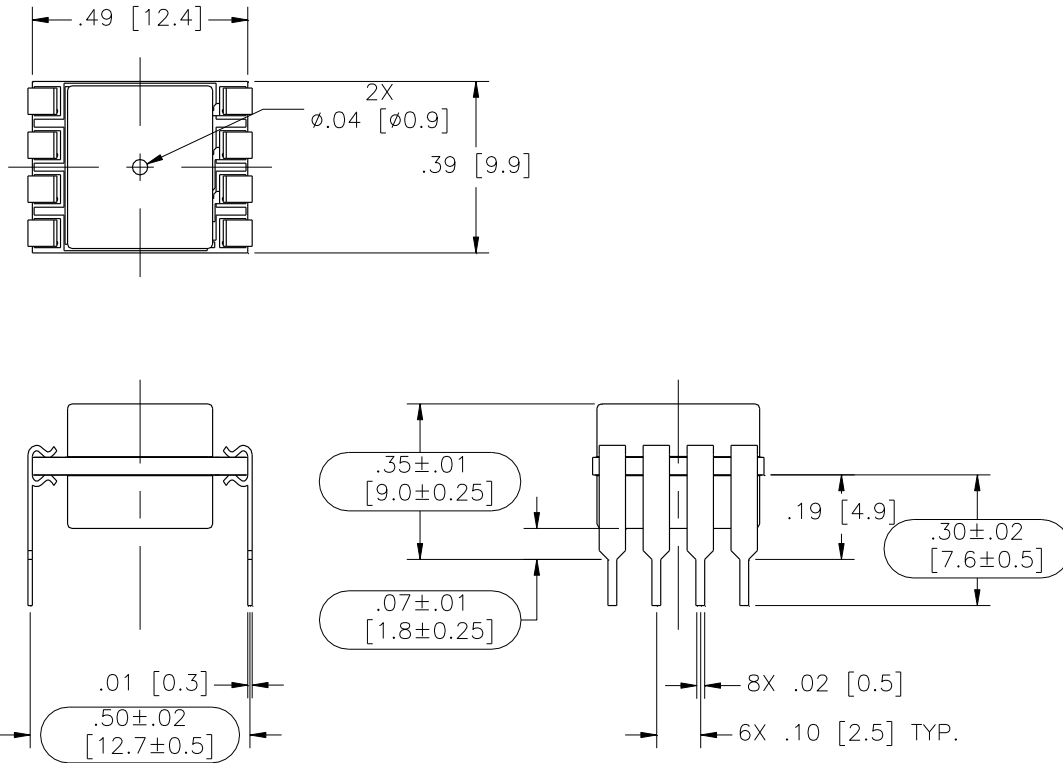

Model: MS4515-MMvoxxxyS

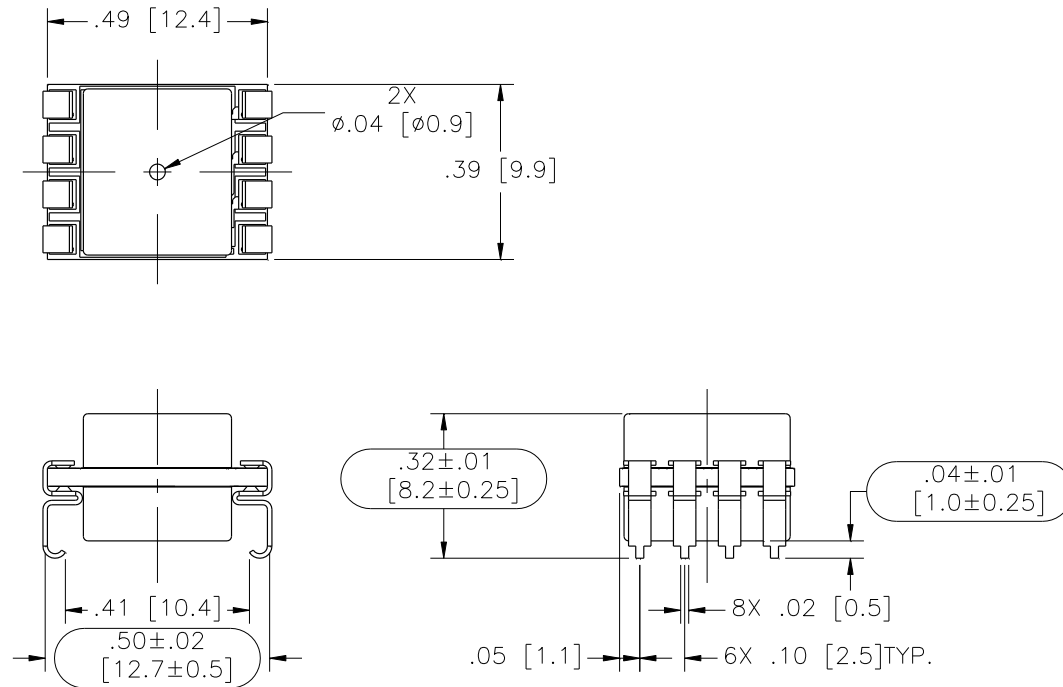

Model: MS4515-SSvoxxxyC

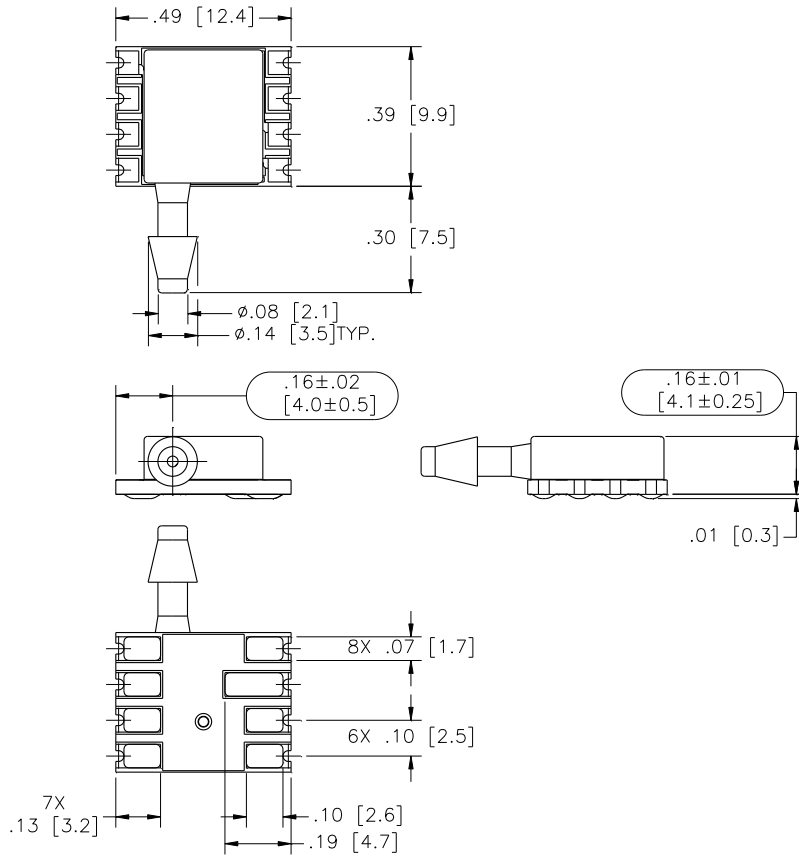

Model: MS4515-TPvoxxxyC

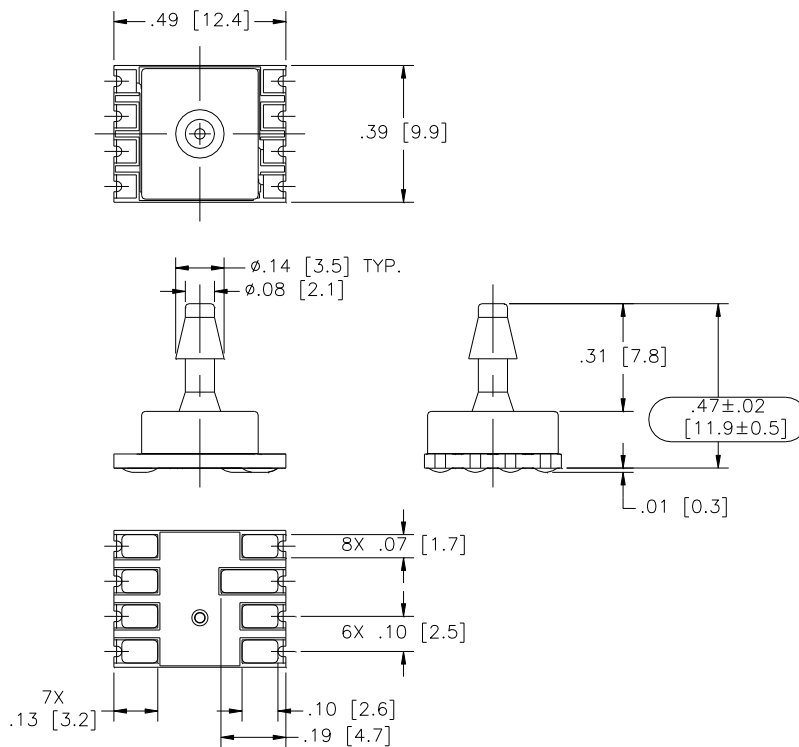

Model: MS4515-MMvoxxxyC

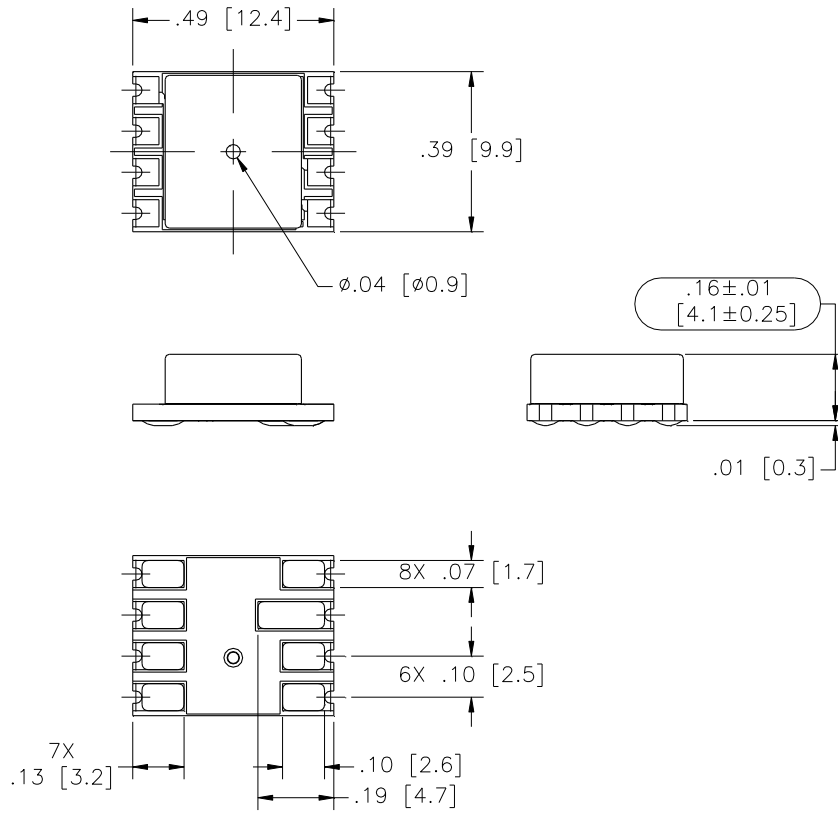

AVAILABLE OPTIONS

Gel Coat (-F Option)

The MS4515 is designed for non-ionic and clean dry air applications. Select this option for added protection in high humidity or slightly corrosive environments with the application of a silicone gel elastomer to sensor and ASIC. For questions concerning media compatibility, contact the factory.

ORDERING INFORMATION

4515 – DS 3 A 030 D P F

Electrical	
SS	Single Sideport
DS	Dual Sideport
TP	Top Port
MM	Manifold Mount

Supply Voltage	
3	3.3 V _{DC}
5	5.0 V _{DC}

Output Type	
A	10% - 90%
B	5% to 95%

Pressure Range [inH ₂ O]
002
004
005
010
020
030

Option Type	
[Blank]	No Option
F*	Gel Coating

*Options available for pressure ranges ≥10inH₂O

Fitting Type	
P	Thru Hole
S	J Lead
L	In Line
C	Castellation

Pressure Type	
D	Differential
G	Gauge

NORTH AMERICA

Measurement Specialties, Inc.,
a TE Connectivity company
Tel: 800-522-6752
Email: customercare.frmt@te.com

EUROPE

Measurement Specialties (Europe), Ltd.,
a TE Connectivity Company
Tel: 800-440-5100
Email: customercare.bevx@te.com

ASIA

Measurement Specialties (China) Ltd.,
a TE Connectivity company
Tel: 0400-820-6015
Email: customercare.shzn@te.com

TE.com/sensorsolutions

Measurement Specialties, Inc., a TE Connectivity company.

Measurement Specialties, TE Connectivity, TE Connectivity (logo) and EVERY CONNECTION COUNTS are trademarks. All other logos, products and/or company names referred to herein might be trademarks of their respective owners.

The information given herein, including drawings, illustrations and schematics which are intended for illustration purposes only, is believed to be reliable. However, TE Connectivity makes no warranties as to its accuracy or completeness and disclaims any liability in connection with its use. TE Connectivity's obligations shall only be as set forth in TE Connectivity's Standard Terms and Conditions of Sale for this product and in no case will TE Connectivity be liable for any incidental, indirect or consequential damages arising out of the sale, resale, use or misuse of the product. Users of TE Connectivity products should make their own evaluation to determine the suitability of each such product for the specific application.

© 2015 TE Connectivity Ltd. family of companies All Rights Reserved.