

- 1
- 2
- 3
- 4
- 5
- 6
- 7
- 8
- 9
- 10
- 11
- 12
- 13
- 14
- 15
- 16
- 17
- 18

LEVER BODY

Turned and black-oxide steel.

HANDLE

Phenolic based (PF) Duroplast, black colour, glossy finish I.280 (see page 560).

STANDARD EXECUTIONS

- **GN 216-C:** H7 reamed blind hole
- **GN 216-E:** threaded blind hole.

SPECIAL EXECUTIONS ON REQUEST

AISI 303 stainless steel with threaded blind hole for diameters D = 22 - 25 - 28 - 32.

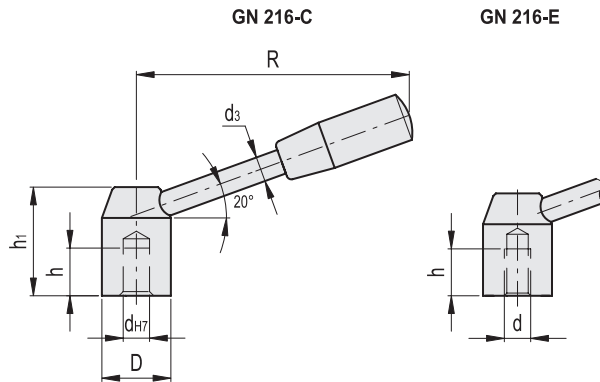

GN 216-C

Code	Description	D	dh7	R	h	h1	d3	⚖
GN.10314	GN 216-22-B10-C	22	10	83	19	37	8	114
GN.10324	GN 216-25-B12-C	25	12	102	21	42	10	173
GN.10333	GN 216-28-B12-C	28	12	116	23	47	12	266
GN.10344	GN 216-32-B16-C	32	16	132	25	52	12	341
GN.10355	GN 216-36-B16-C	36	16	147	27	58	14	499
GN.10365	GN 216-40-B20-C	40	20	163	29	64	16	679

GN 216-E

Code	Description	D	d	R	h	h1	d3	⚖
GN.10311	GN 216-22-M10-E	22	M10	83	15	37	8	118
GN.10321	GN 216-25-M12-E	25	M12	102	18	42	10	181
GN.10331	GN 216-28-M12-E	28	M12	116	18	47	12	265
GN.10341	GN 216-32-M16-E	32	M16	132	23	52	12	344
GN.10351	GN 216-36-M16-E	36	M16	147	24	58	14	500
GN.10361	GN 216-40-M20-E	40	M20	163	27	64	16	664