

E43377

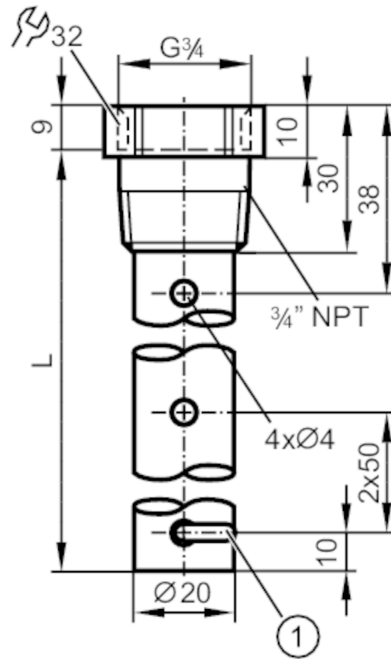

Coaxial pipe for level sensors

LR COAX TUBE NPT L240



CRN

Application	
Design	for level sensors LR
Medium temperature [°C]	-40...200
MAWP (for applications according to CRN) [bar]	16
Mechanical data	
Weight [g]	188.5
Materials	Coaxial pipe: stainless steel (1.4301 / 304); fixing bracket: stainless steel (1.4310 / 301); Centring piece: PPS reinforced fibre
Sensor connection	threaded connection G 3/4 internal thread
Process connection	threaded connection 3/4" NPT external thread
Length [mm]	240
Remarks	
Pack quantity	1 pcs.