

# E3M159

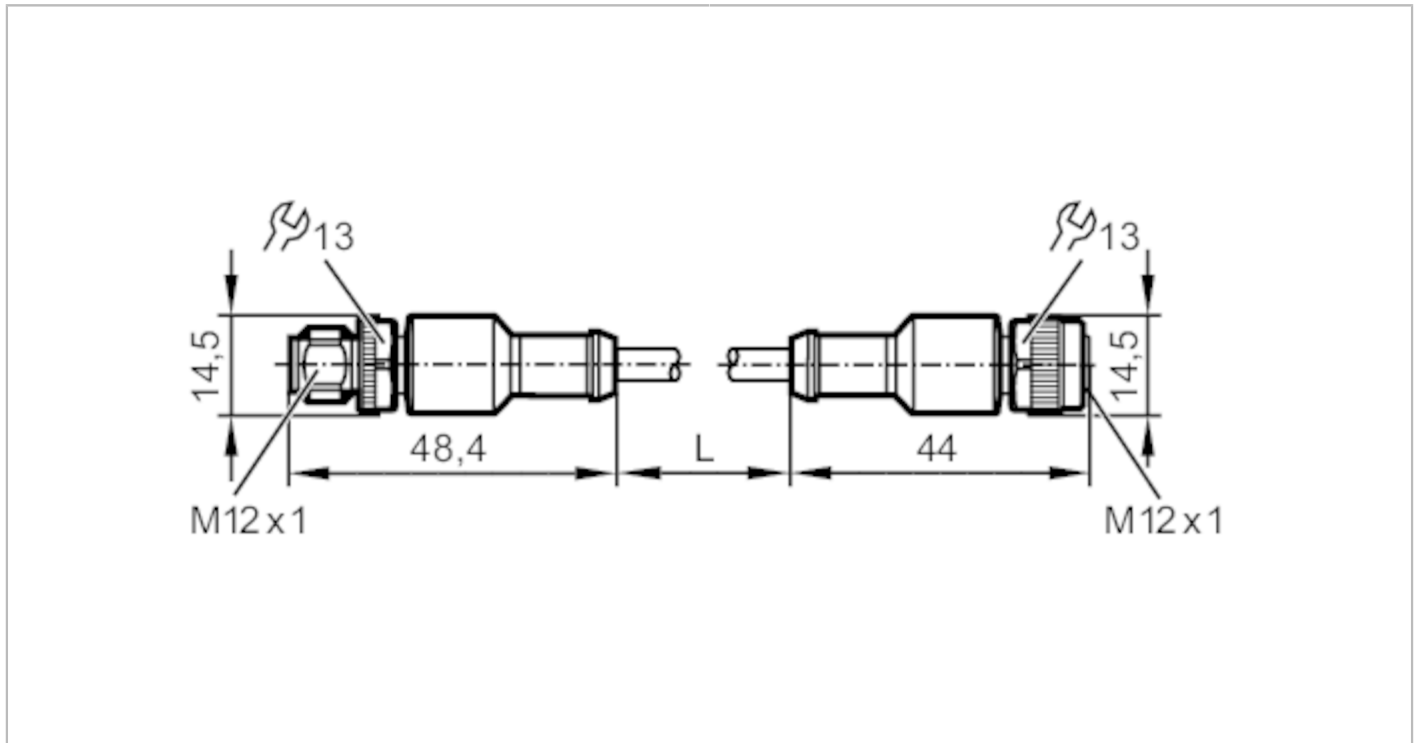

## Connection cable 3D sensor - illumination unit

CONNECTION CABLE M12 5M EXT.



Application	
Special feature	Screened cable; Drag chain suitability
Design	Extension for O3M connection cable
Electrical data	
Operating voltage [V]	< 50 AC / < 60 DC
Protection class	III
Operating conditions	
Ambient temperature [°C]	-40...80
Protection	IP 67; IP 69K
Mechanical data	
Weight [g]	281.2
Dimensions [mm]	14.5 x 14.5 x 48.4
Materials	housing: PUR; Sealing: FKM; contact pins: CuSn6 nickel-plated and tin-plated
Material nut	stainless steel (1.4305 / 303) / stainless steel (1.4305 / 303)
Drag chain suitability	yes
Drag chain suitability	bending radius for fixed installation ≥ 60 mm
Remarks	
Pack quantity	1 pcs.

**Electrical connection**  
 Cable: 5 m, TPU, black, Ø 6 mm, shielded; Impedance 75 Ω

**Electrical connection - plug**  
 Connector: 1 x M12, straight; Locking: stainless steel (1.4305 / 303)

# E3M159



## Connection cable 3D sensor - illumination unit

CONNECTION CABLE M12 5M EXT.

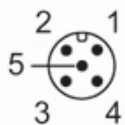

### Connection

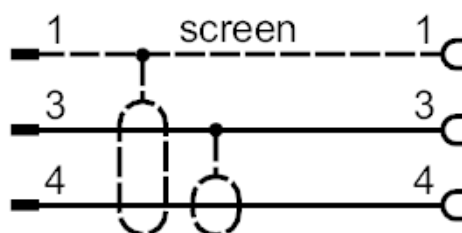

- 1: screen
- 2: not used
- 3: coax screen
- 4: coax cable core
- 5: not used

### Electrical connection - socket

Connector: 1 x M12, straight; Locking: stainless steel (1.4305 / 303)

