

LMT302

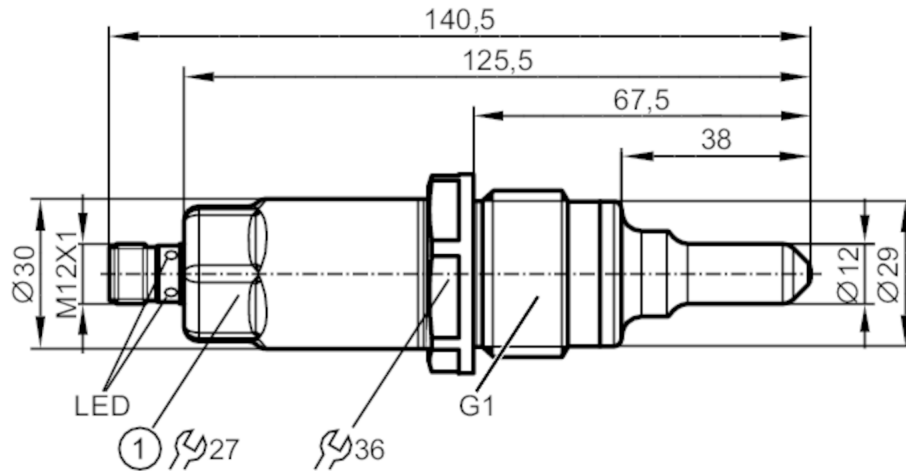

Sensor for point level detection

LMCCE-A01E-QSKG-2/US



1 Tightening torque 35 Nm

ACS CE cUL^{us} LISTED EAC EC 1935/2004 FDA IO-Link

Product characteristics

Number of inputs and outputs	Number of digital outputs: 2
Factory setting	hydrous media
Process connection	G 1 external thread

Application

Special feature	Gold-plated contacts
Installation	suited for installation in existing tuning fork adapters
Media	Liquids; viscous media; powder
Recommended media	water; hydrous media; oils; oil-based media; powder
Cannot be used for	See the operating instructions, chapter "Function and features".
Probe length [mm]	38
Tank pressure [bar]	-1...40

Oil	
Medium temperature [°C]	-20...100
Medium temperature short time [°C]	-20...150; (1 h)
Water	
Medium temperature [°C]	-20...100
Medium temperature short time [°C]	-20...150; (1 h)

Electrical data

Operating voltage [V]	18...30 DC
Current consumption [mA]	< 50
Protection class	III
Reverse polarity protection	yes

Inputs / outputs

Number of inputs and outputs	Number of digital outputs: 2
------------------------------	------------------------------

LMT302



Sensor for point level detection

LMCCE-A01E-QSKG-2/US

Outputs		
Total number of outputs		2
Output signal		switching signal; IO-Link
Electrical design		PNP/NPN
Number of digital outputs		2
Output function		normally open / normally closed; (parameterisable)
Max. voltage drop switching output DC	[V]	2.5
Permanent current rating of switching output DC	[mA]	100
Short-circuit protection		yes
Type of short-circuit protection		pulsed
Overload protection		yes
Measuring/setting range		
Factory setting		hydrous media
Response times		
Response time	[s]	< 0.5
Interfaces		
Communication interface		IO-Link
Transmission type		COM2 (38,4 kBaud)
IO-Link revision		1.1
SDCI standard		IEC 61131-9
IO-Link device ID		0x000172
Profiles		Smart Sensor: Process Data Variable; Device Identification
SIO mode		yes
Required master port type		A
Process data analogue		1
Process data binary		2
Min. process cycle time	[ms]	2.3
Operating conditions		
Ambient temperature	[°C]	-20...85
Note on ambient temperature		Medium temperature: < 100 °C
		-20...60 °C
Storage temperature	[°C]	Medium temperature: < 150 °C
		-40...85
Protection		IP 68; IP 69K
Tests / approvals		
EMC	DIN EN 61000-6-2	: 2006
	DIN EN 61000-6-4	: 2011 / open tanks
	DIN EN 61000-6-3	: 2011 / closed tanks
Shock resistance	DIN EN 60068-2-27	50 g (11 ms)
Vibration resistance	DIN EN 60068-2-6	20 g (10...2000 Hz)
MTTF	[years]	223
UL approval	UL Approval no.	H001

LMT302



Sensor for point level detection

LMCCE-A01E-QSKG-2/US

Mechanical data	
Weight [g]	391
Dimensions [mm]	Ø 30 / L = 125.5
Materials	stainless steel (1.4404 / 316L); PEEK; PEI; FKM
Materials (wetted parts)	PEEK
Process connection	G 1 external thread
Surface characteristics Ra/Rz of the wetted parts	< 0.8

Displays / operating elements		
Display	switching status	LEDs, yellow
	operating status	LEDs, green

Remarks	
Pack quantity	1 pcs.

Electrical connection

Connector: 1 x M12; Contacts: gold-plated



Connection

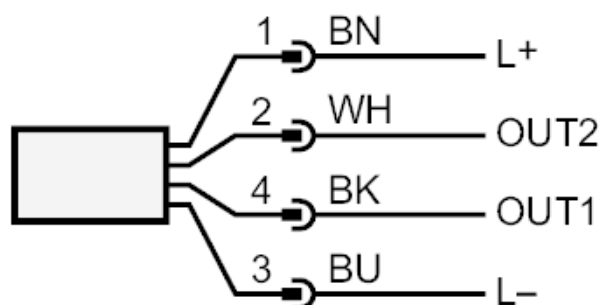

OUT1: switching output IO-Link Teach

OUT2: switching output

colours to DIN EN 60947-5-2