

SOFTWARE



TECHNICAL DATA

<b>Operating voltage</b>	12 V to 24 VDC
<b>Phase current</b>	Nominal current 1.8 A, adjustable up to 2.7 A
<b>Interface</b>	RS485 4-wire or CANopen
<b>Operating type</b>	RS485: position, speed, flag position, clock-direction, analog, joystick CANopen: position, homing mode, velocity mode, interpolated position mode (as per CAN standard DS402)
<b>Operating mode</b>	1/1, 1/2, 1/4, 1/5, 1/8, 1/10, 1/32, 1/64, adaptive, feed constant
<b>Step frequency</b>	16 kHz in full step; in microstep, corresponding multiples (e.g. up to 1 MHz at 1/64)
<b>Inputs</b>	6 digital inputs (TTL), 1 analog input +10/-10V
<b>Outputs</b>	3 open collector, 24 V/0.5 A max.
<b>Current reduction</b>	Adjustable 0 – 100%
<b>Protective circuit</b>	Overvoltage, undervoltage and temperature >80 °C
<b>Temperature range</b>	0 to +40 °C

VERSIONS

Type	Min. Operating Voltage V	Max. Operating Voltage V	Nominal Current A	Controller for	Interface	Weight kg
SMCI12	12	24	1.8	Stepper Motors	RS485, CANopen	0.05

ORDER IDENTIFIER

**SMCI12-**  
2 = RS485 Interface  
3 = CANopen Interface

ACCESSORIES

**ZK-RS485-USB** Converters  
**Z-K4700/50** Charging Capacitor  
**ZK-SMCI12** RS485 Cable  
**ZK-SMCI12-3** CANopen Cable  
**ZK-SMCI12-IO** IO Cable  
**ZK-XHP-4-300** Motor Cable

CAUTION

We recommend using a back-up capacitor of sufficient size to stabilize the operating voltage.

DIMENSIONS (IN MM)

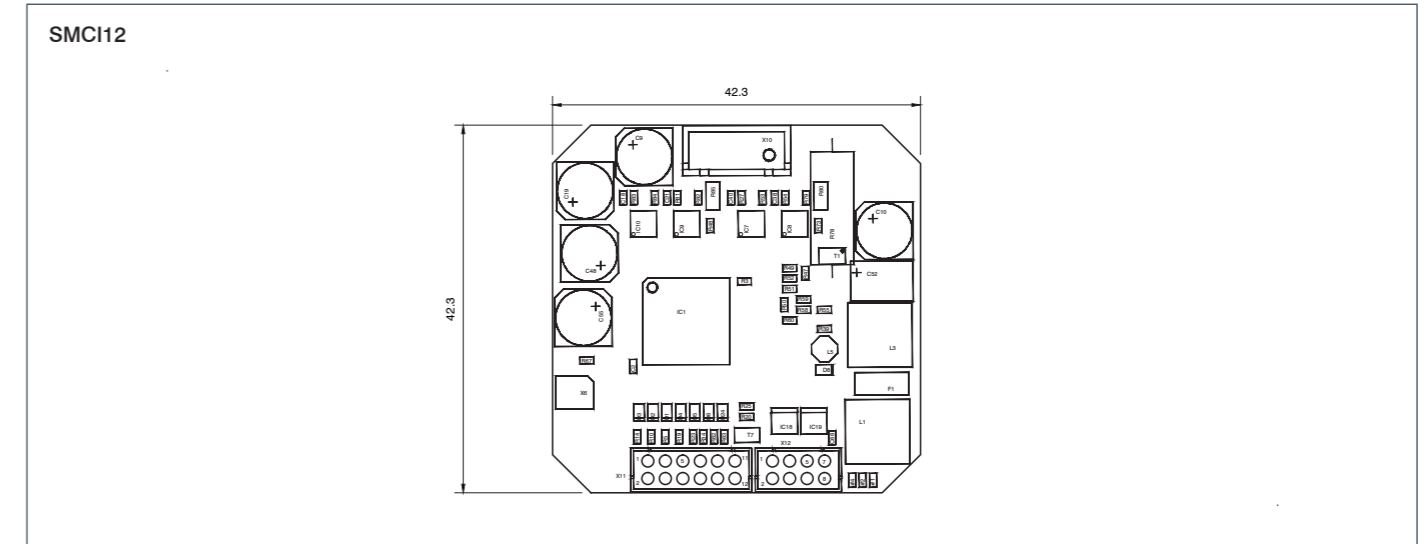

INPUTS/OUTPUTS (X11)

Pin	Function*
1	GND
2	Input 1
3	Input 2
4	Input 3
5	Input 4
6	Input 5
7	Input 6
8	Analog In
9	Output 1
10	Output 2
11	Output 3
12	GND

EINGANGSBESCHALTUNG

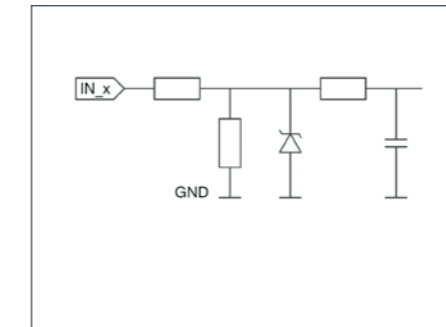

SUPPLY/COMMUNICATION (X12)

Pin	Function*
	<b>RS485</b> <b>CANopen</b>
1	GND      GND
2	GND      GND
3	RX+      n.c.
4	RX-      n.c.
5	TX-      CAN low (CAN-)
6	TX+      CAN high (CAN+)
7	GND      GND
8	UB 12-24 VDC      UB 12-24 VDC

MOTOR CONNECTION (X3)

Pin	Function*
1	Motor Coil A
2	Motor Coil A\
3	Motor Coil B
4	Motor Coil B\

\* from the perspective of the connected controller:  
Connection cable for motors with 6 or 8 connectors:  
ZK-XHP-4-300