



## Features

- Radial leaded devices
- Cured, flame retardant epoxy polymer insulating material meets UL 94V-0 requirements
- RoHS compliant\*
- Agency recognition:   

## Applications

- Almost anywhere there is a load to be protected with a voltage supply of up to 90 V, including:
- Broadband cable power passing taps
  - Set-top boxes

# MF-R/90 Series - PTC Resettable Fuses

### Electrical Characteristics

Model	V max. Volts	I max. Amps	$I_{hold}$		$I_{trip}$		Initial Resistance Values		One Hour Post-Trip Resistance Standard Trip	Max. Time to Trip		Nominal Tripped Power Dissipation
			Amperes at 23 °C		Ohms at 23 °C		Ohms at 23 °C	Amperes at 23 °C	Seconds at 23 °C	Watts at 23 °C		
			Hold	Trip	Min.	Max.	Max.			Typ.		
MF-R055/90	90	10	0.55	1.1	0.45	0.9	2.0	1.6	60	2.0		
MF-R055/90U	90	10	0.55	1.1	0.45	0.9	2.0	1.6	28	2.0		
MF-R075/90	90	10	0.75	1.5	0.37	0.75	1.65	2.0	60	2.5		

\*"U" suffix indicates product without insulation coating.

### Environmental Characteristics

Operating/Storage Temperature .....	-40 °C to +85 °C
Maximum Device Surface Temperature	
in Tripped State .....	125 °C
Passive Aging .....	+85 °C, 1000 hours.....±5 % typical resistance change
Humidity Aging .....	+85 °C, 85 % R.H. 1000 hours.....±5 % typical resistance change
Thermal Shock .....	+125 °C to -55 °C, 10 times.....±10 % typical resistance change
Solvent Resistance .....	MIL-STD-202, Method 215.....No change
Vibration .....	MIL-STD-883C, Method 2007.1.....No change Condition A

### Test Procedures And Requirements For Model MF-R/90 Series

Test	Test Conditions	Accept/Reject Criteria
Visual/Mech .....	Verify dimensions and materials .....	Per MF physical description
Resistance .....	In still air @ 23 °C .....	$R_{min} \leq R \leq R_{max}$
Time to Trip .....	5 times $I_{hold}$ , $V_{max}$ , 23 °C .....	$T \leq \text{max. time to trip (seconds)}$
Hold Current .....	30 min. at $I_{hold}$ .....	No trip
Trip Cycle Life .....	$V_{max}$ , $I_{max}$ , 100 cycles .....	No arcing or burning
Trip Endurance .....	$V_{max}$ , 48 hours .....	No arcing or burning

UL File Number .....	E 174545S
CSA File Number .....	CA 110338
TÜV File Number .....	R2057213

### Thermal Derating Chart - $I_{hold}$ / $I_{trip}$ (Amps)

Model	Ambient Operating Temperature								
	-40 °C	-20 °C	0 °C	23 °C	40 °C	50 °C	60 °C	70 °C	85 °C
MF-R055/90	0.85 / 1.7	0.75 / 1.5	0.65 / 1.3	0.55 / 1.1	0.45 / 0.9	0.4 / 0.8	0.35 / 0.7	0.3 / 0.6	0.22 / 0.44
MF-R055/90U	0.85 / 1.7	0.75 / 1.5	0.65 / 1.3	0.55 / 1.1	0.45 / 0.9	0.4 / 0.8	0.35 / 0.7	0.3 / 0.6	0.22 / 0.44
MF-R075/90	1.15 / 2.3	1.0 / 2.0	0.9 / 1.8	0.75 / 1.5	0.61 / 1.22	0.55 / 1.1	0.48 / 0.96	0.41 / 0.82	0.30 / 0.6

\*RoHS Directive 2002/95/EC Jan. 27, 2003 including annex and RoHS Recast 2011/65/EU June 8, 2011. Specifications are subject to change without notice.

The device characteristics and parameters in this data sheet can and do vary in different applications and actual device performance may vary over time. Users should verify actual device performance in their specific applications.

## Additional Features

- Bulk packaging, tape and reel and Ammo-Pak available on most models

# MF-R/90 Series - PTC Resettable Fuses

# BOURNS®

### Product Dimensions

Model	A Max.	B Max.	C (Pitch) Nom.	D Min.	E Max.	Physical Characteristics		
						Style	Lead Dia.	Material
MF-R055/90	$\frac{10.9}{(0.43)}$	$\frac{16.7}{(0.65)}$	$\frac{5.1 \pm 0.7}{(0.201 \pm 0.028)}$	$\frac{6.3}{(0.248)}$	$\frac{3.6}{(0.142)}$	1	$\frac{0.81}{(0.032)}$	Sn/Cu
MF-R055/90U	$\frac{10.3}{(0.4)}$	$\frac{16.7}{(0.65)}$	$\frac{5.1 \pm 0.7}{(0.201 \pm 0.028)}$	$\frac{6.3}{(0.248)}$	$\frac{3.0}{(0.118)}$	1	$\frac{0.81}{(0.032)}$	Sn/Cu
MF-R075/90	$\frac{11.9}{(0.47)}$	$\frac{15.5}{(0.61)}$	$\frac{5.1 \pm 0.7}{(0.201 \pm 0.028)}$	$\frac{6.3}{(0.248)}$	$\frac{3.6}{(0.142)}$	1	$\frac{0.81}{(0.032)}$	Sn/Cu

Packaging options:

BULK: 500 pcs. per bag. TAPE & REEL: 1500 pcs. per reel. AMMO-PACK: 1000 pcs. per pack

DIMENSIONS:  $\frac{\text{MM}}{\text{(INCHES)}}$

### Style 1

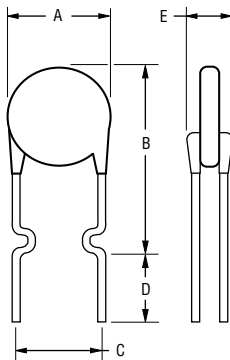

Also available with straight leads.

### Typical Part Marking

Represents total content. Layout may vary.

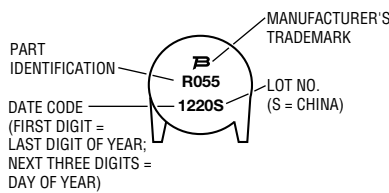

### How to Order

**MF - R 055/90 U - 0**

Multifuse®  
 Product Designator \_\_\_\_\_  
 Series \_\_\_\_\_  
 R = Radial Leaded Component  
 Hold Current, I<sub>hold</sub> \_\_\_\_\_  
 055, 075 (0.55 Amps - 0.75 Amps)  
 Max. Voltage, V \_\_\_\_\_  
 Coating \_\_\_\_\_  
 \_ = Coated  
 U = Uncoated  
 Packaging Options \_\_\_\_\_  
 - 0 = Bulk Packaging  
 - 2 = Tape and Reel\*  
 - AP = Ammo-Pak\*  
 \*Packaged per EIA486-B

### Typical Time to Trip at 23 °C

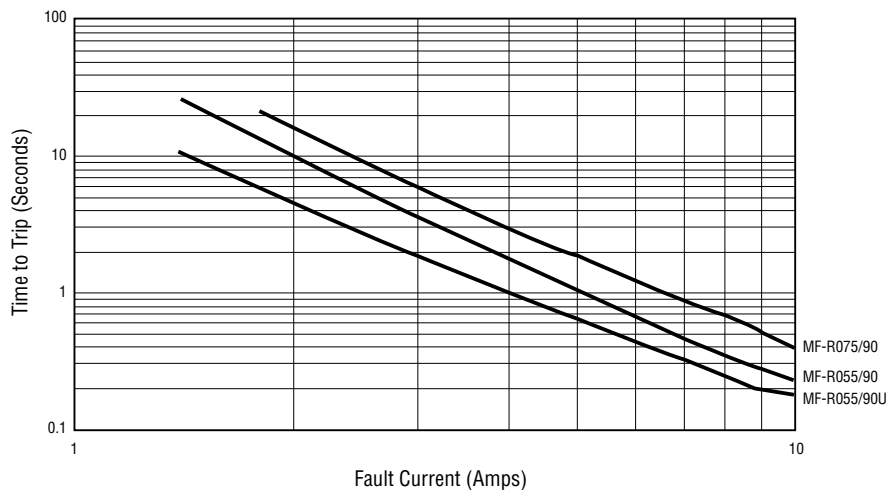

MF-R/90, REV. H 04/14

Specifications are subject to change without notice.

The device characteristics and parameters in this data sheet can and do vary in different applications and actual device performance may vary over time. Users should verify actual device performance in their specific applications.

## MF-R, MF-R/90, MF-R/600, MF-RX, & MF-RX/72 Series Tape and Reel Specifications

**BOURNS®**

Devices taped using EIA468-B/IEC286-2 standards. See table below and Figures 1 and 2 for details.

Dimension Description	IEC Mark	EIA Mark	Dimensions	
			Dimensions	Tolerance
Carrier tape width	$W$	$W$	$\frac{18}{(.709)}$	$\frac{-0.5/+1.0}{(-0.02/+0.039)}$
Hold down tape width	$W_0$	$W_4$	$\frac{11}{(.433)}$	min.
Hold down tape			No protrusion	
Top distance between tape edges	$W_2$	$W_6$	$\frac{3}{(.118)}$	max.
Sprocket hole position	$W_1$	$W_5$	$\frac{9}{(.354)}$	$\frac{-0.5/+0.75}{(-0.02/+0.03)}$
Sprocket hole diameter	$D_0$	$D_0$	$\frac{4}{(.157)}$	$\frac{\pm 0.2}{(\pm .0078)}$
Abscissa to plane (straight lead)	$H$	$H$	$\frac{18.5}{(.728)}$	$\frac{\pm 3.0}{(\pm .118)}$
Abscissa to plane (kinked lead)	$H_0$	$H_0$	$\frac{16}{(.63)}$	$\frac{\pm 0.5}{(\pm .02)}$
Abscissa to top (straight lead)	$H_1$	$H_1$	$\frac{38.0}{(1.496)}$	max.
Abscissa to top (kinked lead)	$H_1$	$H_1$	$\frac{32.2}{(1.268)}$	max.
Overall width w/lead protrusion (straight lead)		$C_1$	$\frac{55.0}{(2.165)}$	max.
Overall width w/lead protrusion (kinked lead)		$C_1$	$\frac{43.2}{(1.7)}$	max.
Overall width w/o lead protrusion (straight lead)		$C_2$	$\frac{54.0}{(2.126)}$	max.
Overall width w/o lead protrusion (kinked lead)		$C_2$	$\frac{42.5}{(1.673)}$	max.
Lead protrusion	$l_1$	$L_1$	$\frac{1.0}{(.039)}$	max.
Protrusion of cutout	$L$	$L$	$\frac{11}{(.433)}$	max.
Protrusion beyond hold-down tape	$l_2$	$l_2$	Not specified	
Sprocket hole pitch	$P_0$	$P_0$	$\frac{12.7}{(0.5)}$	$\frac{\pm 0.3}{(\pm .012)}$
Pitch tolerance			20 consecutive	$\frac{\pm 1}{(\pm .039)}$
Device pitch: MF-R005–MF-R160, MF-R/90, MF-RX110/72–MF-RX185/72			$\frac{12.7}{(0.5)}$	$\frac{\pm 0.3}{(\pm .012)}$
Device pitch: MF-R185–MF-R400, MF-RX110–MF-RX375 MF-R/600, MF-RX250/72–MF-RX375/72			$\frac{25.4}{(1.0)}$	$\frac{\pm 0.6}{(\pm .024)}$
Tape thickness	$t$	$t$	$\frac{0.9}{(.035)}$	max.
Tape thickness with splice: MF-R010–MF-R160, MF-RX110/72–MF-RX185/72		$t_1$	$\frac{1.5}{(.059)}$	max.
Tape thickness with splice: MF-R250–MF-R1100, MF-RX110–MF-RX375, MF-R/90, MF-RX250/72–MF-RX375/72		$t_1$	$\frac{2.3}{(.091)}$	max.
Splice sprocket hole alignment			0	$\frac{\pm 0.3}{(\pm .012)}$
Body lateral deviation	$\Delta_h$	$\Delta_h$	0	$\frac{\pm 1.0}{(\pm .039)}$
Body tape plane deviation	$\Delta_p$	$\Delta_p$	0	$\frac{\pm 1.3}{(\pm .051)}$

DIMENSIONS:  $\frac{\text{MM}}{\text{(INCHES)}}$

Specifications are subject to change without notice.

The device characteristics and parameters in this data sheet can and do vary in different applications and actual device performance may vary over time. Users should verify actual device performance in their specific applications.

# MF-R, MF-R/90, MF-R/600, MF-RX, & MF-RX/72 Series Tape and Reel Specifications

# BOURNS®

Dimension Description	IEC Mark	EIA Mark	Dimensions	
			Dimensions	Tolerance
Lead spacing: MF-R, MF-R/90, MF-R/600, MF-RX, MF-RX/72	<i>F</i>	<i>F</i>	$\frac{5.08}{(0.2)}$	$\frac{\pm 0.2}{(\pm 0.008)}$
Reel width	<i>w</i>	<i>W<sub>2</sub></i>	$\frac{56.0}{(2.205)}$	max.
Reel diameter	<i>d</i>	<i>a</i>	$\frac{370.0}{(14.57)}$	max.
Space between flanges less device	<i>W<sub>1</sub></i>	<i>h</i>	$\frac{4.75}{(.187)}$	$\frac{\pm 3.25}{(\pm .128)}$
Arbor hole diameter	<i>f</i>	<i>c</i>	$\frac{26.0}{(1.024)}$	$\frac{\pm 12.0}{(\pm .472)}$
Core diameter: MF-R, MF-RX, MF-R/90	<i>h</i>	<i>n</i>	$\frac{80}{(3.15)}$	max.
Core diameter: MF-R/600	<i>h</i>	<i>n</i>	$\frac{91}{(3.58)}$	max.
Box: MF-R, MF-RX, MF-R/90			$\frac{62}{(2.44)}$ $\frac{355}{(14.0)}$ $\frac{345}{(13.6)}$	nom.
Box: MF-R/600			$\frac{64}{(2.52)}$ $\frac{372}{(14.6)}$ $\frac{362}{(14.25)}$	max.
Consecutive missing places: MF-R, MF-RX, MF-R/90			3	max.
Consecutive missing places: MF-R/600			none	
Empty places per reel: MF-R, MF-RX, MF-R/90			Not specified	
Empty places per reel: MF-R/600			0.1 %	

**Taped Component Dimensions - Figure 1**

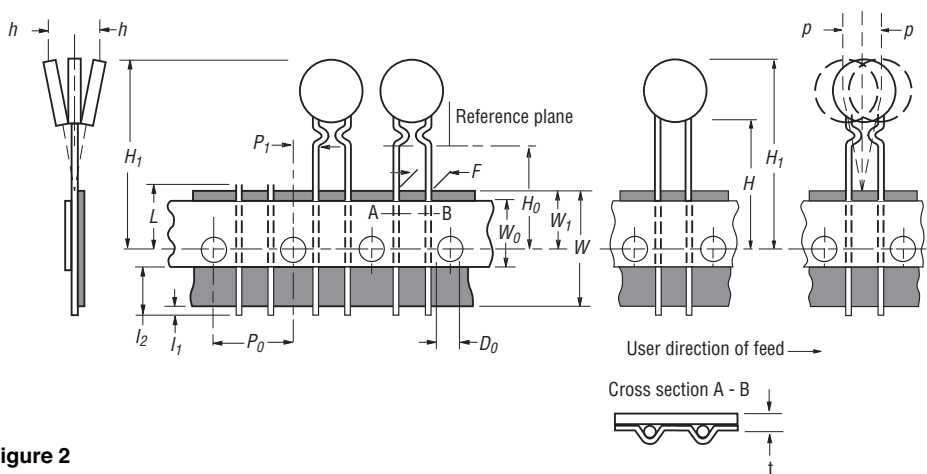

**Reel Dimensions - Figure 2**

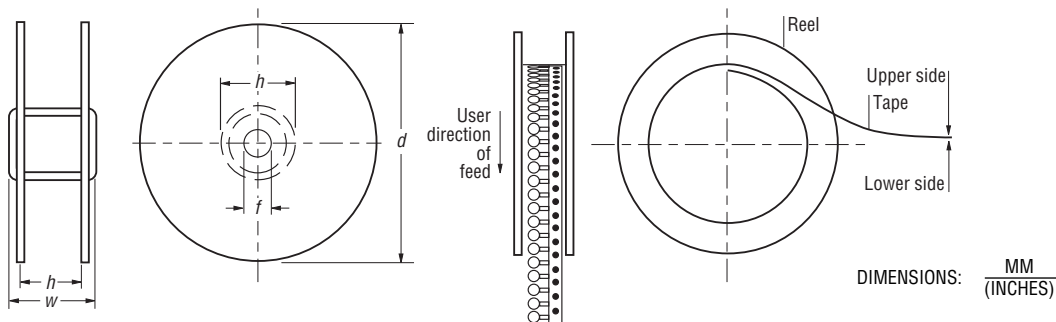

Specifications are subject to change without notice.  
The device characteristics and parameters in this data sheet can and do vary in different applications and actual device performance may vary over time.  
Users should verify actual device performance in their specific applications.