



MADE IN UK

CROMPTON INSTRUMENTS INTEGRA 1222 DIGITAL METERING SYSTEM

The Crompton Instruments INTEGRA 1222 digital metering system (dms) from TE Connectivity enables cost effective solution for the measurement and display of all electrical parameters including total harmonic distortion (THD) and individual, up to the 63rd harmonic.

Display

High definition screen features programmable backlight for high contrast visibility in low light and direct sunlight applications. The light can be programmed to automatically dim after set period of time for energy saving.

New "petal" array icons shows the percentage of full scale power of the measured system and the instantaneous PF measurement gives clear PF indication. Total power consumption is displayed on the screen at all times.

Q2C Wiring Solution

INTEGRA 1222 dms and the 3-in-1 current transformers feature Q2C wiring solution for simple yet fast installation utilising plug and socket connections and pre-cut wiring looms, which allow to reduce assembly time and connection errors. IN-OUT voltage connections reduce wiring and installation time.

Communication

Modbus RTU (RS485) available on all models. Two pulsed outputs available on self powered only.

Enclosure and System

The DIN 96 panel mounted enclosure includes integral panel mounting clips for quick and easy fitting and to suit user requirements, the range includes single-phase, three-phase three-wire and three-phase four-wire capability, all selectable at the point of installation.

Features

- DIN 96 enclosure
- Backlit LCD screen
- Voltage IN-OUT connections
- CT current measurement 5A/1A
- Plug and socket connections
- Programmable VT, CT ratios
- Accuracy to 0.5S%
- Internal product health check.
- Individual harmonics to 63rd
- Non-volatile memory 1MB

Applications

- Commercial Buildings Disclosures
- Nabers
- National Construction Code (NCC)
- Greenstar Energy Management

Approvals

- IEC BS EN 61010-1:2010
- BS EN 61326-1:2013
- BS EN 62052-31:2016
- IEC 62053-22 Class 0.5S
- IEC 62053-24 Class 0.5S

INTEGRA 1222 DIGITAL METERING SYSTEM

Dimensions

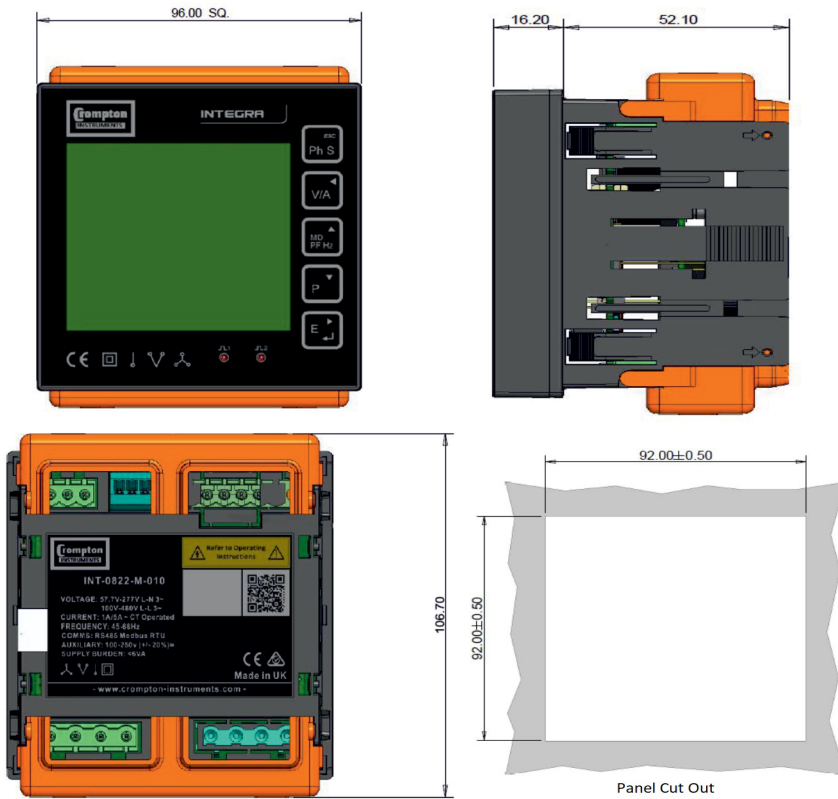

Displayed Parameters

- Voltage per phase L-N, L-L
- Current per phase and Max Demand
- Power Factor – per phase and system
- Total Harmonic Distortion – Voltage and Current per phase
- Neutral current
- Frequency system
- Phase Sequence
- Active Power (P) per phase, total and Max Demand
- Reactive Power (Q) per phase, total and Max Demand
- Apparent Power (S) per phase, total and Max Demand
- Energy – Active and Reactive Importing and Total
- Energy – Active and Reactive Exporting and Total

Auxiliary and Self Powered Wiring Diagrams

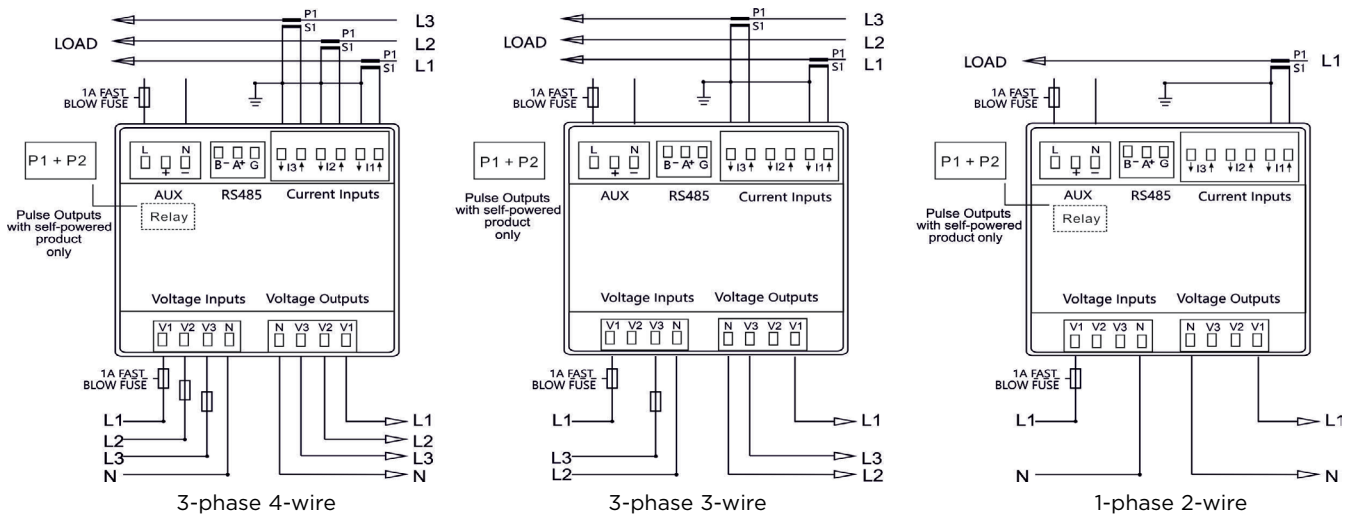

Product Codes

Description	Part number
INTEGRA 1222 multifunction panel meter LCD Display Input 480 V L-L 2 pulsed outputs, Modbus RS485 Self powered	INT-1222-S-010
INTEGRA 1222 multifunction panel meter LCD Display Input 480 V L-L Modbus RS485 Auxiliary powered	INT-1222-M-010

Specifications

Input	
Nominal input voltage (Self Powered)	100 - 277 V AC L-N (173-480 V L-L) 576 V L-L MAX
Nominal input voltage (Auxiliary Powered)	57.7 - 277 V AC L-N (100-480 V L-L) 576 V L-L MAX
Max. continuous input overload voltage	120% of nominal
Max. short duration input voltage	2 x nominal voltage for 1 second
Nominal input voltage burden	< 0.2 VA per phase
Nominal input current	1A AC or 5A AC
Nom. input current burden	< 0.1 VA
Max. continuous input overload current	120% of nominal
Max. short duration input current (300 msec)	20 x nominal current for 1 second
Power Supply (Auxiliary model only)	
Nominal Supply	100 - 250V AC DC +/-20%
Supply burden	<6 VA
Accuracy	
Voltage (V)	+/- 0.5S% of range maximum
Current (A)	+/- 0.5S% of range maximum
Frequency (Hz)	+/- 0.2% of mid-frequency
Power factor (PF)	+/- 0.6% to IEC 62053-22
Active power (W)	+/- 0.5S% of reading
Reactive power (VAr)	+/- 0.5S% of reading
Apparent power (VA)	+/- 0.5S% of reading
Apparant energy (kVAh)	+/- 0.5S% of reading
Active energy (kWh)	+/- 0.5S% of reading to IEC 62053-22
Reactive energy (kVArh)	+/- 0.5S% of reading to IEC 62053-24
THD	2% to 63rd harmonic
Measured Range	
Voltage (V)	5 - 120% of nominal (Min 100 V - self powered)
Current (A)	5 - 120% of nominal
Frequency (Hz)	44 - 66 Hz
Power (W, VAr, VA)	5 - 144% of nominal (bi-directional)
Energy	8 digit, upto 9999999.9 MWh
Power factor	4 quadrant
THD	0 - 40% upto 63rd harmonic
Environment	
Operating temperature	-25°C to +70°C
Storage temperature	-40°C to +80°C
Relative humidity	0 to 95%, non-condensing
Shock	30 g in 3 planes
Vibration	10 Hz to 50 Hz, IEC 60068-2-6, 2 g
Surge voltage	4 kV (IEC 61000-4-5)
Impulse voltage	6 kV (IEC 60060-1)
Electromagnetic immunity	80 MHz - 2 GHz at 10 V/m IEC 61000-4-3
Electrostatic discharge	15 kV (IEC 61000-4-2)
Altitude	3000 m
Warm-up	1 minute
Outputs	
Pulsed output relay (self powered only)	Opto-coupled, potential-free SPST-NO contact
Contact rating current	50 mA at 250 V AC 27 mA at 70 V DC
Contact rating voltage	5-27 V DC
Pulse width	60 / 100 / 200 ms
Pulse rate	0.001/0.01/0.1/1/ 0/100/1000 kWh/kVArh
Pulsed output relay (non-configurable)	2400IMP/kWh
Communications	
Type	Modbus RTU (RS485)
Address	1 to 247
Enclosure	
Enclosure style	DIN 96 panel mount
Dimensions	96x96x62 mm
Panel cut-out	92x92 mm
Panel thickness	1-5 mm
Protection rating	Front IP54, Rear IP30, IP64 (with additional kit)
Material	UL 94-VO
Weight	340 g
Cable size	0.05 mm ² - 2.5 mm ² stranded wire
Terminals	Voltage and Current : Shrouded screw clamp
Display characters	6.2 mm

Parameters

Button	Scr	Parameter
	1	Watts L1 Volts L1 Current L1 Active Energy L1
	2	Watts L2 Volts L2 Current L2 Active Energy L2
	3	Watts L3 Volts L3 Current L3 Active Energy L3
	4	Watts L1 Volts L1 Current L1 Reactive Energy L1
	5	Watts L2 Volts L2 Current L2 Reactive Energy L2
	6	Watts L3 Volts L3 Current L3 Reactive Energy L3
	1	L-N Volts L1, L2, L3
	2	L-L Volts L1, L2, L3
	3	Current L1, L2, L3, N
	4	V-THD% per line
	5	A-THD% per line
	6	Phase Sequence V&I
	1	PF and System Freq
	2	PF per phase
	3	Max Current Demand per phase
	4	System Max demand P, Q, S.
	1	Active Power (P) L1, L2, L3
	2	Reactive Power (Q) L1, L2, L3
	3	Apparent Power (S) L1, L2, L3
	4	System Powers P,Q,S
	1	Imp Active Energy Exp Active Energy
	2	Imp Reactive Energy Exp Reactive Energy
	3	Total Active Energy Total Reactive Energy

Q2C WIRING SOLUTION

Ensures error free installation and reduces wiring time by 80%.

With the Q2C wiring solution, you can quickly and easily connect the INTEGRA 1222 Digital Metering System and 3-in-1 current transformers.

Key Benefits

- A complete wiring solution with integral connectors and earthing
- Screwless terminal connections, vibration proof and maintenance free
- Reduced installation time
- Eliminates potential cost of errors in electrical connections or programming
- Tidy solution for cable management

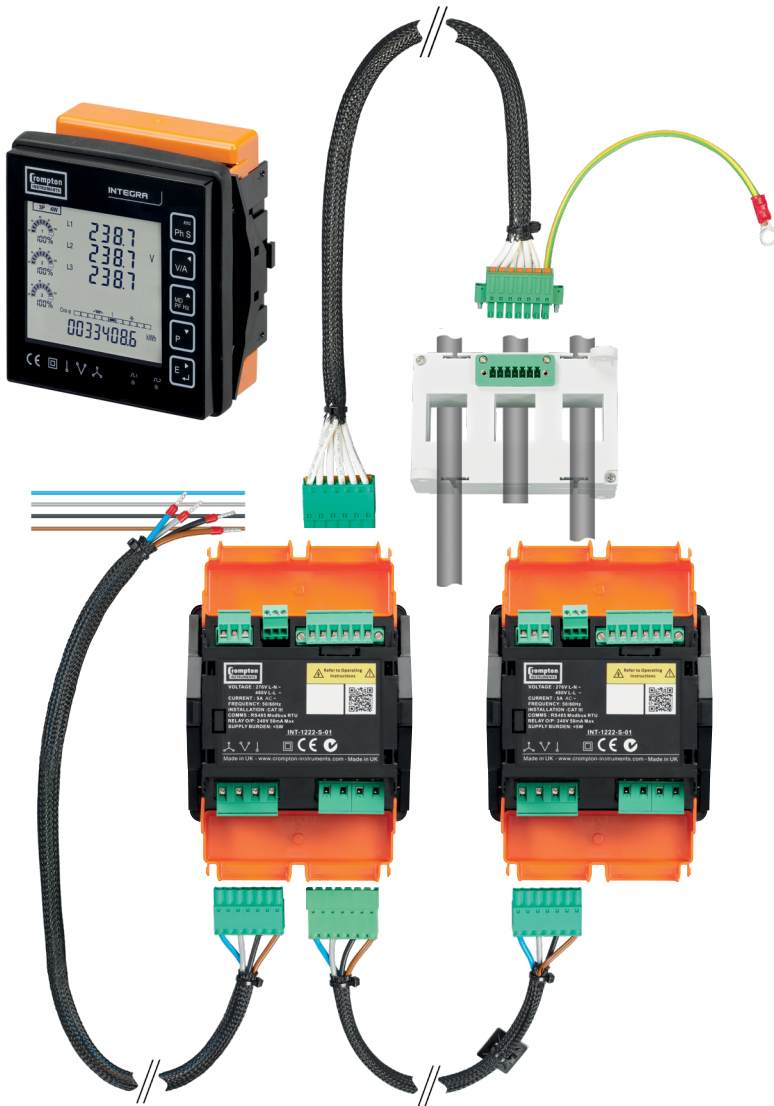

Voltage Meter to Meter Loom

The meter to meter loom connects the voltage for upto 32 meters using high quality LSZH cable fitted with suitable plugs and socket for safe and easy voltage connections.



Part Number	Length
Q2C-VMM-0600-01	600 mm
Q2C-VMM-1000-01	1000 mm
Q2C-VMM-1200-01	1200 mm
Q2C-VMM-1500-01	1500 mm
Q2C-VMM-2000-01	2000 mm
Other lengths available	

Voltage Meter to Open Loom

The meter to open loom connects the voltage supply from the fused connections to the meter using high quality LSZH cable fitted with suitable plugs and socket for safe and easy voltage connections.



Part Number	Length
Q2C-VFO-0600-01	600 mm
Q2C-VFO-1000-01	1000 mm
Q2C-VFO-1200-01	1200 mm
Q2C-VFO-1500-01	1500 mm
Other lengths available	

Current to Meter Loom

The current to meter loom connects the current from the current transformer to the current input on the meter using high quality LSZH cable fitted with suitable plugs and socket for safe and easy voltage connections.

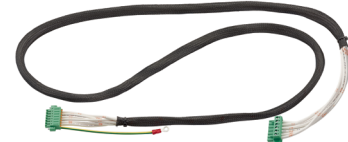

Part Number	Length
Q2C-CTM-0600-01	600 mm
Q2C-CTM-0900-01	900 mm
Q2C-CTM-1200-01	1200 mm
Q2C-CTM-1500-01	1500 mm
Q2C-CTM-2000-01	2000 mm
Q2C-CTM-2500-01	2500 mm
Other lengths available	

Current to Open Loom

The current to open loom connects the any current transformer to the current inputs on the meters using high quality LSZH cable fitted with suitable plugs and socket for safe and easy voltage connections.



Part Number	Length
Q2C-CMO-0600-01	600 mm
Q2C-CMO-0900-01	900 mm
Q2C-CMO-1200-01	1200 mm
Q2C-CMO-1500-01	1500 mm
Q2C-CMO-2000-01	2000 mm
Q2C-CMO-2500-01	2500 mm
Other lengths available	

Q2C 3-IN-1 CURRENT TRANSFORMERS

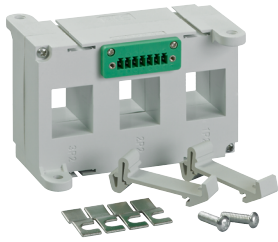

A range of 3-in-1 current transformers to use with or without the Q2C wiring solution. The 3-in-1 current transformers combine three traditional current transformers in one moulded case with a connector for simple and easy installation.

QC3N1-25

76 mm wide x 60 mm deep x 68 mm high

Part number	Ratio	Burden VA against class index			Aperture (mm)
		Class 0.5	Class 1	Class 3	
QC3N1-25-60/5	60/5	-	1	2	3 @ 15x25
QC3N1-25-100/5	100/5	-	1.5	2.5	3 @ 15x25
QC3N1-25-125/5	125/5	-	1.5	2.5	3 @ 15x25
QC3N1-25-160/5	160/5	1.5	1.5	2.5	3 @ 15x25

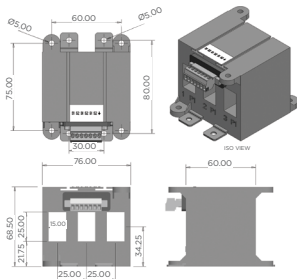

QC3N1-35

105 mm wide x 38 mm deep x 68.5 mm high

Part number	Ratio	Burden VA against class index			Aperture (mm)
		Class 0.5	Class 1	Class 3	
QC3N1-35-100/5	100/5	-	1.5	2	3 @ 21x25
QC3N1-35-125/5	125/5	-	1.5	2.5	3 @ 21x25
QC3N1-35-160/5	160/5	1.5	1.5	2.5	3 @ 21x25
QC3N1-35-250/5	250/5	1.5	1.5	2.5	3 @ 21x25

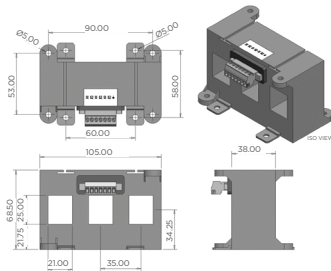

QC3N1-45

142 mm wide x 39 mm deep x 86 mm high

Part number	Ratio	Burden VA against class index			Aperture (mm)
		Class 0.5	Class 1	Class 3	
QC3N1-45-250/5	250/5	-	2.5VA	-	3 @ 32x27
QC3N1-45-400/5	400/5	-	2.5VA	-	3 @ 32x27
QC3N1-45-630/5	630/5	2.5VA	5VA	-	3 @ 32x27

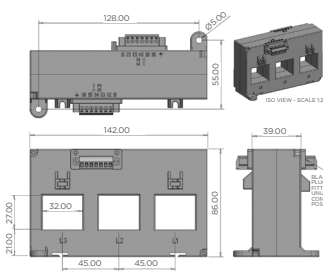

QC3N1-70

212 mm wide x 39 mm deep x 100 mm high

Part number	Ratio	Burden VA against class index			Aperture (mm)
		Class 0.5	Class 1	Class 3	
QC3N1-70-400/5	400/5	-	2.5VA	-	3 @ 52x40
QC3N1-70-630/5	630/5	2.5VA	2.5VA	-	3 @ 52x40
QC3N1-70-800/5	800/5	2.5VA	5VA	-	3 @ 52x40

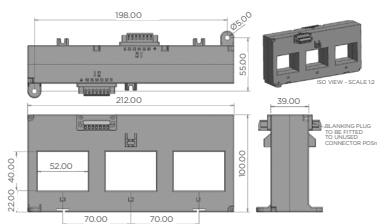

3-IN-1 CURRENT TRANSFORMERS

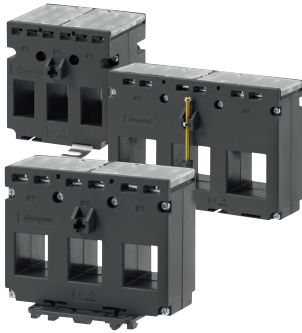

A range of 3-in-1 current transformers combine three traditional current transformers in one moulded case. 3-in-1 current transformers can be directly installed next to a three-phase moulded case circuit breaker, thus saving installation time where fitting three standard individual current transformers would be required. The M3N1 range of current transformers offers primary currents between 60-630A with 5A secondaries with up to Class 0.5 accuracy performance.

M3N1-25

Case size: 75 mm wide x 60 mm deep x 80 mm high

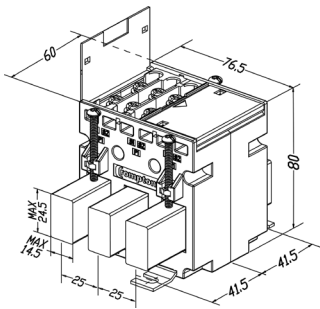

Part number	Ratio	Burden VA against class index			Aperture (mm)
		Class 0.5	Class 1	Class 3	
M3N1-25-60/5	60/5	-	1	2	3 @ 15x25
M3N1-25-100/5	100/5	-	1.5	2.5	3 @ 15x25
M3N1-25-125/5	125/5	-	1.5	2.5	3 @ 15x25
M3N1-25-160/5	160/5	1.5	1.5	2.5	3 @ 15x25

M3N1-35

Case size: 105 mm wide x 38 mm deep x 80 mm high

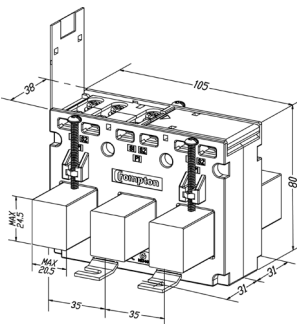

Part number	Ratio	Burden VA against class index			Aperture (mm)
		Class 0.5	Class 1	Class 3	
M3N1-35-100/5	100/5	-	1	2	3 @ 21x25
M3N1-35-125/5	125/5	-	1.5	2.5	3 @ 21x25
M3N1-35-150/5	150/5	-	1.5	2.5	3 @ 21x25
M3N1-35-160/5	160/5	1.5	1.5	2.5	3 @ 21x25
M3N1-35-200/5	200/5	1.5	1.5	2.5	3 @ 21x25
M3N1-35-250/5	250/5	1.5	1.5	2.5	3 @ 21x25

M3N1-45

Case size: 141 mm wide x 38 mm deep x 95 mm high

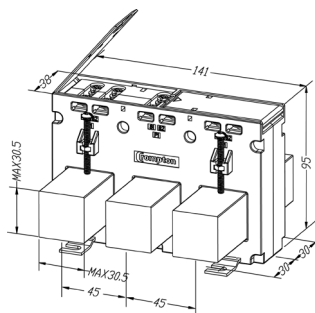

Part number	Ratio	Burden VA against class index			Aperture (mm)
		Class 0.5	Class 1	Class 3	
M3N1-45-250/5	250/5	1.5	1.5	2.5	3 @ 31x31
M3N1-45-300/5	300/5	2.5	2.5	3.75	3 @ 31x31
M3N1-45-400/5	400/5	2.5	2.5	3.75	3 @ 31x31
M3N1-45-500/5	500/5	2.5	2.5	3.75	3 @ 31x31
M3N1-45-600/5	600/5	2.5	2.5	3.75	3 @ 31x31
M3N1-45-630/5	630/5	2.5	2.5	3.75	3 @ 31x31

CURRENT TRANSFORMERS RANGE

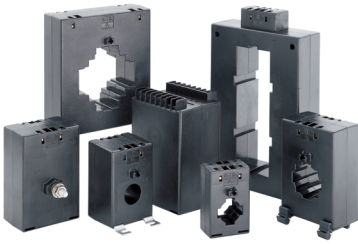

Ebony Current Transformers

The range of Crompton Instruments Ebony current transformers offers wide system current ratings, apertures, busbar and case sizes to suit every application. Manufactured to meet EN60044 the range benefits include ratio rating from 1/5 to 6000/5, accuracy up to Class 0.5, integral terminal cover for safety and multiple mounting options.

Supplied with metal feet. DIN rail clips and busbar mounting as standard.

For use with the CTO range of wiring looms.



MR series Current Transformers

MR transformers are used to accurately measure high alternating primary currents, converting the primary current into a proportional secondary current as required for measurement and instrumentation. They are available in 5 amp or 1 amp secondary versions.

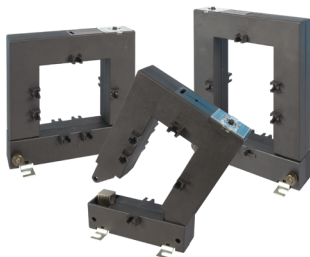

Split Core Current Transformers

A range of split core current transformers that offers a cost effective and efficient method by which the current can be measured without the need to break the conductor, thereby reducing installation and commissioning time.



Miniature Split Core Current Transformers

A range of miniature split core current transformers that offers a cost effective and efficient method by which the current can be measured without the need to break the conductor, each current transformer is supplied with colour coded leads of up to 3 meters for connection to the monitoring device. The MSC range of current transformers offers primary currents between 60-500A with 1 or 5A secondaries with class 1 accuracy performance. (Class 3 for 60-80A range).

For full range and part numbers visit
Crompton-instruments.com

About TE Connectivity

TE Connectivity Ltd. (NYSE: TEL) TE Connectivity is a \$12 billion global technology leader. Our commitment to innovation enables advancements in transportation, industrial applications, medical technology, energy, data communications, and the home. TE's unmatched breadth of connectivity and sensor solutions, proven in the harshest of environments, helps build a safer, greener, smarter and more connected world. With 75,000 people – including more than 7,000 engineers – working alongside customers in nearly 150 countries, we help ensure that EVERY CONNECTION COUNTS.

WHEREVER ELECTRICITY FLOWS, YOU'LL FIND TE ENERGY



crompton-instruments.com

For email or phone, go to:

crompton-instruments.com

FOR MORE INFORMATION: TE Technical Support Centres

UK +44 1376 509 401
USA: +1 800 327 6996
Australia +61 1300 656 090
Singapore +65 6590 5151
Hong Kong: +852 2738 8193



crompton-instruments.com

© 2018 TE Connectivity Ltd. All Rights Reserved. EPP-2882-02/19.

TE, TE Connectivity, the TE connectivity (logo) and Integra are trademarks of the TE Connectivity Ltd. family of companies. Crompton is a trademark of Crompton Parkinson and is used under a licence. Other logos, product and company names mentioned herein may be trademarks of their respective owners. While TE has made every reasonable effort to ensure the accuracy of the information in this brochure, TE does not guarantee that it is error-free, nor does TE make any other representation, warranty or guarantee that the information is accurate, correct, reliable or current. TE reserves the right to make any adjustments to the information contained herein at any time without notice. TE expressly disclaims all implied warranties regarding the information contained herein, including, but not limited to, any implied warranties of merchantability or fitness for a particular purpose. The dimensions in this brochure are for reference purposes only and are subject to change without notice. Specifications are subject to change without notice. Consult TE for the latest dimensions and design specifications.