

DO NOT SCALE DRAWING

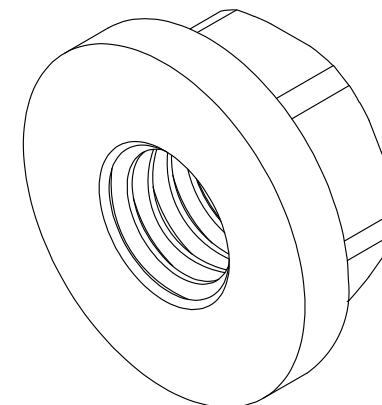
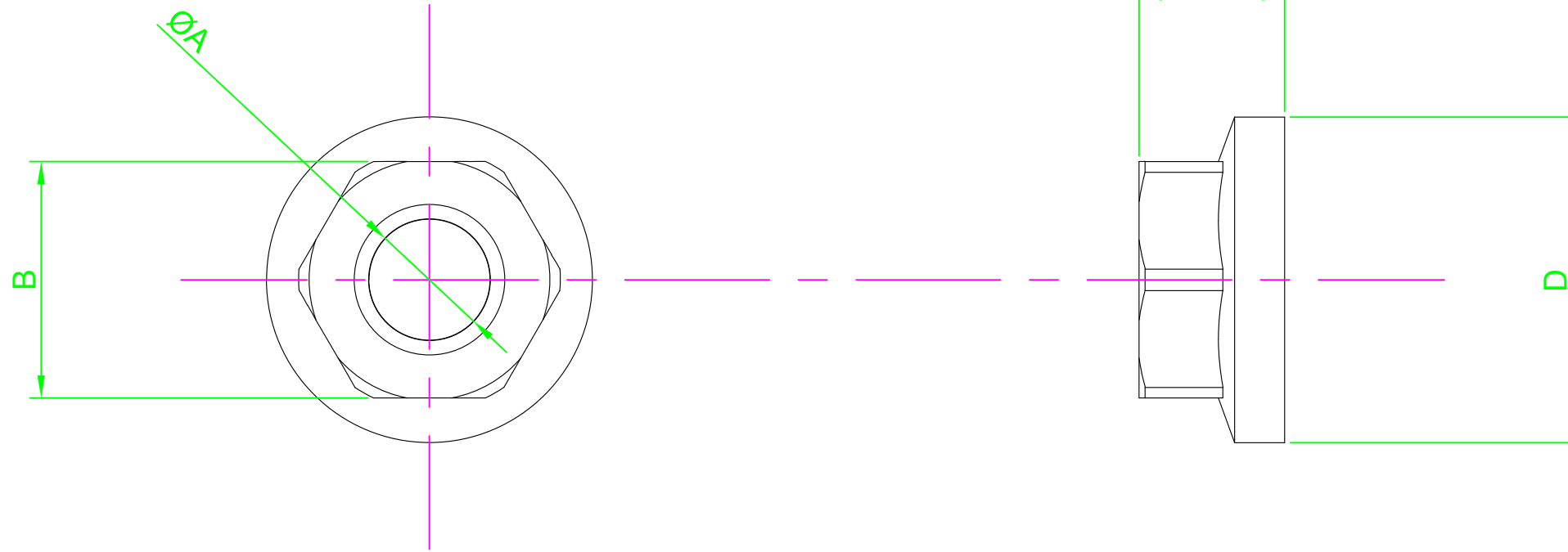

REVISION	
A	INITIAL DRAWING 24.9.15

Part Number	ØA	B Nom	C Max	D Max
M5 - FNST- Z100	M5-0.8	8	5	11.8
M6 - FNST- Z100	M6-1.0	10	6	14.2
M8 - FNST- Z100	M8-1.25	13	8	17.9

NOTES:



DESIGN RIGHT. TR FASTENINGS LTD, 2003
 UNDER NO CIRCUMSTANCES MUST THIS
 DRAWING BE COPIED OR DISCLOSED
 WITHOUT FIRST OBTAINING WRITTEN
 AUTHORITY.

UNLESS OTHERWISE SPECIFIED:
 DIMENSIONS ARE IN MM (MILLIMETERS).
 SURFACE FINISH:
 TOLERANCES: DIN 6923

NAME	DATE
DRAWN Darryl Wilson	24.09.15
CHK'D	
APPVD	

MATERIAL:
 Steel

HEAT TREATMENT:

TITLE:
 Hex Flange Nut DIN 6923

CUSTOMER PART NUMBER:
 N/A

FINISH:
 TC1 - Commercial ZInC/Clear Trivalent

DRAWING NUMBER:
 TR32FNST-

A4

PROJECTION

