

Face milling cutters, 45°

For milling cutter indexable inserts SEET 1204, SEEW 1204

ATORN®

Application

Universal use in all materials.

Version

- Wear-resistant, nickel-plated version
- With robust support design
- Extremely soft cut
- Variable pitch for smooth running
- Clamping screw tightening torque (indexable insert) M5 = 8 Nm

Art. No.	16024 126
Min. cutting edge diameter	125 mm
Max. cutting edge diameter	138 mm
Length	63 mm
Bore diameter	40 mm
max. ap	6 mm
Number of cutting edges	9 PCS

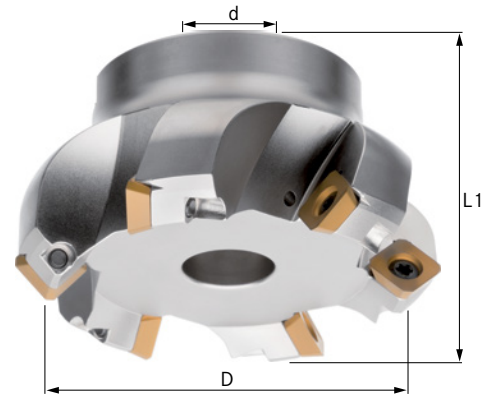

EAN-Code

4050293320794

